



**MODELS  
810/815**

Progressing  
Cavity Pumps



## Features:

- 230 Volt 1 phase
- 1.25" NPT discharge
- Tri-slice® cutter design provides superior grinding with sharper cutting edges
- Cutting plate decreases solids to less than 1/8"
- Buna-N hydraulic stator
- 1750 RPM
- Durable, epoxy coated cast iron construction
- Oil filled motor
- Carbon ceramic shaft seal with superior protection from debris
- Buna-N elastomers
- 304 stainless steel hardware
- NSF/ANSI 46
- Integral relief valve for added pump and motor protection
- 100% computerized water tested

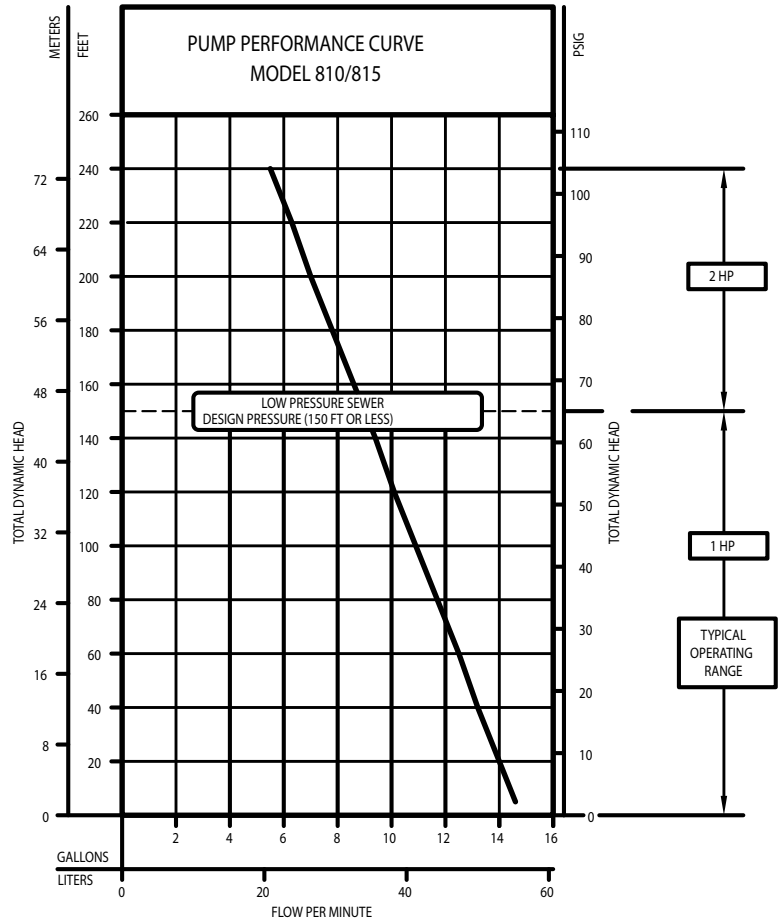
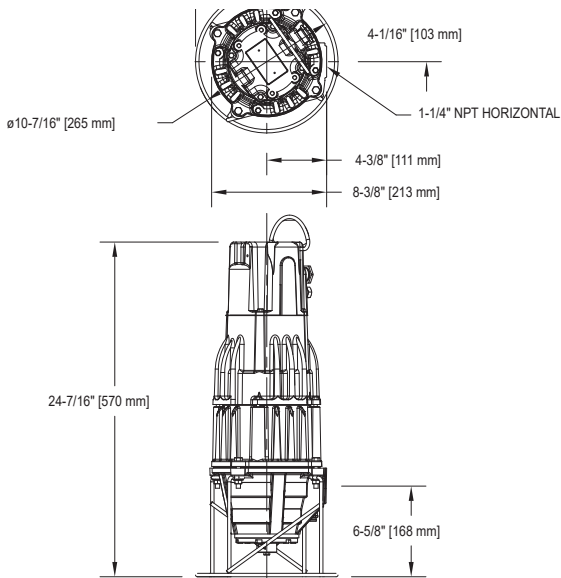

SK2533

018330

 Certified to CSA Standard C22.2 No. 108.

 NSF / ANSI 46

 POWDER COATED

 Submersible Wastewater Pump Association MEMBER

FM3451  
0624  
Supersedes  
0224