

Installer Friendly Series®

SJE Rhombus® Type IFS w/C-Level™ Sensor

Installation Instructions and Operation/Troubleshooting Manual



This control panel must be installed and serviced by a licensed electrician in accordance with the National Electric Code NFPA-70, state and local electrical codes. All conduit running from the sump or tank to the control panel must be sealed with conduit sealant to prevent moisture or gases from entering the panel. **NEMA 4X enclosures are for indoor or outdoor use**, primarily to provide a degree of protection against corrosion, windblown dust and rain, splashing water and hose-directed water. **Cable connectors must be liquid-tight in NEMA 4X enclosures.**

The C-Level sensor is suitable for use in sewage applications. Do NOT use in potable water.

Installation

Installer Friendly Series® (IFS) control panels are designed to control pump(s). The controller records number of pump cycles, elapsed run time, alarm counts, and signal error counts.

Mounting the Control Panel

Note: The control panel should not be mounted in a location that may be subject to submersion.

1. Determine mounting location for panel. If distance exceeds the length of either the sensor or float cables or the pump power cables, splicing will be required. **Note:** Please refer to C-Level™ Sensor installation instructions for splicing instructions. Maximum total cable length is 300 feet. For outdoor or wet installation, we recommend the use of an SJE Rhombus® liquid-tight junction box with liquid-tight connectors to make required connections. **You must use conduit sealant to prevent moisture or gases from entering the panel.**

2. Mount control panel with mounting devices furnished.
3. Determine conduit entrance locations on control panel. Check local codes and schematic for the number of power circuits required. **(Sensor cable requires separate conduit from power and pump cables.)**

Note: Be sure the proper power supply voltage, amperage, and phase meet the requirements of the pump motor(s) being installed. If in doubt, see the pump identification plate for voltage/phase requirements.

4. Drill proper size holes for type of connectors being used.

Note: If using conduit, be sure that it is of adequate size to pull the pump cable(s) through.

5. Attach cable connectors and/or conduit connectors to control panel.

**FOR INSTALLATION REQUIRING A SPLICE, FOLLOW STEPS 6-10;
FOR INSTALLATION WITHOUT A SPLICE, GO TO STEP 11.**

Warranty void if panel is modified.

Call factory with servicing questions:

1-800-RHOMBUS
(1-800-746-6287)

Manufactured by:



SJE RHOMBUS®

Technical Support: +1 800-746-6287

techsupport@sjerhombus.com

www.sjerhombus.com

Technical Support Hours:

Monday - Friday, 7 A.M. to 6 P.M. Central Time

PN 1036677E 07/23
© 2020 SJE, Inc. All Rights Reserved.
SJE RHOMBUS is a trademark of SJE, Inc.

Installation Instructions

6. Determine location for mounting junction box according to local code requirements. **Do not** mount the junction box inside the sump or basin.
7. Mount junction box to proper support.
8. Run conduit to junction box. Drill proper size holes for the type of conduit used.
9. Identify and label each wire before pulling through conduit into control panel and junction box. Make wire splice connections at junction box.
10. Firmly tighten all fittings on junction box.
11. If a junction box is not required, pull cables through conduit into control panel.
12. Connect pump wires per wiring diagram or schematic, and sensor or float wires to the proper terminals as shown on the schematic.
13. Connect pump, control, and alarm incoming power conductors to proper position on terminals. See schematic for terminal connections.

VERIFY CORRECT OPERATION OF CONTROL PANEL AFTER INSTALLATION IS COMPLETE.

Installation of C-Level Sensor and Floats

WARNING: Verify C-Level™ and IFS panel are matched with CL40 or CL100. Using wrong sensor with panel will cause settings to be incorrect.

CAUTION: If control switch cables are not wired and mounted in the correct order, the pump system will not function properly. Sensor and float cables need to run in separate conduit from pump and power lines.

Industry practices suggest that a secondary device, such as a float switch, be used for redundant activation of the high level alarm and pump shut off.

WARNING: Turn off all power before installing pump wires in pump chamber. Failure to do so could result in serious or fatal electrical shock.

NOTE: The C-Level™ sensor operates between 0 and 39.9 inches of water pressure for the CL40 or between 0 and 99.9 inches of water pressure for the CL100. The C-Level™ sensor reads 0 inches at the approximate point shown in **Figure 2**. As the liquid level rises, the IFS display shows depth of liquid from the zero point. The minimum set point for the stop (demand) or redundant off (timed dose) level is 4 inches (measured from 0) see **Figure 2**.

The maximum set point allowed is 39 inches (measured from 0) for the CL40 or 99 inches (measured from 0) for the CL100. Operating temperature range is 32°F (0°C) to 120°F (50°C).

1. Determine the nominal operating levels for the configuration, as illustrated in **Figure 3 or 4**.
2. Position C-Level sensor at appropriate location on pipe and secure sensor as shown in **Figure 2** using a hose clamp.

WARNING: Do not support the C-Level sensor by the cable. Position the sensor in the tank so that nothing is pushing in the diaphragm.

3. Ensure the vent at the end of the cable is not plugged and in a water tight enclosure.

WARNING: Do **NOT** kink or place vented cable under an extreme clamp. **Doing so will cause sensor to fail.**

4. If optional high water or redundant off floats are used, position and secure as shown in **Figures 1, 3 or 4**. Redundant off float should be located to activate at approximately the zero point for the C-Level per **Figure 3 or 4**.

NOTE: SJE Rhombus® recommends using the optional high water alarm float for added protection against flooding.

5. Tighten all hose clamps using a screw driver. Over tightening may result in damage to the plastic parts.

NOTE: All hose clamp components are made of 18-8 stainless steel material. See your SJE Rhombus® supplier for replacement parts.

6. Functionally test the system by filling the tank and witnessing proper operation.

Installation Instructions

Figure 1

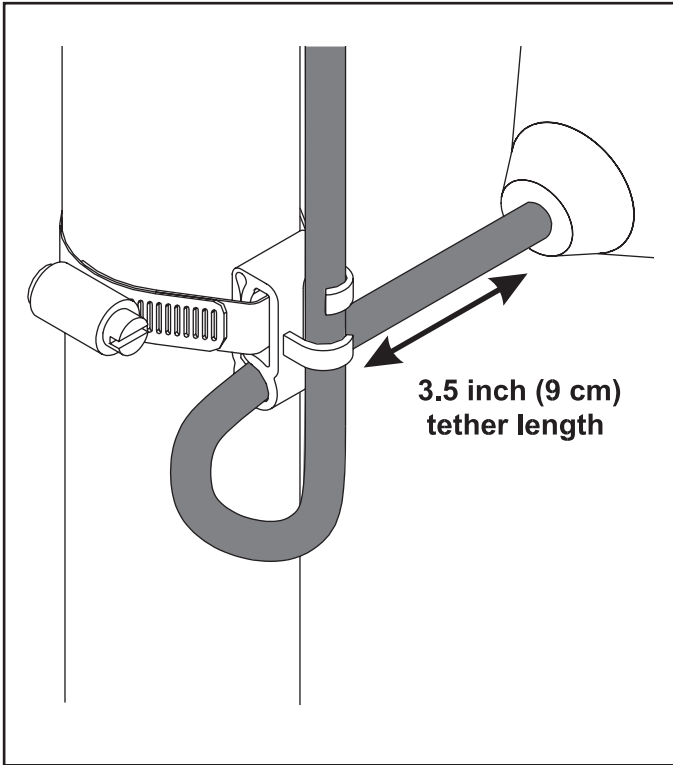

Figure 2

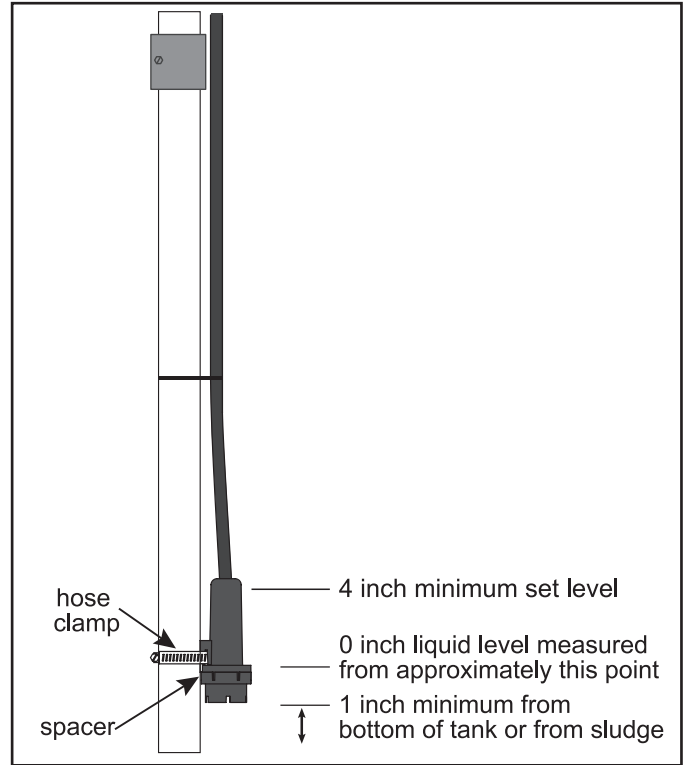

Figure 3 - Timed Dose

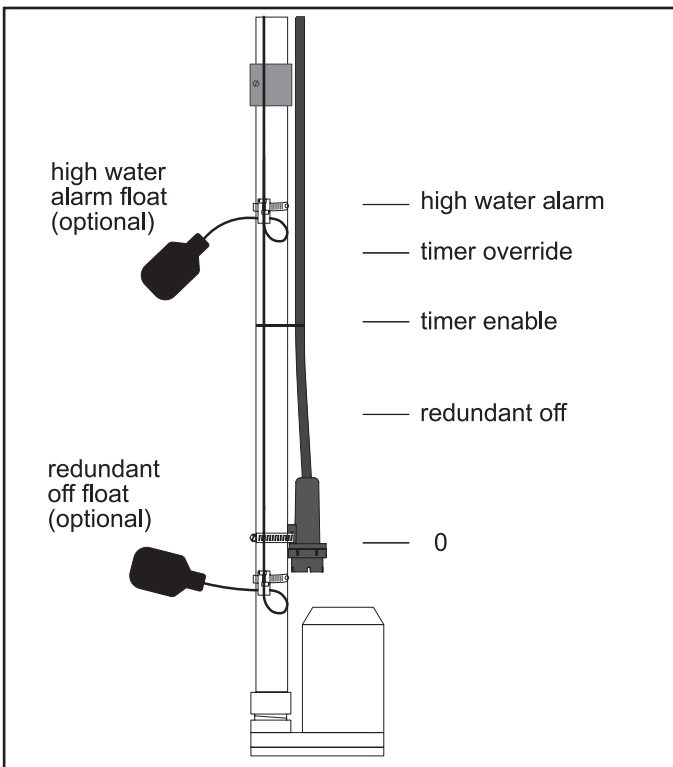
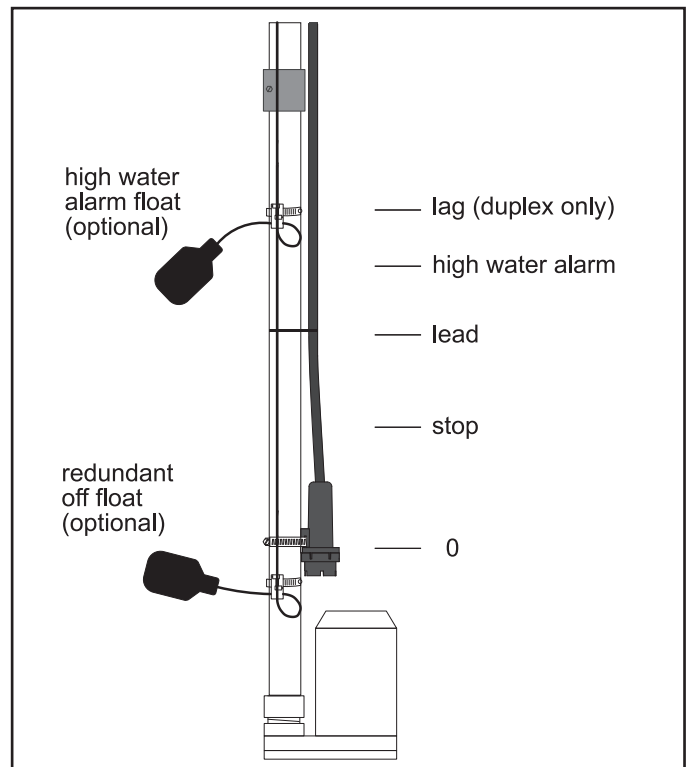

Figure 4 - Demand Dose



Operations

The Installer Friendly Series (IFS) control panel uses the C-Level sensor to continuously monitor and control the liquid level in the tank. An optional high water alarm float and redundant off float can be used to provide additional protection from high or low water conditions.

Hand Operation - The level must be above the stop/redundant off set point to put the panel in HAND operation. To override the stop/redundant off set point, press and hold the HAND button. The pump runs until the HAND button is released. The panel then returns to the AUTO mode. If the level is above the stop/redundant off set point and the panel is placed in the HAND mode, and left in HAND mode, the pump continues to run until the liquid level reaches the stop/redundant off set point. The panel then returns to the AUTO mode.

Off Operation - The panel is in the OFF mode.

Auto Operation - In time dose (t-dose) mode, when the panel is in the AUTO mode, the timer controls pump ON and OFF time as long as the redundant off and timer enable set points are activated. In demand (d-dose), the stop and lead set points control the pump.

Level Indicators - Illuminate if the corresponding set point is triggered.

Green Control and Alarm Power Indicators - (mounted on interior circuit board) Illuminates when control power and alarm power is present. If the control fuse needs replacing the panel sounds an alarm.

LED Display - Used to view and set panel settings and cycle count data. Will turn off after five minutes of non-use.

Viewing Panel Settings and Cycle Data

To view panel settings and cycle data press the **NEXT** button. Each time the **NEXT** button is pressed the display will advance to the next setting or cycle data. Information will be displayed in the following order:

in - Level of the liquid measured from the zero point on the sensor. This will be shown in inches or centimeters depending on the units selected.

t-dOSE or d-dOSE – Identifies if the panel is configured as a time dose or demand dose panel.

Et 1 – Elapsed time meter for pump 1 shown in hh:mm:ss.

CC 1 – Cycle count for pump 1.

AL 1Ctr – Cycle count for Duo Alarm 1 option for single phase models **OR**
Cycle count for Pump 1 Fail for three phase models and single phase models with overloads.

Et 2 – Elapsed time meter for pump 2 shown in hh:mm:ss (duplex only)

CC 2 – Cycle count for pump 2 (duplex only).

AL 2Ctr – Cycle count for Duo Alarm 2 option for single phase models **OR**
Cycle count for Pump 2 Fail for three phase models and single phase models with overloads.

AL-Ctr – Alarm counter which includes high water alarm, float error alarm, and Duo Alarm 1 and 2.

FE-Ct – Float error counter which counts how many times the water level drops below the bottom of the sensor and when the optional redundant off float opens.

tO-Ct – Timer override which counts how many times the liquid level has reached the timer override set point (time dose only).

On – On time currently set for the pump shown in hh:mm:ss (time dose only).

OFF – OFF time currently set for the pump shown in hh:mm:ss (time dose only).

t-OFF or t-On – Display counts down the OFF or On time remaining in the cycle (time dose only).

Operations

Programming Panel Settings

Entering the program mode:

Press and hold the **SET** button for 3 seconds until the "Prog" is displayed. The first parameter that can be set, along with its current value, will then flash on the display. You are now in the program mode.

Exiting the program mode:

At any point in the program mode push and hold the **SET** button for 3 seconds until run is displayed. The display will then return to its normal state.

To change and set a parameter:

NOTE: While setting parameters the following conditions must be met or the display will show (ERROR):

LAg	- level must be above LEAd for Demand Dose
LEAd	- level must be above StOP for Demand Dose
StOP	- level must be 4 inches or higher for Demand Dose
tO	- level must be above tEnBLE for Time Dose
tEnBLE	- level must be above rEdOFF for Time Dose
rEdOFF	- level must be 4 inches or higher for Time Dose.

1. When in the program mode push the NEXT button until the desired parameter is displayed.
2. Push the SET button and the current value of that parameter will be displayed with the first digit flashing.
3. Use the UP button to change the value of the flashing digit. When the desired value of the flashing digit is reached, push the NEXT button to advance to the next digit. Use the UP and NEXT buttons to set the total value of that parameter.
4. When done setting the parameter, push the set button and the parameter will flash along with its new value. If an (ERROR) message is received, check above conditions to ensure all are being met.
5. Push the NEXT button to advance to the next parameter and follow steps 2 – 4 to set the values.

Parameters that can be set:

The parameters that can be set when in the program mode are:

For Time Dose Panels:

On – On time for pump in hh:mm:ss

OFF – Off time for the pump in hh:mm:ss

ALtErn – Sets the alternation of the pumps. Settings are ALt, 2-1 and 1-2. (duplex panels only)

ALAr – High water alarm set point.

tO – Timer override set point

tEnBLE – Timer enable set point

rEdOFF – Redundant off set point.

UnitS – Units of measure can be set in inches (in) or centimeters (c).

For Demand Dose Panels:

ALtErn – Sets the alternation of the pumps. Settings are ALt, 2-1 and 1-2. (duplex panels only)

ALAr – High water alarm set point.

LAg – Lag pump start point. (duplex panels only)

LEAd – Lead pump start point.

StOP – Pump stop set point.

UnitS – Units of measure can be set in inches (in) or centimeters (c).

Operations

Selecting Time Dose or Demand Dose - Panels in the field

To set the panel to either Timed Dose or Demand Dose in the field:

1. Turn the control/alarm power off to the control panel.
2. Turn the pump power off to the control panel.
3. Place a small screwdriver or pen into the slot in the label on the inner door marked "DEMAND DOSE TIMED DOSE".
 - Move the dip switch (up) for demand dose
 - Move the dip switch (down) for Timed dose
4. Turn the control/alarm power on to the control panel. After the display goes blank press the "NEXT" switch.
 - The display will show d-dose for demand dose.
 - The display will show t-dose for timed dose.

WARNING: Changing the dip switch positions will change the operation of the panel.

WARNING: If changing to timed dose, be sure to set the off and on times.

5. Turn on the pump power after all the settings are changed.
6. **WARNING:** Check the panel for correct operation before leaving the site.

Troubleshooting

C-Level Sensor

1. Verify that the vented cable is not kinked or has any holes in it. If either condition exists, the pressure sensor may fail or give inaccurate level readings.
2. Tubing in vented cable is to be unobstructed and in a dry environment. Obstructing the vent will result in an error or inaccurate readings, as it is needed to compensate for barometric pressure changes.
3. The black diaphragm is located on the end of the sensor body. The diaphragm must not be damaged or deformed. A damaged or deformed diaphragm will result in inaccurate level readings.
4. Verify the bottom of the C-Level Sensor is not resting on the bottom of the tank or on any other obstacle.
5. Verify that the electrical cable is not damaged or severed.
6. Verify that the shielding for cable is properly attached to ground.
7. If the panel includes the optional redundant off float, verify that the float is properly wired to the panel.

Fuse

To check the continuity of the fuse, pull the fuse out of the fuse holder. With the ohmmeter on the R X 1 scale, measure resistance. A reading of infinity (high resistance) indicates a blown fuse that must be replaced with a fuse of the same type, voltage, and amp rating.

Alarm Light

With power on, hold the test/normal/silence switch in the "test" position. The alarm light should turn on. If not, replace the light with that of the same type.

Alarm Horn

With power on, hold the test/normal/silence switch in the "test" position. The alarm horn should turn on. If not, replace the horn with that of the same type.

