

# EZ Series® Plugger Post Control Panel

Easy to install control panel provides convenient wiring connection for use with one single phase pump in effluent and sewage installations.

The EZ Series® Plugger Post control panels feature a sleek easy to install panel and mounting post. The panel incorporates a receptacle to accept 120 VAC or 240 VAC pump and piggy-back pump switch.

The post includes an access door and simplex installation kit which allow piggy-back and pump plugs to be easily routed and sealed into the panel. The post can be mounted in the ground directly, over a 4X4, or over conduit.

## PANEL COMPONENTS

1. **Enclosure** measures 10 x 8 x 6 inch (25.40 x 20.30 x 15.2 cm) with removable mounting feet, NEMA 4X rated, ultraviolet stabilized thermoplastic for indoor and outdoor use.
2. **Removable Plate** for easy wiring/installation.
3. **Receptacle** for use with piggy-back pump switch.
4. **Simplex Installation Kit:**
  - 2" **Hub Assembly and Cord Seal** for pump switch, pump, and alarm float.
  - 3/4" **Hub Assembly** for incoming power for pump and alarm wiring (must be sealed to prevent gases and moisture from entering enclosure).
5. **Incoming Power and Indoor Remote Alarm Terminal Block**
6. **Mounting Post.**
7. **Access Door.**
8. **Ground Lug**
9. **Riser Mounting Kit (not shown):**
  - 2" **Hub Assemblies (2)**
  - 2" x 6" **PVC pipe and connecting hardware**
  - **Conduit for routing pump and float from tank riser to post**

**NOTE:** Schematic/Wiring Diagram is located inside the panel.

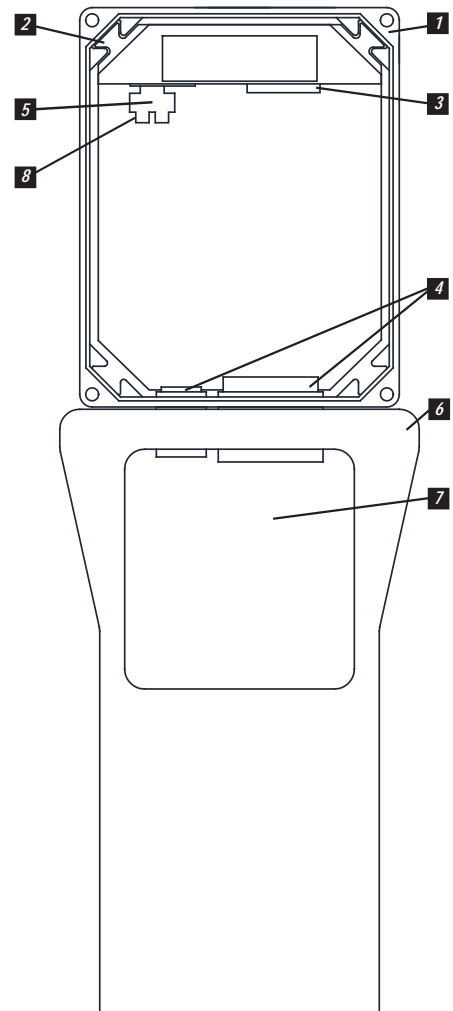

## FEATURES

- 34" mounting post with Simplex Installation Kit
- Entire control system (panel and switches) is UL Listed to meet and/or exceed industry safety standards
- Dual safety certification for the United States and Canada
- Standard package includes alarm float switch
- Complete with step-by-step installation instructions
- Tank Alert® AB Indoor Remote Alarm
- Five-year limited warranty



## OPTIONAL FEATURES

- Elapsed Time Meter (See specific part numbers on reverse page)

**SJE**  
**Rhombus**®

PO Box 1708, Detroit Lakes, MN 56502

1-888-DIAL-SJE • 1-218-847-1317

1-218-847-4617 Fax

email: [customer.service@sjerhombus.com](mailto:customer.service@sjerhombus.com)

[www.sjerhombus.com](http://www.sjerhombus.com) 11

# EZ Series® Plugger Post Control Panel

Easy to install control panel provides convenient wiring connection for use with one single phase pump in effluent and sewage installations.

120 VAC		List Price	Shipping Weight
Part#	Description		
1038954	EZ Series® Plugger 120V with Post, Tank Alert® AB, 15' SJE SignalMaster®	\$511.00	14.00 lbs
1039007	EZ Series® Plugger 120V with Post, Tank Alert® AB, 15' SJE SignalMaster®, Elapsed Time Meter	\$609.00	14.05 lbs

240 VAC		List Price	Shipping Weight
Part#	Description		
1038955	EZ Series® Plugger 240V with Post, Tank Alert® AB, 15' SJE SignalMaster®	\$539.00	14.00 lbs
1039008	EZ Series® Plugger 240V with Post, Tank Alert® AB, 15' SJE SignalMaster®, Elapsed Time Meter	\$634.00	14.05 lbs

## SPECIFICATIONS

**VOLTAGE:** 120 VAC or 240 VAC

**ENCLOSURE** 10 x 8 x 6 inch (25.4 x 20.3 x 15.2 cm)  
NEMA 4X weatherproof thermoplastic with hinged door.

**RECEPTACLE FOR PUMP AND PUMP CIRCUIT** 120V or 240V

**RISER EXTENSION COUPLING AND WASHERS**

**CORD SEAL** Custom engineered to provide liquid tight seal and provide strain relief for pump and float cords.

**ELECTRICAL CONDUIT HUB**



**SJE  
Rhombus®**

[www.sjerhombus.com](http://www.sjerhombus.com)

[customer.service@sjerhombus.com](mailto:customer.service@sjerhombus.com)

**Call or fax your order!**

**1-888-DIAL-SJE (1-888-342-5753) ■ Fax 218-847-4617**

*Product offering and pricing are subject to change without notice.  
Please visit [www.sjerhombus.com](http://www.sjerhombus.com) for the most current information.*

Cat Page PN 1039045C-WEB  
© SJE-Rhombus 12/15