

# Duplex Timed Dosing Control

## SJE-Rhombus® Type DTD

### Installation Instructions and Operation/Troubleshooting Manual



This control panel must be installed and serviced by a licensed electrician in accordance with the National Electric Code NFPA-70, state and local electrical codes.

All conduit running from the sump or tank to the control panel must be sealed with conduit sealant to prevent moisture or gases from entering the panel. **NEMA 4X enclosures are for indoor or outdoor use**, primarily to provide a degree of protection against corrosion, windblown dust and rain, splashing water and hose-directed water. **Cable connectors must be liquid-tight in NEMA 4X enclosures.**

## Installation

Type DTD control panels are designed to operate with two, three or four float systems. The two float system utilizes one float as the low level cutout, and the second as high level alarm. A three float system would add either a redundant off float or a timer override float to the low level cut out and high level alarm floats. A four float system would add both a redundant off float and a timer override float to the low level cutout and high level alarm floats.

**NOTE: Options ordered may affect the number of floats and their functions. Please reference the schematic provided with the control panel for proper installation.**

### Installation of Floats

**CAUTION:** If control switch cables are not wired and mounted in the correct order, the pump system will not function properly.

**WARNING:** Turn off all power before installing floats in pump chamber. Failure to do so could result in serious or fatal electrical shock.

1. Use float label kit to identify and label cables on both the float and stripped ends (redundant off, low level, timer override, high level alarm). See schematic for float options.
2. Determine your normal operating level, as illustrated in **Figures 1-3**.
3. Mount float switches at appropriate levels as illustrated in **Figure 4**. Be sure the floats have free range of motion without touching each other or other equipment in the basin.
4. For mounting clamp installation: place the cord into the clamp as shown in **Figure 4**. Locate the clamp at the desired activation level and secure the clamp to the discharge pipe as shown in **Figure 4**.

**NOTE:** Do not install cord under hose clamp.

5. Tighten the hose clamp using a screwdriver. Over tightening may result in damage to the plastic clamp. Make sure the float cable is not allowed to touch the excess hose clamp band during operation.

**NOTE:** All hose clamp components are made of 18-8 stainless steel material. See your SJE-Rhombus® supplier for replacements.

6. If using an optional redundant off float, mount slightly below the low level cutout float, but above the pump as illustrated in **Figures 2 & 3**.
7. If using an optional timer override float, position it at a level in the basin as shown in **Figure 2 or 3**. Determine the pumping range for the SJE PumpMaster® pump switch as shown in **Figure 5**, and adjust for that range by setting the tether length.

Warranty void if panel is modified.

Call factory with servicing questions:

1-800-RHOMBUS  
(1-800-746-6287)

Manufactured by:

**SJE**  
**Rhombus**®

22650 County Highway 6 ■ P.O. Box 1708  
Detroit Lakes, Minnesota 56502 USA  
1-888-DIAL-SJE (1-888-342-5753)  
Phone: 218-847-1317 ■ Fax: 218-847-4617  
E-mail: customer.service@sjerrhombus.com  
Website: www.sjerrhombus.com

# Installation Instructions

## Mounting the Control Panel

1. Determine mounting location for panel. If distance exceeds the length of either the float switch cables or the pump power cables, splicing will be required. For outdoor or wet installation, we recommend the use of an SJE-Rhombus® liquid-tight junction box with liquid-tight connectors to make required connections. **You must use conduit sealant to prevent moisture or gases from entering the panel.**

2. Mount control panel.

**CAUTION:** Always use mounting devices furnished with control panel.

3. Determine conduit entrance locations on control panel. Check local codes and schematic for the number of power circuits required.

**CAUTION:** Be sure the incoming power, voltage, amperage, and phase meet the requirements of the pump motors being installed. If in doubt, see the pump identification plates for electrical requirements.

4. Drill proper size holes for type of connectors being used.

**CAUTION:** If using conduit, be sure that it is of adequate size to pull the pump and switch cables through.

5. Attach cable connectors and/or conduit connectors to control panel.

**FOR INSTALLATION WITHOUT A SPLICE, GO TO STEP 11; FOR INSTALLATION REQUIRING A SPLICE, FOLLOW STEPS 6-10.**

**Figure 9 - Timer detail**

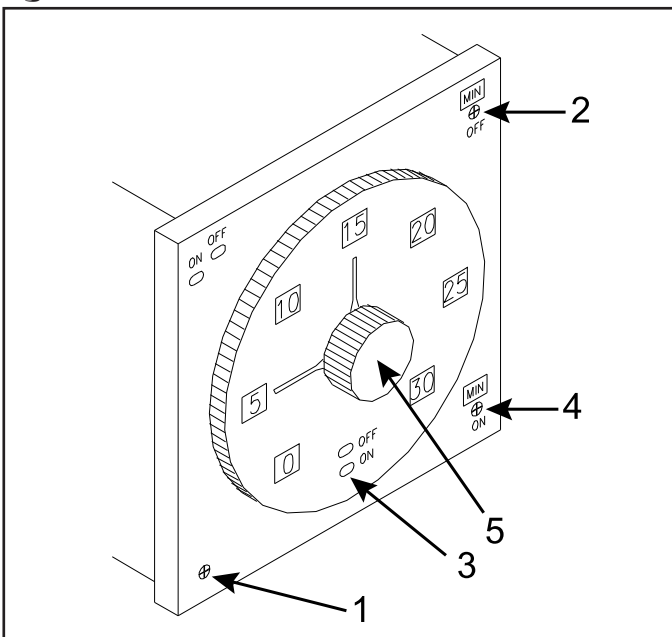

- Determine location for mounting junction box according to local code requirements. **Do not** mount the junction box inside the sump or basin.
- Mount junction box to proper support.
- Run conduit to junction box. Drill proper size holes for the type of conduit used. Attach liquid-tight connectors to junction box.
- Identify and label each wire before pulling through conduit into control panel and junction box. Make wire splice connections at junction box.
- Firmly tighten and seal all fittings on junction box. Insure all cable connectors are liquid tight and sealed.
- If a junction box is not required, pull cables through conduit into control panel.
- Connect "power-in" conductors, pump wires and float switch cables to the proper terminals per field wiring instructions.

**NOTE:** It is the recommendation of the factory to use separate pump and alarm power sources.

**VERIFY CORRECT OPERATION OF CONTROL PANEL AFTER INSTALLATION IS COMPLETE.**

## Setting the timer

**Remove the timer by clipping the tie strap and pulling it straight out of the socket.**

- Determine the pump "on & off" time and turn the adjustment screw **(1)** so that the most appropriate range of numbers (usable for both the on and off cycles) is visible in the windows on the dial face.
- Adjust the off time range selector **(2)** to the appropriate period. (e.g.: minutes).
- Adjust the outer dial **(3)** so the green pointer indicates the off time period required.
- Adjust the on timer range selector **(4)** to the appropriate period (e.g.: minutes).
- Adjust the inner dial **(5)** so the red pointer indicates the on time period required.
- When setting is complete, place the timer back in the socket.
- In the example shown, the pump would be off for 15 minutes and then on for 5 minutes. This cycle would continue as long as there was enough liquid in the tank to float the low level cutoff switch.

**NOTE:** "OFF" time is cycled first.

# Installation Instructions

**Figure 1 - Two float system**

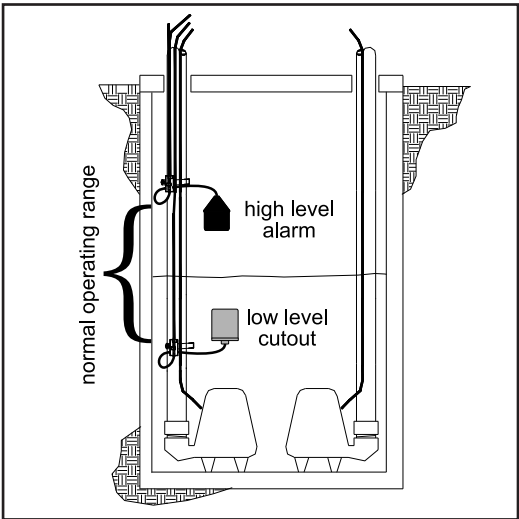

**Figure 3 - Four float system**

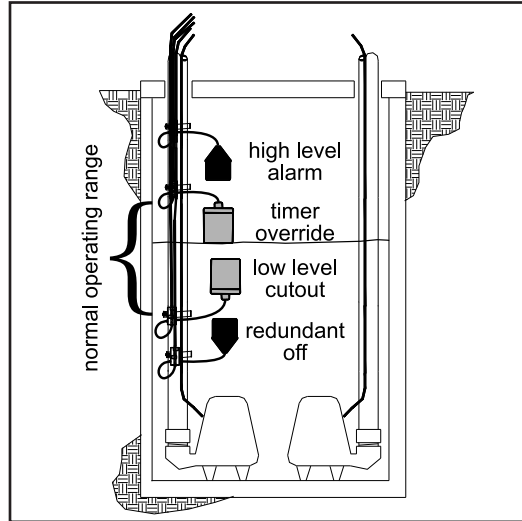

**Figure 2 - Three float systems**

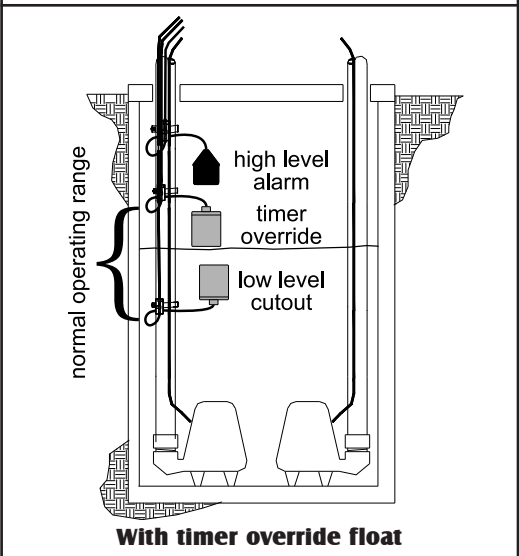
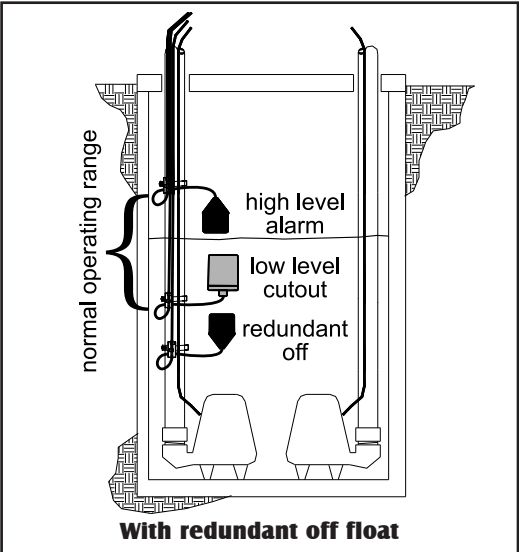

**Figure 4- Mounting clamp detail**

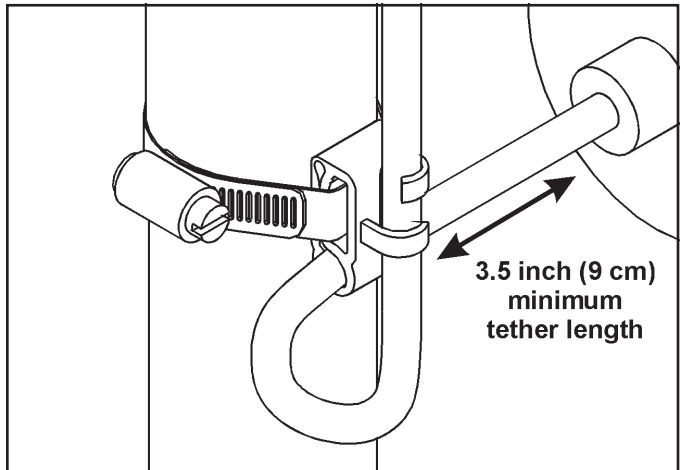

**Figure 5**

**SJE PumpMaster® Pumping Range  
In Inches (1 inch = 2.5 cm)**

tether length	3.5	6	10	14	18	22	24
pumping range	7	10	16	22	28	33	36

Use only as a guide. Pumping ranges are based on testing in non-turbulent conditions. Range may vary due to water temperature and cord shape.

**Note:** As the tether length increases, so does the variance of the pumping range.

# Operations & Troubleshooting



## WARNING!



### ELECTRICAL SHOCK HAZARD

Disconnect all power sources before servicing. Failure to do so could result in serious injury or death.

### Alarm Horn

Moving the test/normal/silence switch to the test position or activating the alarm float should turn on the alarm horn. If the horn does not sound, replace horn with same type.

### Alarm Light

Moving the test/normal/silence switch to the test position or activating the alarm float should turn on the alarm light. If the light does not activate, replace with bulb of same type.

### Float Controls

Check the floats during their entire range of operation. Clean, adjust, or replace damaged floats.

**Checking the float resistance** - The float resistance can be measured to determine if the float is operating correctly or if it is defective. Use the following procedure to measure the float resistance. **Warning: Disconnect all incoming power to panel. Failure to do so could result in serious or fatal electrical shock.**

1. Isolate the float by disconnecting one or both of the float leads from the float terminals.
2. Place one ohmmeter lead on one of the float wires, and the other ohmmeter lead on the other float wire.
3. Place the ohmmeter dial to read ohms and place on the R X 1 scale. With the float in the "off" position, the scale should read infinity (high resistance). Replace the float if you do not get this reading. With the float in the ON position, the scale should read nearly zero (very low resistance). Replace the float if you do not get this reading.

**NOTE: Readings may vary depending on the length of wire and accuracy of the measuring device.**

### Fuses

Check the continuity of the fuse. With power OFF, pull the fuse out of the fuse block. With the ohmmeter on the R X 1 scale, measure resistance. A reading of infinity indicates a blown fuse and must be replaced. Replace fuse with same type, voltage and amp rating.

### Magnetic Contactor Coils

**Warning: Disconnect all incoming power to panel. Failure to do so could result in serious or fatal electrical shock.** Check the coil by disconnecting one of the coil leads. Measure the coil resistance by setting the ohmmeter on the R X 1 scale. A defective coil will read zero or infinity, indicating a short or opened coil respectively. Replace defective contactor with same type.

DTD series control panels are available for use with two, three or four float combinations. In a two float system, one float in the tank is the "low level cutout" float while the other is a "high level alarm" float. The normal operating level should be between the "low level cutout" position and the "high level alarm" position.

A "redundant off" float (optional) is positioned slightly below the "low level cutout" grey float, but above the pump. The normal operating level shall be between the "low level cutout" position and the "high level alarm" position.

A "timer override" float (optional) gives you the option of pumping from the basin while the timer is in the "off" cycle. It is only intended for times of abnormally high liquid level intrushes. The normal operating level should be between the "low level cutout" float and the "timer override" float.

The control panel begins timing the "off" sequence when the "low level cutout" float is activated. Once the timer completes the "off" sequence, the timer will start a pump and continue to run until the programmed "on" sequence is complete. At this point the "off" sequence begins timing again and the cycle repeats.

### Circuit Breaker

Check each pole of the circuit breaker for proper resistance reading using the following procedure:

**Warning: Disconnect all incoming power to control panel. Failure to do so could result in serious or fatal electrical shock.**

1. Isolate the circuit breaker by disconnecting either the line side or load side wires.
2. Place the ohmmeter leads across the corresponding line and load terminals of each pole.
3. With the ohmmeter on the R X 1 scale and the breaker in the OFF position, the reading should be infinity (very high resistance). With the breaker in the ON position, the reading should be nearly zero ohms (very low resistance). If the readings are not as stated, replace the circuit breaker with one of the same ratings.

## SJE-Rhombus® Five-Year Limited Warranty

**SJE-RHOMBUS®** warrants to the original consumer that this product shall be free of manufacturing defects for five years after the date of consumer purchase. During that time period and subject to the conditions set forth below, **SJE-RHOMBUS®** will repair or replace, for the original consumer, any component which proves to be defective due to defective materials or workmanship of **SJE-RHOMBUS®**.

**ELECTRICAL WIRING AND SERVICING OF THIS PRODUCT MUST BE PERFORMED BY A LICENSED ELECTRICIAN.**

**THIS WARRANTY DOES NOT APPLY:** (A) to damage due to lightning or conditions beyond the control of **SJE-RHOMBUS®**; (B) to defects or malfunctions resulting from failure to properly install, operate or maintain the unit in accordance with printed instructions provided; (C) to failures resulting from abuse, misuse, accident, or negligence; (D) to units which are not installed in accordance with applicable local codes, ordinances, or accepted trade practices, and (E) to units repaired and/or modified without prior authorization from **SJE-RHOMBUS®**.

*Some states do not allow limitations on how long an implied warranty lasts, so the above limitation may not apply to you. Some states do not allow the exclusion or limitation of incidental or consequential damages, so the above limitation or exclusion may not apply to you. This warranty gives you specific legal rights, and you may also have other rights which vary from state to state.*

**TO OBTAIN WARRANTY SERVICE:** The consumer shall assume all responsibility and expense for removal, reinstallation, and freight. Any item to be repaired or replaced under this warranty must be returned to **SJE-RHOMBUS®**, or such place as designated by **SJE-RHOMBUS®**.

**ANY IMPLIED WARRANTIES OF MERCHANTABILITY OR FITNESS ARE LIMITED TO THE DURATION OF THIS WRITTEN WARRANTY. SJE-RHOMBUS® SHALL NOT, IN ANY MANNER, BE LIABLE FOR ANY INCIDENTAL OR CONSEQUENTIAL DAMAGES AS A RESULT OF A BREACH OF THIS WRITTEN WARRANTY OR ANY IMPLIED WARRANTY.**

### NOTICE!

Products returned must be cleaned, sanitized, or decontaminated as necessary prior to shipment to ensure that employees will not be exposed to health hazards in handling said material. All applicable laws and regulations shall apply.