

# Panel Wiring Diagram Model S2 PT



Orenco Systems<sup>®</sup>  
Incorporated

814 AIRWAY AVENUE

SUTHERLIN, OREGON

97479-9012

TELEPHONE:

(541) 459-4449

FACSIMILE:

(541) 459-2884

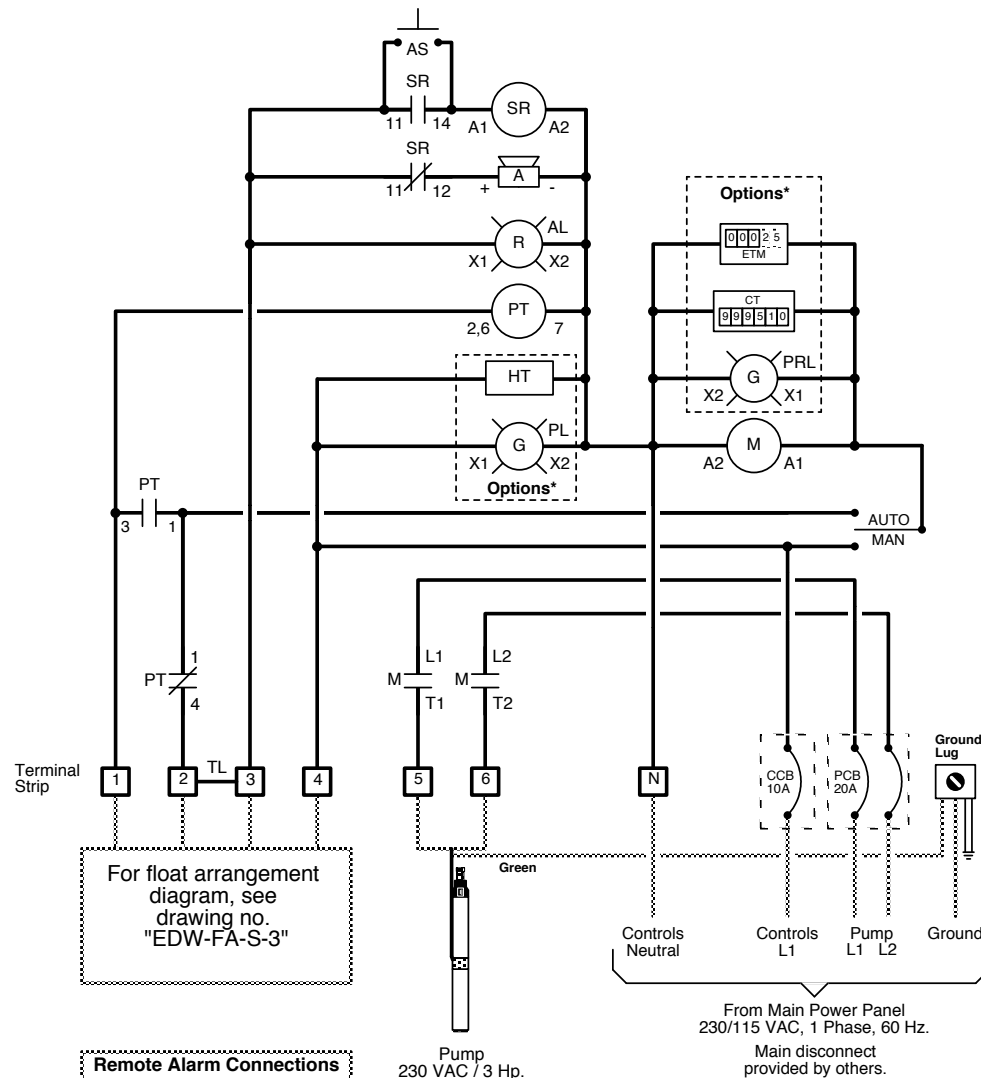

For float arrangement diagram, see drawing no. "EDW-FA-S-3"

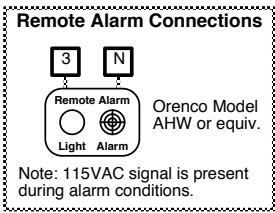

NOTE: Motors must have internal overload protection

Pump  
230 VAC / 3 Hp.  
1 Phase / 60 Hz.

## Simplex Operation

**High Level Alarm:** This float activates the alarm light and audible alarm when lifted. The audible alarm may be silenced by pressing the illuminated PUSH TO SILENCE button on the front of the control panel. The alarm light will remain on until the float is lowered.

**Timer Override On & Off:** This float turns on the pump when lifted and off when lowered.

**Timer On & Off:** This float turns off the programmable timer when lowered. When this float is lifted the timer will be restarted. Note: The timer will start with its off cycle.

**Programmable Timer:** The timer turns the pump on and off in a pre-set cycle. Note: The timer will start with its off cycle.

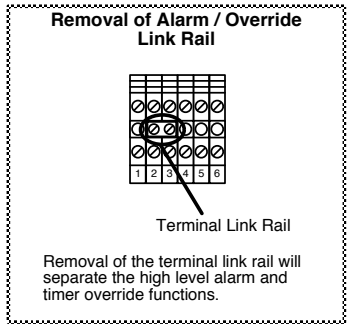

### Key

- = Factory Wire
- - - = Field Wire
- · - = Alternate Field Wire
- A = Audio Alarm, 115 VAC
- AL = Alarm Light
- AS = Audio Silence Switch
- CCB = Controls Circuit Breaker
- M = Motor Contactor
- PCB = Pump Circuit Breaker
- PT = Programmable Timer
- SR = Silence Control Relay
- TL = Terminal Link

### \*Options

- CT = Cycle Counter
- ETM = Elapsed Time Meter
- HT = Heater
- PL = Power Light
- PRL = Pump Run Light

## Power Wiring Options

### Two Circuits

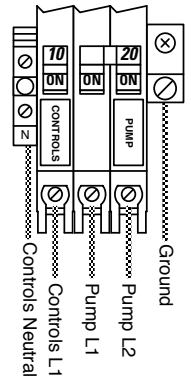

### One Circuit

