

Panel Wiring Diagram Model S1 RO DS SA 1 Hp Max

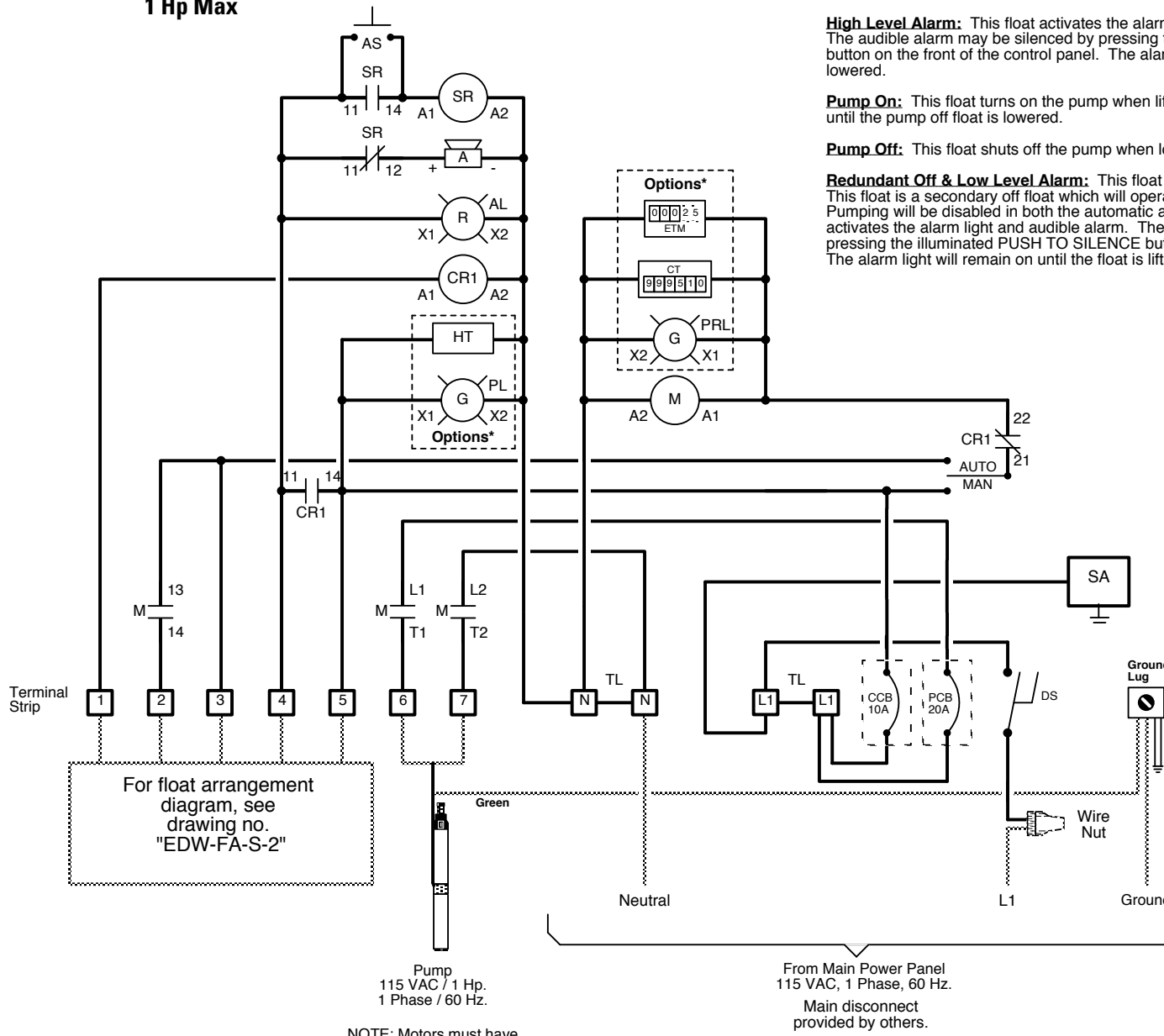

Simplex Operation

High Level Alarm: This float activates the alarm light and audible alarm when lifted. The audible alarm may be silenced by pressing the illuminated PUSH TO SILENCE button on the front of the control panel. The alarm light will remain on until the float is lowered.

Pump On: This float turns on the pump when lifted. The pump will continue to run until the pump off float is lowered.

Pump Off: This float shuts off the pump when lowered.

Redundant Off & Low Level Alarm: This float turns off the pump when lowered. This float is a secondary off float which will operate if the Pump Off float fails. Pumping will be disabled in both the automatic and manual modes. This float also activates the alarm light and audible alarm. The audible alarm may be silenced by pressing the illuminated PUSH TO SILENCE button on the front of the control panel. The alarm light will remain on until the float is lifted.

Key

- = Factory Wire
- = Field Wire
- - - = Alternate Field Wire
- A = Audio Alarm, 115 VAC
- AL = Alarm Light
- AS = Audio Silence Switch
- CCB = Controls Circuit Breaker
- CR1 = Redundant Off Relay
- DS = Disconnect Switch
- M = Motor Contactor
- PCB = Pump Circuit Breaker
- SA = Surge Arrester
- SR = Silence Control Relay
- TL = Terminal Link

*Options

- CT = Cycle Counter
- ETM = Elapsed Time Meter
- HT = Heater
- PL = Power Light
- PRL = Pump Run Light

Remote Alarm Connections

