

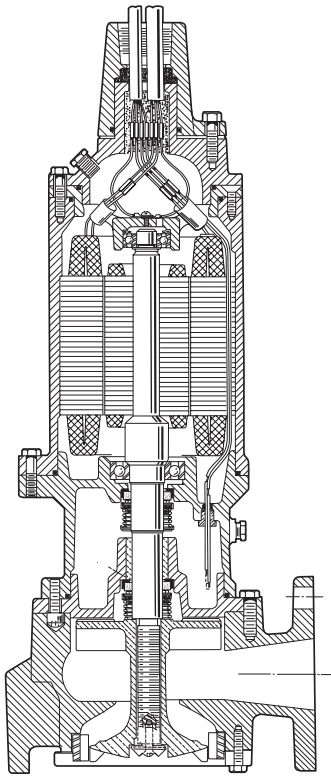

**MYERS®**

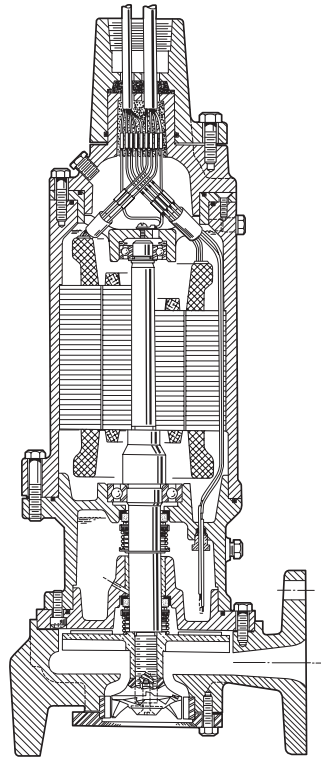

**HIGH CAPACITY  
GRINDER PUMP  
WG**



**HIGH HEAD  
GRINDER PUMP  
WGH**

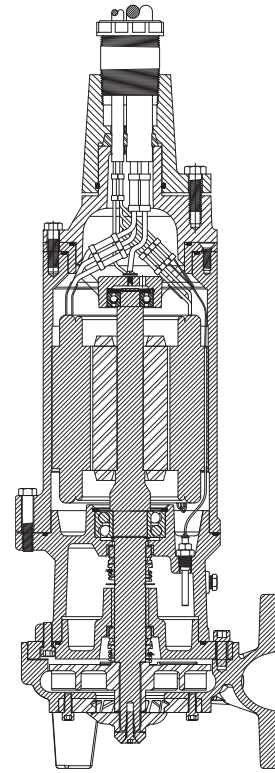

**HIGH HEAD AND  
HIGH CAPACITY VS30, VS50,  
VH30, VH50, VH75 SERIES**

# VS30, VH30, VS50, VH50 and VH75 WG30, WG30H, WG50, WG50H and WG75H **GRINDER PUMPS**

## **INSTALLATION AND SERVICE MANUAL**



NOTE! To the installer: Please make sure you provide this manual to the owner of the equipment or to the responsible party who maintains the system.

**Pump Models:** The 3, 5, and 7½ HP grinder pumps are made in four models, the WG, WGH, VS and VH. These pumps are made for single phase 230 volts and three phase for 200, 230, 460 and 575 volts.

**Instructions:** These instructions cover only the pump unit. Other instructions for lift-out rail system and electrical controls are included with those items. Complete disassembly instructions are furnished only to authorized service stations.

**CAUTION: PUMP IS NOT TO BE DISASSEMBLED IN THE FIELD EXCEPT AT AN AUTHORIZED SERVICE STATION OR AT THE MYERS® FACTORY. WARRANTY IS VOID IF PUMP IS TAKEN APART FOR ANY REASON EXCEPT TO REPLACE GRINDER IMPELLER AND GRINDER RING.**

**CALIFORNIA PROPOSITION 65 WARNING:**

**▲ WARNING** This product and related accessories contain chemicals known to the State of California to cause cancer, birth defects or other reproductive harm.

These pumps are designed for the rugged service of grinding and pumping commercial and industrial sewage. They are not intended for pumping heavy slurries or liquids containing abrasives or corrosive elements.

Three phase motors are generally used for commercial and industrial service, but single phase motors are available where 3 phase cannot be obtained, especially in rural areas. Transformers must be large enough to maintain full voltage for single phase. Low voltage on large single phase motors can cause considerable trouble and motors are not guaranteed to operate on low voltage. All single phase motors must have a special electrical control box furnished by Myers.

**INSTALLING SINGLE PHASE MOTORS WITH CONTROLS OTHER THAN MYERS VOIDS ALL WARRANTIES.**

Pump motor chamber and seal chamber are oil filled for long life and best heat transfer.

The seal chamber is provided with an electrode to give a signal to control panel if water enters the seal chamber due to worn or faulty lower seal.

Motor is provided with a heat sensor that automatically stops motor if overheating occurs for any reason. This sensor resets as soon as motor temperature drops to safe range. Additional overload heaters are used in the control box to trip under overload conditions.

**Motor Cords:** Each pump motor has two cords, one large power cord and one small control cord.

Both cords are the same for single and three phase. The wires are color coded blue, black, red and green. For 3 phase the blue, black and red lines are power lines and the green is ground. For single phase the black and blue lines are power and the red is for start winding and the green is ground. Per NEC, blue wire may be indicated by blue tape affixed to white wire.

Any three phase motor can be reversed by interchanging any two line leads. Single phase motor is single rotation only. Correct motor rotation is counterclockwise when looking at the grinder end of pump.

The black and blue leads of the control cord connect to heat sensor and the red conductors connect to seal failure; green is ground. Per NEC, blue wire may be indicated by blue tape affixed to white wire.

All green ground wires connect to screw terminal in motor connection housing and to grounding bar in electrical control box.

**IMPORTANT!** These ground wires must be connected in control box to grounding bar that is connected to a good outside ground. **MOTOR IS NOT SAFE UNLESS GROUNDED.**

**Installing Pump in Sump:** These pumps are usually installed in concrete or fiberglass basins with the lift-out rail system.

If pump is not installed with lift-out rail system it must be properly supported to discharge pipe so that space is provided under the pump for entrance of sewage. Pump inlet should not be closer than 5 inches from bottom of sump.

**Starting Pump After Installing in Sump Basin:** If pump is 3 phase, pump rotation must be checked. Before lowering pump into basin, connect power lines and start motor using H-O-A switch in the Hand position. Grinder impeller should turn counterclockwise when looking at grinder impeller. If rotation is wrong, interchange any two line leads at control box.

**CAUTION: Keep hands completely away from grinder impeller when making this check.**

Disconnect line leads from panel and mark wires so they can be reconnected in same manner as used for test.

**Three Phase Control Box:** Any suitable three phase control equipment can be used for simplex or duplex operation. These control boxes are also available from Myers. If other than Myers box is used, overload heaters must be selected in accordance with full load amp ratings.

**Single Phase Control Box:** Single phase pumps must use the Myers control box.

Warranty is void if non-Myers single phase control box is used.

## CHECKLIST IF PUMP DOES NOT OPERATE PROPERLY

**Checking for Moisture in Motor:** Use ohmmeter and set on highest scale. Readings on the large power cord between any of the conductors red, black, blue to green conductor or motor shell should be more than 500,000 ohms. Motor probably will run with a lower reading, but if pump is out of service and reading is below 500,000 ohms, the motor housing and stator should be serviced at an authorized service facility.

Readings should be taken with line leads disconnected from terminal strip.

**Resistance of Windings:** Every motor winding has a fixed resistance, and winding must check close to the values given to operate properly. This winding resistance also shows if motor is connected for voltage being used.

Use ohmmeter for this test and set on scale to read directly in ohms.

## REPLACING GRINDER COMPONENTS

This is the only disassembly operation allowed in the field. All other repairs must be done at the factory or at an authorized service facility.

**IMPORTANT!** Pump should be thoroughly cleaned of trash and deposits before starting disassembly operations.

**CAUTION: DISCONNECT ALL POWER AND CONTROL WIRES TO MOTOR AT CONTROL PANEL BEFORE STARTING DISASSEMBLY OPERATION. NEVER RELY ON OPENING CIRCUIT BREAKER ONLY.**

## DISASSEMBLY OF STATIONARY CUTTER PLATE AND ROTATING CUTTER: VS and VH SERIES

1. Remove retaining washer and screw from end of shaft. A screwdriver can be used to hold the shaft in place by wedging it between one of the four socket head cap screws and the rotating cutter while loosening the screw.
2. Using a rubber mallet, or soft metal hammer, bump rotating cutter in counterclockwise direction as thread is right-hand. Unthread rotating cutter from shaft. Be careful to not lose ring shims that space the rotating cutter from the stationary cutter plate.
3. Remove four socket head cap screws holding the stationary cutter plate to the volute. Remove stationary cutter from volute. If stationary cutter is stuck, the socket head cap screws can be threaded into tapped back-off holes in plate. Tighten screws to remove plate from volute.
4. Inspect rotating cutter and stationary cutter plate for wear and replace if worn.
5. Make sure pocket in volute is clean and reinstall stationary cutter plate using the four socket head cap screws. Apply blue Loctite® to the threads. Do not overtighten cap screws.
6. Replace ring shims (if removed from the shaft) and thread rotating cutter onto shaft. Make sure threads on shaft are clean and use Never-Seez® or other graphite compound on threads before replacing rotating cutter.
7. Using a rubber mallet, or soft metal hammer, bump rotating cutter in clockwise direction to make sure it is seated on the impeller.
8. To ensure proper operation of the cutter mechanism, the gap between the stationary cutter plate and rotating cutter must be no more than .010". To check the gap use a .010" feeler gauge. If the .010" feeler gauge does not fit between the surface of the stationary cutter and rotating cutter and the motor shaft turns freely, the gap is set correctly. If the .010" feeler gauge fits between the surfaces, shims must be removed to close the gap.
9. Replace retaining washer and screw in the end of the shaft. Be sure screw is tight. A screwdriver can be used to hold the shaft in place by wedging it between one of the four socket head cap screws and the rotating cutter while tightening the screw.
10. Be sure shaft turns freely after reassembly. Some drag will occur due to the seal, but there should be no binding or tight spots when turning the rotating cutter.
11. If rotating cutter rubs or drags on stationary cutter plate, recheck gap and re-shim rotating cutter.

## REPLACING GRINDER IMPELLER AND GRINDER SHREDDING RING: WG AND WGH SERIES

1. Remove screws from holding ring and remove ring.
2. Use two screwdrivers, one each on opposite sides of ring, and pry off snap ring that holds shredding ring in place. Remove shredding ring.
3. Hold impeller by prying against impeller cutting bar and remove cap screw from end of shaft.
4. Use large screwdriver in slot in end of shaft and bump on cutter vane with plastic hammer. Bump in counterclockwise direction as thread is right hand. It may take several bumps to loosen impeller.  
  
If impeller cannot be loosened, it will be necessary to take unit to service facility for service. **DON'T CONTINUE TO POUND ON IMPELLER AS IMPELLER AND SHAFT CAN BE DAMAGED.**
5. If impeller comes off easily, clean up and replace if worn.

6. Be sure pump impeller has not loosened when grinder impeller is removed. This can be checked on reassembly of grinder impeller and shredding ring. Tips of impeller cutter vanes should extend about 1/8" below bottom of shredding ring. If more than 1/8" extends below ring it means pump impeller has loosened.

Remove grinder impeller and ring, remove bolts from pump case and remove case. Use back-off screws in motor mounting plate to pry loose from pump case.

7. After case is removed wrap emery paper around shaft and hold with vise grip pliers. Use cloth on impeller and screw up against shroud. Now pump can be reassembled.
8. Clean all threads with wire brush and file smooth any threads that may be nicked.
9. Use graphite compound on threads before replacing grinder impeller.
10. Be sure cap screw in bottom of shaft is tight. Hold impeller with screwdriver between cutter bar and teeth of shredding ring while tightening cap screw.
11. Be sure impeller turns free by hand after reassembly. Some drag will occur due to seals but there should be no binding or tight spots when turning the grinder impeller.
12. ALWAYS use a rag on the impellers when turning to prevent cutting hands on the sharp corners of shredding ring.

## **PUMP TROUBLESHOOTING**

### **TROUBLE CHECKLIST**

Troubles listed are generally caused by the pump. Other troubles can occur from faulty control box operation. These will be listed with the control box instructions.

#### **Pump runs but does not pump liquid from base.**

1. Pump impeller may be air locked; this occasionally occurs on a new installation. Start and stop pump several times to purge air.
2. Run additional water into basin so that pump will be submerged deeper to clear air.
3. If pump is three phase, rotation may be wrong. See instructions for checking proper rotation.
4. If air does not clear it may be necessary to lift pump out of sealing elbow and start motor to allow pump to pump for a few seconds. Air vent hole is provided in pump case, so some water will flow from this hole when pump is operating. If vent hole gets clogged, clean out.

5. If pump has been installed for some time and does not pump, it may be clogged at grinder inlet.
6. Discharge gate valve may be closed.
7. Discharge check valve may be clogged or have a broken clapper.
8. Discharge head may be too high. Check elevation. Maximum pump head at zero flow is shown on pump curve sheet.
9. If above checks do not locate trouble, motor rotor may be loose on shaft which allows motor to run but will not turn impeller or only at low RPM.

#### **Red light comes on at control box.**

1. This indicates some water has leaked past the lower seal and has entered the seal chamber and made contact with the electrode probe. Pump must be removed from basin immediately for replacement of lower seal. This preventive repair will save an expensive motor.

#### **Overload trips at control box and alarm buzzer or flashing red light comes on due to high water level in basin.**

1. Push in on red reset button to reset overload. If overload trips again after short run, pump has some damage and must be removed from basin for checking.
2. Trouble may be from clogged grinder causing motor to overload or could be from failed motor.
3. Trouble may be from faulty component in control box. Always check control box before removing pump.

#### **Yellow run light stays on continuously.**

1. Indicates H-O-A switch may be in the Hand position.
2. Level control switch may have failed causing pump to continue to operate when water is below lower weight, or lower weight may have dropped off.
3. Grinder assembly may be partially clogged causing pump to operate at much reduced capacity.
4. Gate valve or check valve may be clogged causing low pump flow.
5. Pump may be air locked.

#### **Circuit breaker trips.**

1. Reset breaker by pushing clear down on handle then back to On position. If breaker trips again in few seconds it indicates excessive load probably caused by a short in the motor or control box. Check out instructions given with control box before pulling pump.
2. If this condition happens after an electrical storm, motor or control box may be damaged by lightning.
3. Resistance reading of the motor with lead wires disconnected from the control box can determine if trouble is in motor or control box.

**Pump is noisy and pump rate is low.**

1. Grinder assembly may be partially clogged with some foreign objects causing noise and overload on the motor.
2. Grinder impeller may be rubbing on grinder ring due to bent shaft or misalignment.

**Grease and solids have accumulated around pump and will not pump out of basin.**

1. Lower weight of level switch may be set too high. Set bottom of lower weight even with bottom of inlet flange to grinder.

2. Run pump on Hand operation for several minutes with small amount of water running into basin to clean out solids and grease. This allows pump to break suction and surge which will break up the solids. If level switch lower weight is set properly this condition generally will not occur.
3. Trash may have accumulated around lower weight causing pump to turn off too soon. Clean trash from weight and suspension cable.

**WIRING DIAGRAMS**

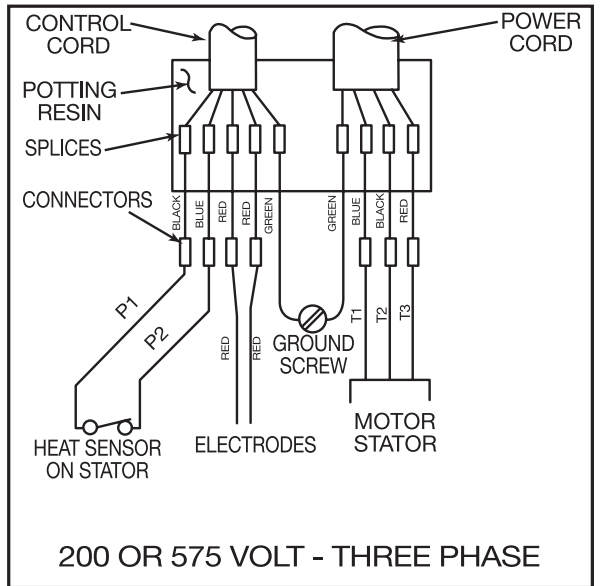
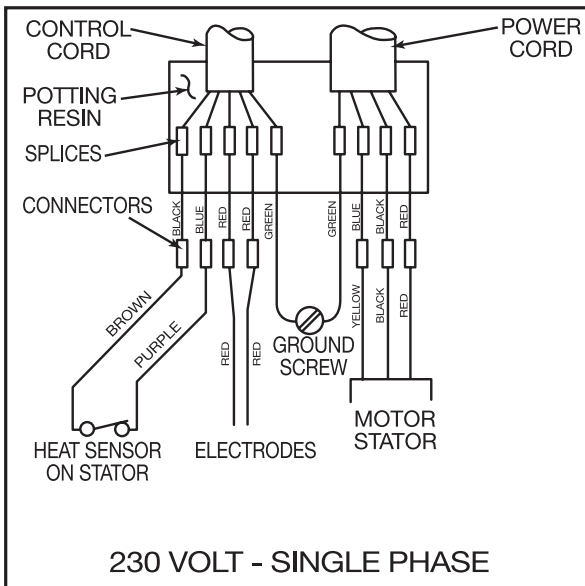
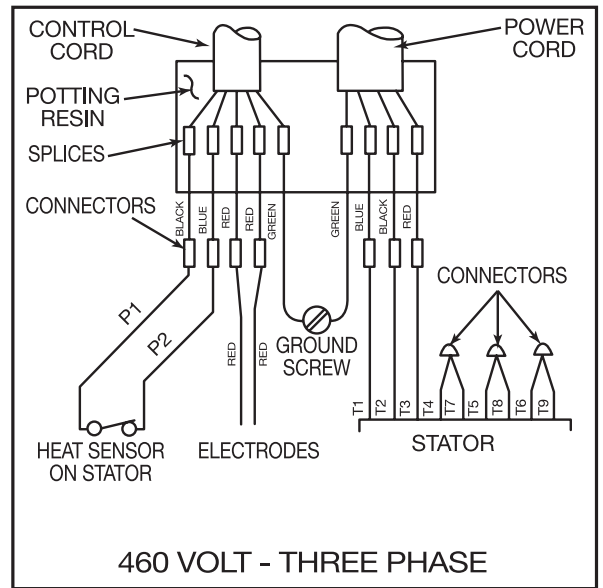
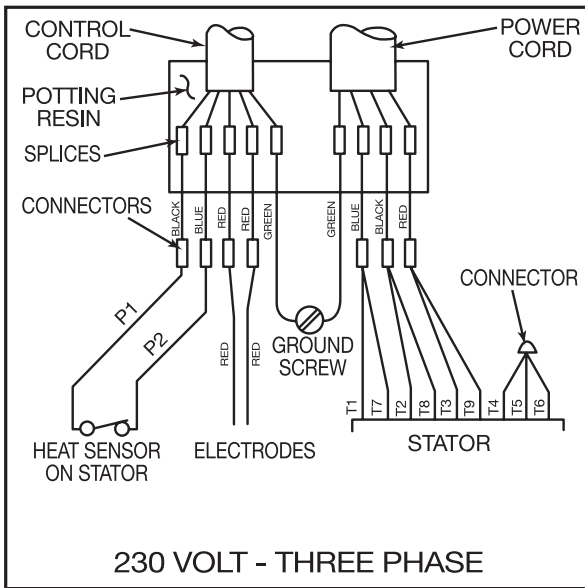

# WG30 & WG50 SUBMERSIBLE GRINDER PUMPS PARTS LIST

Covers 3 & 5 HP – 1 & 3 Phase – For pumps manufactured after March 1986

Ref. No.	Description	Qty.	Part No.
1	WG30 35' CORD ASSEMBLY 14-4	1	22569B104
	WG30/50 35' CORD ASSEMBLY 10-4	1	22569B031
	WG30/50 35' CORD ASSEMBLY 8-4 SOOW	1	22569B032
	WG30/50 35' CORD ASSEMBLY 8-4 W	1	22569B102
2	CONNECTOR	3	12672A003
3	PIPE PLUG, 1/4" NPT, HEX HD.	2	05022A092
4	O-RING, 4-7/8" x 4-5/8" x 1/8"	1	05876A123
5	CAP SCREW, HEX HD., 7/16"-14 x 1-1/2"	4	19102A006
6	CAP, UPPER BEARING	1	22590B000
7	O-RING, 5-1/2" x 5-1/4" x 1/8"	1	05876A112
8	MACHINE SCREW, #10-24 x 3/8" LG.	1	05434A043
9	LOCKWASHER, #10	1	06107A015
10	TUBE, PLASTIC, 1-1/4" LG.	2	10649A102
	TUBE, PLASTIC, 3" LG.	2	10649A116
11	HOUSING, MOTOR	1	22571D000
12	WASHER, SUPPORT	1	05030A215
13	CAP SCREW, SOCKET HD., 3/8"-16 x 1-1/4"	4	06106A027
14	LUBRICANT, NEVER SEEZ® CAT. NO. NSBT-8, 8 OZ. CAN	1	22386A000
15	GASKET, VELLUMOID	1	22581A000
16	CASE, VOLUTE	1	22582D000
17	MACHINE SCREW, SOCKET FLAT HD., 5/16"-18 x 1-1/4"	1	07597A021
18	RING, RETAINING	1	12558A025
19	RETAINER, IMPELLER	1	22585A000
20	MACHINE SCREW, SOCKET FLAT HD. 5/16"-18 x 1"	2	07597A017
21	WASHER, FINGER SPRING	2	19331A006
22	BEARING, BALL	1	08565A022
23	ROTOR W/SHAFT SHAFT ONLY (FOR ALL 3 & 5 HP UNITS)	1	See Chart 22573C200
24	STATOR	1	See Chart
25	BEARING, BALL	1	08565A023
26	HOUSING, SEAL	1	22576D010
27	SEAL, 1-1/4" SHAFT	2	22577A000
28	RING, RETAINING	1	12558A008
29	O-RING, 7" x 6-3/4" x 1/8"	1	05876A114
30	ELECTRODE, WIRE	2	22578A100
31	SEAL LEAK	1	25343A100
32	CAP SCREW, HEX HD., 7/16"-14 x 2-1/4"	4	19102A023
33	HOUSING, LOWER SEAL, W/BEARING	1	22580C000
34	O-RING, 6" x 5-3/4" x 1/8"	1	05876A113
35	CAP SCREW, HEX HD., 7/16"-14 x 1-1/4"	4	06106A063
36	IMPELLER, PUMP, 3 HP	1	22583B010
	IMPELLER, PUMP, 5 HP-3Ø	1	22583B000
37	IMPELLER, GRINDER	1	22584C000
38	RING, SHREDDING	1	22586B000
39	CAP SCREW, HEX HD., 3/8"-16 x 1"	4	19101A010
40	CLAMP, SHREDDING RING	1	22587C000

Pump Cat. No.	(23) Rotor w/Shaft	(24) Stator Only	Stator w/Housing
WG30-01	22572C103	22574C218	22571D44SK
WG30-21	22572C103	22574C200	22571D220K
WG30-03	22572C102	22574C201	22571D225K
WG30-23	22572C102	22574C202	225710231K
WG30-43	22572C102	22574C202	22571D231K
WG30-53	22572C102	22574C204	22571D240K
WG50-01	22572C103	22574C218	22571D445K
WG50-21	22572C103	22574C200	225710220K
WG50-03	22572C102	22574C201	22571D225K
WG50-23	22572C102	22574C202	225710231K
WG50-43	22572C102	22574C202	22571D231K
WG50-53	22572C102	22574C204	22571D240K

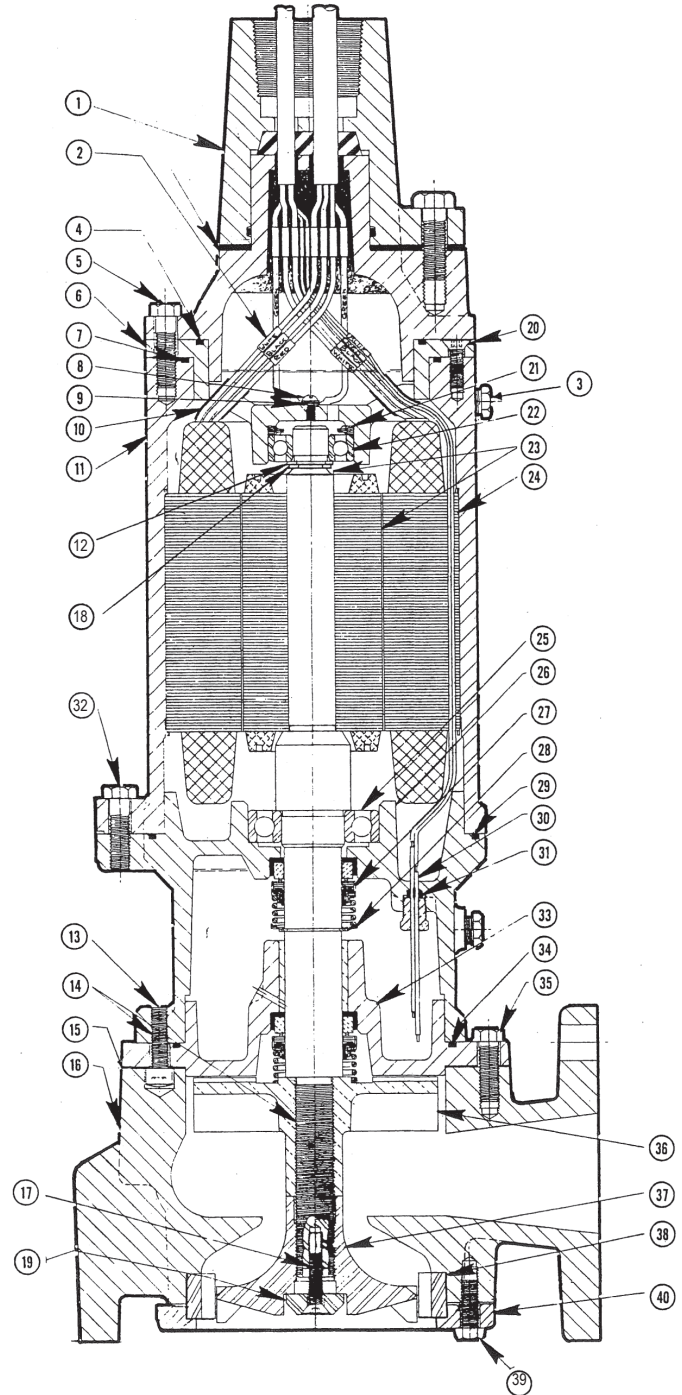

# WG30H, WG50H & WG75H SUBMERSIBLE GRINDER PUMPS

Covers 3 & 5 HP – 1 & 3 Phase & 7-1/2 HP – 3 Phase

Ref. No.	Description	Qty.	Part No.
1	WG30H/50H/75H 35' CORD ASSEMBLY 14-4	1	22569B104
	WG30H/50H 35' CORD ASSEMBLY 10-4	1	22569B031
	WG30H/50H/75H 35' CORD ASSEMBLY 8-4 SOOW	1	22569B032
	WG50H 35' CORD ASSEMBLY 8-4 W	1	22569B102
2	CONNECTOR	3	12672A003
3	PIPE PLUG, 1/4" NPT, HEX HD.	2	05022A092
4	O-RING, 4-7/8" x 4-5/8" x 1/8"	1	05876A123
5	CAP SCREW, HEX HD., 7/16"-14 x 1-1/2"	4	19102A006
6	CAP, UPPER BEARING	1	22590B000
7	O-RING, 5-1/2" x 5-1/4" x 1/8"	1	05876A112
8	MACHINE SCREW, #10-24 x 3/8" LG.	1	05434A043
9	LOCKWASHER, #10	1	06107A015
10	TUBE, PLASTIC, 1-1/4" LG.	2	10649A102
	TUBE, PLASTIC, 3" LG.	2	10649A116
11	HOUSING, MOTOR	1	22571D000
12	WASHER, SUPPORT	1	05030A215
13	CAP SCREW, SOCKET HD., 3/8"-16 x 1"	4	06106A028
14	LUBRICANT, NEVER SEEZ® CAT. NO. NSBT-8, 8 OZ. CAN	1	22386A000
15	GASKET, VELLUMOID	1	05231A078
16	CASE, VOLUTE	1	22639D000
17	MACHINE SCREW, SOCKET FLAT HD., 5/16"-18 x 1-1/4"	1	07597A021
18	RING, RETAINING	1	12558A025
19	RETAINER, IMPELLER	1	22585A000
20	MACHINE SCREW, SOCKET FLAT HD., 5/16"-18 x 1"	2	07597A017
21	WASHER, FINGER SPRING	2	19331A006
22	BEARING, BALL	1	08565A022
23	ROTOR W/SHAFT SHAFT ONLY (FOR ALL 3, 5, 7-1/2 HP UNITS)	1 1	See Chart 22636C102
24	STATOR	1	See Chart
25	BEARING, BALL	1	08565A023
26	HOUSING, SEAL	1	22576D010
27	SEAL, 1-1/4" SHAFT	2	22577A000
28	RING, RETAINING	1	12558A008
29	O-RING, 7" x 6-3/4" x 1/8"	1	05876A114
30	ELECTRODE WIRE	2	22578A100
31	SEAL LEAK	1	25343A100
32	CAP SCREW, HEX HD., 7/16"-14 x 2-1/4"	4	19102A023
33	HOUSING, LOWER SEAL, W/BEARING	1	22638C000
34	O-RING, 6" x 5-3/4" x 1/8"	1	05876A113
35	CAP SCREW, HEX HD., 7/16"-14 x 1-1/4"	4	06106A063
36	IMPELLER, PUMP, 3 HP	1	22640C002
	IMPELLER, PUMP, 5 HP	1	22640C003
	IMPELLER, PUMP, 7-1/2 HP	1	22640C001
37	IMPELLER, GRINDER	1	26010B000
38	RING, SHREDDING	1	*25134B000
39	CAP SCREW, HEX HD., 3/8"-16 x 1"	4	19101A010
40	CLAMP, SHREDDING RING	1	22643B000

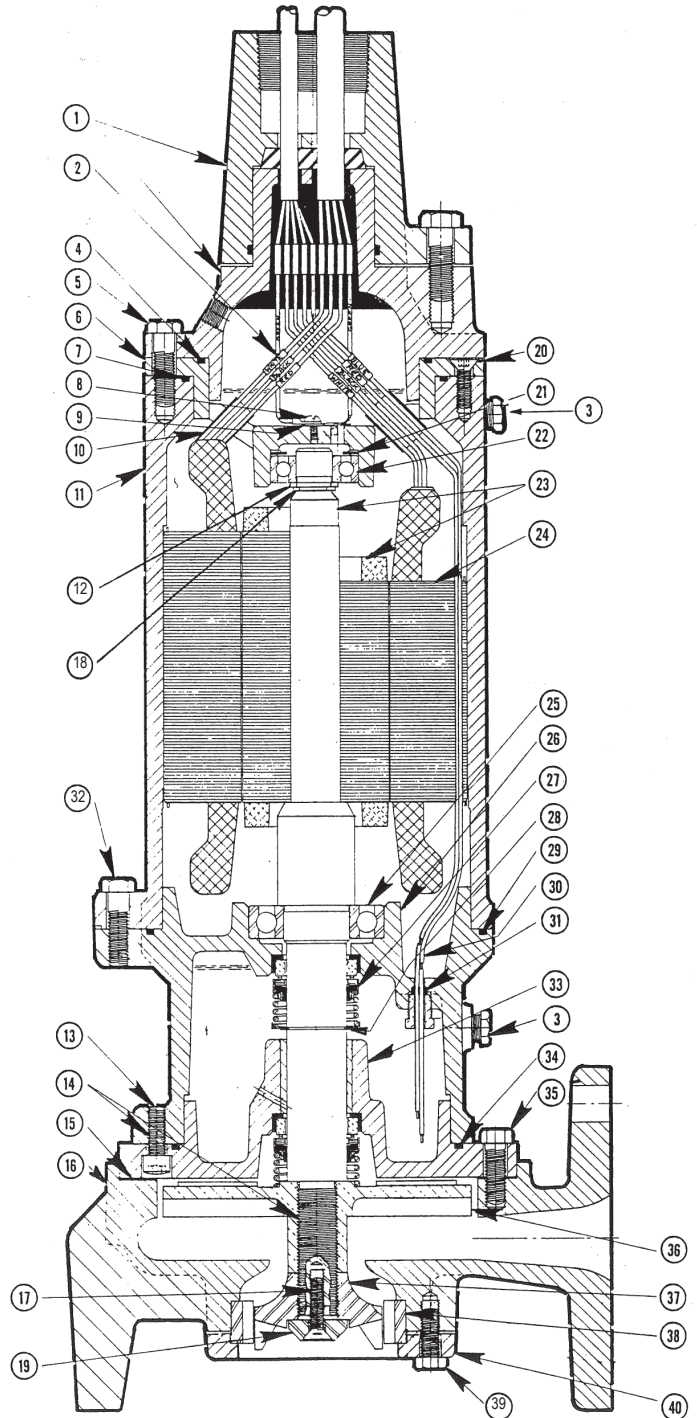

Pump Cat. No.	(23) Rotor w/Shaft	(24) Stator Only	Stator w/Housing
WG30H-21	22636C101	22574C210	22571D245K
WG30H-03	22636C100	22574C211	22571D250K
WG30H-23	22636C100	22574C212	22571D255K
WG30H-43	22636C100	22574C212	22571D255K
WG30H-53	22636C100	22574C214	22571D265K
WG50H-21	22636C103	22574C200	22571D220K
WG50H-03	22636C102	22574C201	22571D225K
WG50H-23	22636C102	22574C202	22571D231K
WG50H-43	22636C102	22574C202	22571D231K
WG50H-53	22636C102	22574C204	22571D240K
WG75H-03	22636C102	22574C201	22571D225K
WG75H-23	22636C102	22574C202	22571D231K
WG75H-43	22636C102	22574C202	22571D231K
WG75H-53	22636C102	22574C204	22571D240K

\*Effective after Sept. 1, 1990. New impeller and ring are interchangeable with previous impeller and ring.

# VS30 & VS50 SUBMERSIBLE GRINDER PUMPS PARTS LIST

Covers 3 & 5 HP – 1 & 3 Phase

Ref. No.	Description	Qty.	Part No.
1	VS30 35' CORD ASSEMBLY 14-4	1	22569B104
	VS30/50 35' CORD ASSEMBLY 10-4	1	22569B031
	VS30/50 35' CORD ASSEMBLY 8-4 SOOW	1	22569B032
	VS30/50 35' CORD ASSEMBLY 8-4 W	1	22569B102
2	CONNECTOR	3	12672A003
3	PIPE PLUG, 1/4" NPT, HEX HD.	2	05022A092
4	O-RING, 4-7/8" x 4-5/8" x 1/8"	1	05876A123
5	CAP SCREW, HEX HD., 7/16"-14 x 1-1/2"	4	19102A006
6	CAP, UPPER BEARING	1	22590B000
7	O-RING, 5-1/2" x 5-1/4" x 1/8"	1	05876A112
8	MACHINE SCREW, #10-24 x 3/8" LG.	1	05434A043
9	LOCKWASHER, #10	1	06107A015
10	TUBE, PLASTIC, 1-1/4" LG.	2	10649A102
	TUBE, PLASTIC, 3" LG.	2	10649A116
11	HOUSING, MOTOR	1	22571D000
12	N/A		N/A
13	CAP SCREW, SOCKET HD., 3/8"-16 x 1-1/4"	4	06106A027
14	LUBRICANT, NEVER SEEZ® CAT. NO. NSBT-8, 8 OZ. CAN	1	22386A000
15	GASKET, VELLUMOID	1	22581A000
16	CASE, VOLUTE	1	22639D001
17	MACHINE SCREW, SOCKET FLAT HD., 5/16"-18 x 1-1/4"	1	07597A021
18	RING, RETAINING	1	12558A025
19	RETAINER, IMPELLER	1	22585A000
20	MACHINE SCREW, SOCKET FLAT HD., 5/16"-18 x 1"	2	07597A017
21	WASHER, FINGER SPRING	2	19331A006
22	BEARING, BALL	1	08565A022
23	ROTOR W/SHAFT	1	See Chart
	SHAFT ONLY	1	22637C202
24	STATOR	1	See Chart
25	BEARING, BALL	1	071670211
26	HOUSING, SEAL	1	22576D020P
27	SEAL, 1-1/4" SHAFT	2	22577A000
28	RING, RETAINING	1	12558A008
29	O-RING, 7" x 6-3/4" x 1/8"	1	05876A114
30	ELECTRODE, WIRE	2	22578A100
31	PROBE, SEAL FAIL	2	25343A100
32	CAP SCREW, HEX HD., 7/16"-14 x 2-1/4"	4	19102A023
33	HOUSING, LOWER SEAL, W/BEARING	1	22638C000
34	O-RING, 6" x 5-3/4" x 1/8"	1	05876A113
35	SCREW, CAP HEX HD., 7/16"-14 x 1"	4	19102A021
36	IMPELLER, PUMP, 3HP	1	22640C378
	IMPELLER, PUMP, 5HP-3ø	1	22640C372
37	CUTTER, ROTATING	1	28183B000
38	CUTTER, STATIONARY, VS	1	28182B000
39	SCREW, CAP, SOCKET HD., 5/16"-18 x 3/4"	4	001780011
41	RING, RETAINING	1	07756A015
42	RING, RETAINING	1	12558A037
43	SCREW, MACH., 6-32 x 1/4"	1	05434A025
44	SHIM, .875 ID X 1.25 OD X .010	1	006280621
	SHIM, .875 ID X 1.25 OD X .005	1	006280611

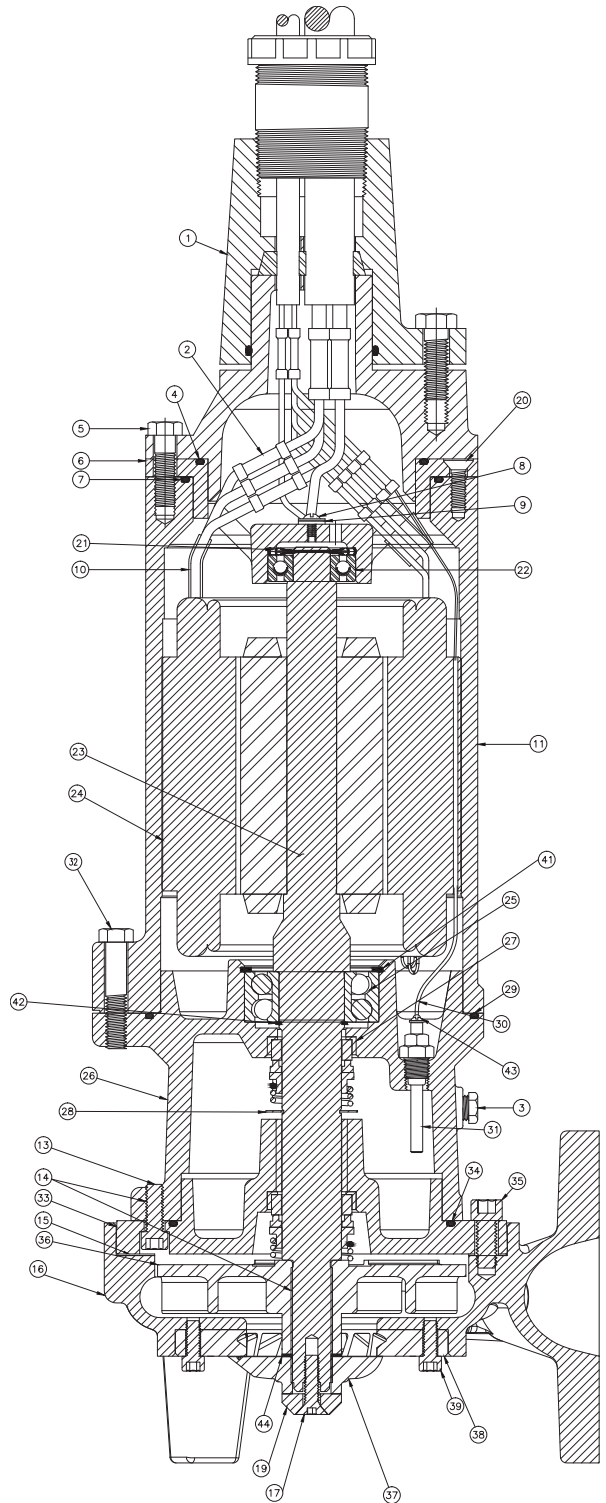

Pump Cat. No.	Rotor w/Shaft	Stator Only	Stator w/Housing
VS30-21	28208C103	22574C200	22571D220K
VS30-03	28208C102	22574C201	22571D225K
VS30-23	28208C102	22574C202	22571D231K
VS30-43	28208C102	22574C203	22571D231K
VS30-53	28208C102	22574C204	22571D240K
VS50-21	28208C103	22574C200	22571D220K
VS50-03	28208C102	22574C201	22571D225K
VS50-23	28208C102	22574C202	22571D231K
VS50-43	28208C102	22574C203	22571D231K
VS50-53	28208C102	22574C204	22571D240K



# VH30, VH50 & VH75 SUBMERSIBLE GRINDER PUMPS

Covers 3 & 5 HP – 1 & 3 Phase & 7-1/2 HP – 3 Phase

Ref. No.	Description	Qty.	Part No.
1	VH30H/50H/75H 35' CORD ASSEMBLY 14-4	1	22569B104
	VH30H/50H 35' CORD ASSEMBLY 10-4	1	22569B031
	VH30H/50H/75H 35' CORD ASSEMBLY 8-4 SOOW	1	22569B032
	VH50H 35' CORD ASSEMBLY 8-4 W	1	22569B102
2	CONNECTOR	3	12672A003
3	PIPE PLUG, 1/4" NPT, HEX HD.	2	05022A092
4	O-RING, 4-7/8" x 4-5/8" x 1/8"	1	05876A123
5	CAP SCREW, HEX HD., 7/16"-14 x 1-1/2"	4	19102A006
6	CAP, UPPER BEARING	1	22590B000
7	O-RING, 5-1/2" x 5-1/4" x 1/8"	1	05876A112
8	MACHINE SCREW, #10-24 x 3/8" LG.	1	05434A043
9	LOCKWASHER, #10	1	06107A015
10	TUBE, PLASTIC, 1-1/4" LG.	2	10649A102
	TUBE, PLASTIC, 3" LG.	2	10649A116
11	HOUSING, MOTOR	1	22571D000
12	N/A		N/A
13	CAP SCREW, SOCKET HD., 3/8"-16 x 1"	4	06106A028
14	LUBRICANT, NEVER SEEZ® CAT. NO. NSBT-8, 8 OZ. CAN	1	22386A000
15	GASKET, VELLUMOID	1	05231A078
16	CASE, VOLUTE	1	22639D001
17	MACHINE SCREW, SOCKET FLAT HD., 5/16"-18 x 1-1/4"	1	07597A021
18	RING, RETAINING	1	12558A025
19	RETAINER, IMPELLER	1	22585A000
20	MACHINE SCREW, SOCKET FLAT HD., 5/16"-18 x 1"	2	07597A017
21	WASHER, FINGER SPRING	2	19331A006
22	BEARING, BALL	1	08565A022
23	ROTOR W/SHAFT	1	See Chart
	SHAFT ONLY	1	22637C202
24	STATOR	1	See Chart
25	BEARING, BALL	1	071670211
26	HOUSING, SEAL	1	22576D020P
27	SEAL, 1-1/4" SHAFT	2	22577A000
28	RING, RETAINING	1	12558A008
29	O-RING, 7" x 6-3/4" x 1/8"	1	05876A114
30	ELECTRODE, WIRE	2	22578A100
31	PROBE, SEAL FAIL	2	25343A100
32	CAP SCREW, HEX HD., 7/16"-14 x 2-1/4"	4	19102A023
33	HOUSING, LOWER SEAL, W/BEARING	1	22638C000
34	O-RING, 6" x 5-3/4" x 1/8"	1	05876A113
35	SCREW, CAP HEX HD., 7/16"-14 x 1"	4	19102A021
36	IMPELLER, PUMP, 3HP	1	22640C374
	IMPELLER, PUMP, 5HP	1	22640C388
	IMPELLER, PUMP, 7-1/2HP	1	22640C387
37	CUTTER, ROTATING	1	28183B000
38	CUTTER, STATIONARY, VH	1	28191B000
39	SCREW, CAP, SOCKET HD., 5/16"-18 x 3/4"	4	001780011
41	RING, RETAINING	1	07756A015
42	RING, RETAINING	1	12558A037
43	SCREW, MACH., 6-32 x 1/4"	1	05434A025
44	SHIM, .875 ID x 1.25 OD x .010	1	006280621
	SHIM, .875 ID x 1.25 OD x .005	1	006280611

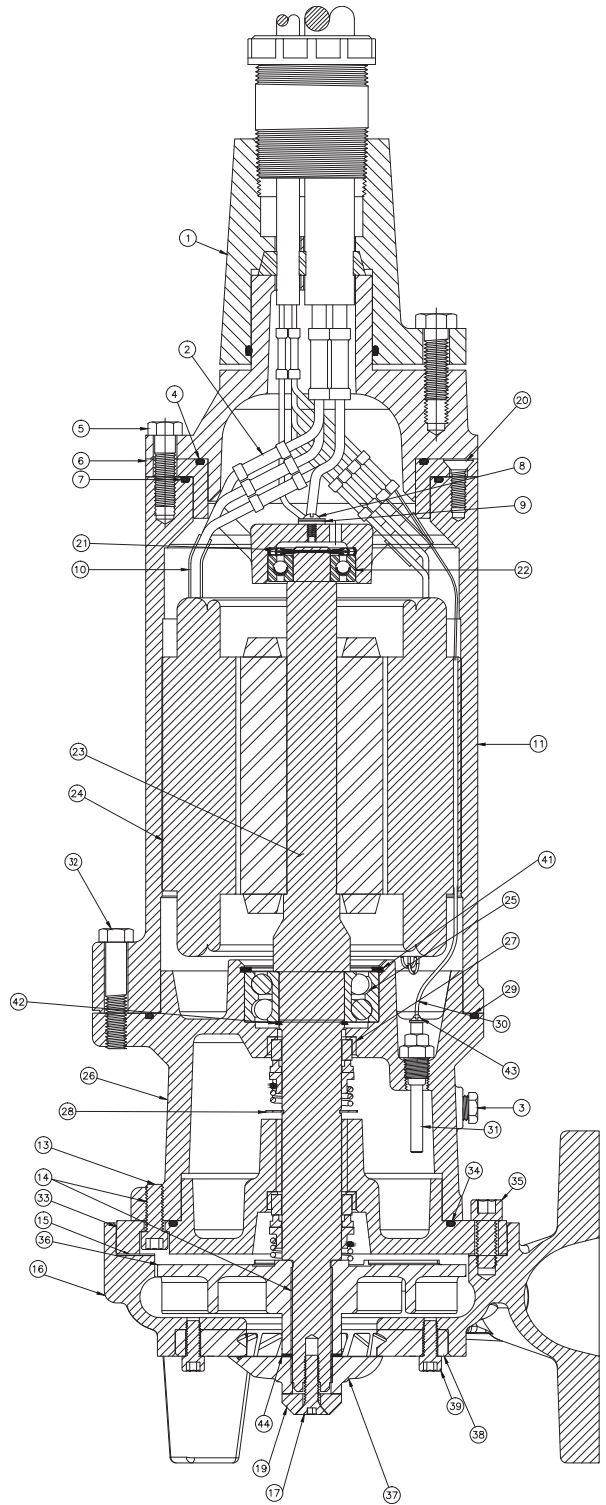

Pump Cat. No.	Rotor w/Shaft	Stator Only	Stator w/Housing
VH30-21	28208C101	22574C210	22571D245K
VH30-03	28208C100	22574C211	22571D250K
VH30-23	28208C100	22574C212	22571D255K
VH30-43	28208C100	22574C213	22571D255K
VH30-53	28208C100	22574C214	22571D265K
VH50-21	28208C103	22574C200	22571D220K
VH50-03	28208C102	22574C201	22571D225K
VH50-23	28208C102	22574C202	22571D231K
VH50-43	28208C102	22574C203	22571D231K
VH50-53	28208C102	22574C204	22571D240K
VH75-03	28208C102	22574C201	22571D225K
VH75-23	28208C102	22574C202	22571D231K
VH75-43	28208C102	22574C203	22571D231K
VH75-53	28208C102	22574C204	22571D240K

**THIS PAGE INTENTIONALLY LEFT BLANK**

**THIS PAGE INTENTIONALLY LEFT BLANK**

## STANDARD LIMITED WARRANTY

Pentair Myers® warrants its products against defects in material and workmanship for a period of 12 months from the date of shipment from Pentair Myers or 18 months from the manufacturing date, whichever occurs first – provided that such products are used in compliance with the requirements of the Pentair Myers catalog and technical manuals for use in pumping raw sewage, municipal wastewater or similar, abrasive-free, noncorrosive liquids.

During the warranty period and subject to the conditions set forth, Pentair Myers, at its discretion, will repair or replace to the original user, the parts that prove defective in materials and workmanship. Pentair Myers reserves the right to change or improve its products or any portions thereof without being obligated to provide such a change or improvement for prior sold and/or shipped units.

Start-up reports and electrical schematics may be required to support warranty claims. Submit at the time of start-up through the Pentair Myers website: <http://forms.pentairliterature.com/startupform/startupform.asp?type=m>. Warranty is effective only if Pentair Myers authorized control panels are used. All seal fail and heat sensing devices must be hooked up, functional and monitored or this warranty will be void. Pentair Myers will cover only the lower seal and labor thereof for all dual seal pumps. Under no circumstance will Pentair Myers be responsible for the cost of field labor, travel expenses, rented equipment, removal/reinstallation costs or freight expenses to and from the factory or an authorized Pentair Myers service facility.

This limited warranty will not apply: (a) to defects or malfunctions resulting from failure to properly install, operate or maintain the unit in accordance with the printed instructions provided; (b) to failures resulting from abuse, accident or negligence; (c) to normal maintenance services and parts used in connection with such service; (d) to units that are not installed in accordance with applicable local codes, ordinances and good trade practices; (e) if the unit is moved from its original installation location; (f) if unit is used for purposes other than for what it is designed and manufactured; (g) to any unit that has been repaired or altered by anyone other than Pentair Myers or an authorized Pentair Myers service provider; (h) to any unit that has been repaired using non factory specified/OEM parts.

Warranty Exclusions: PENTAIR MYERS MAKES NO EXPRESS OR IMPLIED WARRANTIES THAT EXTEND BEYOND THE DESCRIPTION ON THE FACE HEREOF. PENTAIR MYERS SPECIFICALLY DISCLAIMS THE IMPLIED WARRANTIES OF MERCHANTABILITY AND FITNESS FOR ANY PARTICULAR PURPOSE.

Liability Limitation: IN NO EVENT SHALL PENTAIR MYERS BE LIABLE OR RESPONSIBLE FOR CONSEQUENTIAL, INCIDENTAL OR SPECIAL DAMAGES RESULTING FROM OR RELATED IN ANY MANNER TO ANY PENTAIR MYERS PRODUCT OR PARTS THEREOF. PERSONAL INJURY AND/OR PROPERTY DAMAGE MAY RESULT FROM IMPROPER INSTALLATION. PENTAIR MYERS DISCLAIMS ALL LIABILITY, INCLUDING LIABILITY UNDER THIS WARRANTY, FOR IMPROPER INSTALLATION. PENTAIR MYERS RECOMMENDS INSTALLATION BY PROFESSIONALS.

Some states do not permit some or all of the above warranty limitations or the exclusion or limitation of incidental or consequential damages and therefore such limitations may not apply to you. No warranties or representations at any time made by any representatives of Pentair Myers shall vary or expand the provision hereof.



### MYERS®

1101 MYERS PARKWAY  
ASHLAND, OHIO 44805  
PH: 855-274-8947  
WWW.FEMYERS.COM

490 PINEBUSH ROAD, UNIT 4  
CAMBRIDGE, ONTARIO, CANADA N1T 0A5  
PH: 800-363-7867  
WWW.FEMYERS.COM