

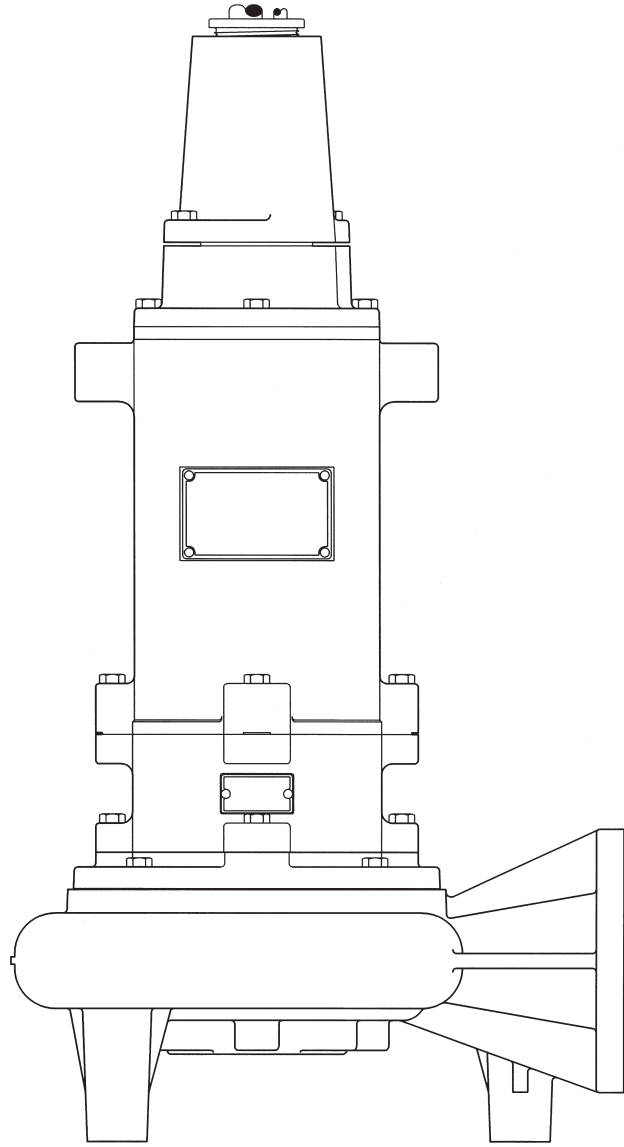

MYERS®



MODELS 4RH/4RHX*, 4VHA/4VHAX*,
4VH/4VHX*, 4VHS/4VHSX* and 6VH/6VHX*

*Used in Hazardous Locations Class I, Division 1, Groups C & D

SUBMERSIBLE SOLIDS HANDLING PUMPS

INSTALLATION AND SERVICE MANUAL

For use with products built with USEM motor.



NOTE! To the installer: Please make sure you provide this manual to the owner of the equipment or to the responsible party who maintains the system.

CAUTION!

Read these safety warnings first before installing, servicing, or operating any pump.

CALIFORNIA PROPOSITION 65 WARNING:

▲ WARNING This product and related accessories contain chemicals known to the State of California to cause cancer, birth defects or other reproductive harm.

GENERAL

1. Most accidents can be avoided by using **COMMON SENSE**.
2. Read the operation and maintenance instruction manual supplied with the pump.
3. Do not wear loose clothing that can become entangled in the impeller or other moving parts.
4. This pump is designed to handle materials that could cause illness or disease through direct exposure.
Wear adequate protective clothing when working on the pump or piping.

ELECTRICAL

5. To reduce the risk of electrical shock, pump must be properly grounded in accordance with the National Electric Code and all applicable state and local codes and ordinances.
6. To reduce risk of electrical shock, disconnect the pump from the power source before handling or servicing.
7. Any wiring to be done on pumps should be done by a qualified electrician.
8. Never operate a pump with a power cord that has frayed or brittle insulation.
9. Never let cords or plugs lie in water.
10. Never handle connected power cords with wet hands.

PUMPS

11. Pump builds up heat and pressure during operation; allow time for pump to cool before handling or servicing.
12. Only qualified personnel should install, operate or repair pump.
13. Keep clear of suction and discharge openings. **DO NOT** insert fingers in pump with power connected.
14. Do not pump hazardous material not recommended for pump (flammable, caustic, etc.).

15. Make sure lifting handles are securely fastened each time before lifting.
16. Do not lift pump by the power cord.
17. Do not exceed manufacturer's recommendation for maximum performance, as this could cause the motor to overheat.
18. Secure the pump in its operating position so it cannot tip over, fall or slide.
19. Keep hands and feet away from impeller when power is connected.
20. Submersible solids handling pumps are not approved for use in swimming pools, recreational water installations, decorative fountains or any installation where human contact with the pumped fluid is common.
21. Do not operate pump without safety devices in place.

IMPORTANT! Myers is not responsible for losses, injury or death resulting from a failure to observe these safety precautions, misuse or abuse of pumps or equipment.

GENERAL INFORMATION:

Pump Models: These instructions cover the installation and service of the Myers pumps as listed on the front cover. The hazardous location models are Factory Mutual approved and listed hazardous location for hazardous sewage locations Class 1, Division 1, Groups C,D.

Motor HP & Voltages: These pumps are offered in a three phase wiring configuration only. Voltages will vary according to the application.

Electrical Controls: All of these pump models must be used with a control panel. Myers built control panels are designed to supply the correct electrical controls, motor starting equipment and include the circuitry for moisture and heat sensors. It is recommended that a Myers built control panel be used so that all warranties apply.

General Construction: The motor construction is designed to meet Factory Mutual's requirements for Class 1, Division 1, Groups C,D sewage applications. The hazardous location models are certified and nameplated with this approval. The motor chamber and seal chamber are filled with a high dielectric type oil for improved lubrication and heat transfer of the bearings and motor. Since the bearings have been designed for 50,000 hours of life, the oil should never require replacement under normal operating conditions. An air space above the oil level in both the seal and motor chambers is provided to allow for the expansion of the oil when at operating temperature. The power and control lines are sealed and strain relieved by a grommet in the cord cap, and internally through the use of a dielectric potting resin surrounding the electrical wires.

All of the pump fasteners and shafts are made from corrosion resistant stainless steel, while the pump castings are made of ASTM A-48 Class 30 cast iron. The wear ring is brass and all impellers are two vane enclosed solids handling design made from ductile iron.

General Installation: Various configurations and methods of plumbing this series of solids handling pumps may be used; however, for ease of installation and service a Myers 4" rail lift-out system is recommended.

Note: If the hazardous location pumps are used in conjunction with a rail lift-out system, it must be an FM approved non-sparking, hazardous location system. The Myers approved lift-out model is:

SRAX44HH

If these guidelines are not followed, the Factory Mutual approval is void.

Hazardous Location Service: These pumps are to be used for handling sewage, wastewater and storm water only. **Do not** use in other hazardous locations. These pumps must be repaired and serviced only at Myers Authorized Service Centers or at the Myers factory. Any unauthorized field repair voids warranty, hazardous location rating and Factory Mutual approval.

CAUTION: After the pump is installed and sewage has entered the basin there are methane and hydrogen sulfide gases, which are poisonous. Never enter a wet well unless the cover is open for a sufficient period of time to allow fresh air into the basin. Myers recommends using the rail lift-out system so that no service is required inside the basin.

Motor: Each motor is provided with heat sensor thermostats attached directly to the motor windings. The thermostats open if the motor windings see excessive heat and, in turn, open the motor contractor in the control panel, breaking the power to the pump. When the motor is stopped due to an overheated condition, it will not start until the motor has cooled and the heat sensor reset button is manually pushed on the front of the Myers control panel. This circuitry is provided in the Myers control panel designs.

Thermostats are set to open at a temperature of 248°F (120°C). The maximum contact rating is 18 amps at 115 VAC and 12 amps at 230 VAC. Motor winding insulation is good for Class H (356°F, 180°C).

Note: Failure to use proper circuitry and to connect the motor overheat protection in the control panel would negate all warranties and FM approval.

Motor Seal Failure Warning: The seal chamber is oil filled and provided with moisture sensing probes to detect water leakage through the lower shaft seal.

The probes can also detect moisture present in the upper motor housing.

The presence of water energizes a red seal leak warning light at the control panel. This is a warning light only, and does not stop the motor. It indicates a leak has occurred and the pump must be repaired. Normally, this indicates the outboard seal has leaked. Allowing the unit to operate after the warning could cause upper seal leakage along with motor failure.

The resistance across the moisture sensing (seal failure) probes should be checked after a seal leak warning light has lit. This can be done by disconnecting the red and orange control wires from the control panel, and measuring the resistance with an ohmmeter between the wires. If the measured values are below specification, the pump may have a lower seal failure and require service.

On the Myers hazardous location control panels the seal leak test switch tests the seal leak circuit continuity. When pushed the seal leak test bulb should light. If the test bulb does not light it means either the wiring circuitry to the seal leak probes has been broken or the bulb has burned out.

Note: Myers built control panels supply the correct circuitry for moisture and heat sensor connections. Failure to install the correct circuitry with proper connection would negate warranty and FM approval.

Motor Power Cord, Control Cord and Cord Cap Assembly: Each motor power cord has 4 conductors: white, black, red and green. For a three phase motor the red, black and white conductors connect to the three line leads, and the green is connected to a good ground. Interchanging any two line leads will reverse the rotation of the motor.

Note: Rotation should be clockwise when observed from the top of the pump. This can be checked by noting which direction the pump torque is up on initial starting. A properly rotating pump will torque counterclockwise upon start.

The control cable has 5 conductors: black, white, red, orange and green. White and black connect to the heat sensor terminals in the control panels; red and orange connect to the seal failure terminals in the control panel; and the green connects to the ground in the control panel.

The cord cap is epoxy potted. The cord cap provides for a sealed wire connection. This allows the cord cap, with cords, to be removed from the motor. An approved hazardous location junction box is required for hazardous locations. **The control and power cables cannot be spliced!**

Note: Each cable has a green ground wire and must be properly grounded per the National Electric Code and local codes.

Electrical Motor Controls: All electrical controls and motor starting equipment should be as specified in these instructions. Consult factory for any acceptable alternatives. For hazardous locations the controls and control panel must be installed outside the hazardous area, or approved hazardous location controls that are intrinsically safe must be used.

Junction Box: If a junction box is used in a hazardous location, it must be a hazardous location approved type with hazardous location cord connectors. Wires from the junction box must pass through a hazardous location seal connector.

Level Sensing Controls: Intrinsically safe type float controls are recommended for all applications and required for hazardous location service. An intrinsically safe control panel relay will limit the current and voltage to the level controls. A Myers control panel can be supplied with this type circuitry.

The float level controls maintain the basin sewage water level by controlling pump turn-on and turn-off levels.

1. The lower turn-off control should be set so that the pump stops at approximately the top of the pump. Consult the factory for any settings below this point.
2. The upper turn-on control should be set above the lower turn-off control. The exact height between the two controls is determined by the number of pump starts desired and the depth of the basin. A maximum of 10 starts per hour should not be exceeded.
3. The override control is set at a specified height above the upper turn-on control.
4. The alarm control is set about 6" to 12" above the override control.
5. No control should be set above the inlet invert.

Electrical Connections: All electrical wiring must be in accordance with local code and only qualified electricians should make the installations. All wires should be checked for shorts to ground with an ohmmeter or megger after the connections are made. This is important, as one grounded wire can cause failure of the pump, control panel or personal injury.

WARNING: Disconnect pump from power source before servicing or handling pump.

Disassembly

1. With the pump located in a secure place, remove the bolts fastening the seal housing to the volute. The motor and impeller can now be removed as a unit.
2. Lay the unit down on its side. If the lower seal is to be removed, it is recommended that the oil in the seal chamber be drained. This can be done by removing the lower seal chamber plug and draining the oil into a holding container.

3. To remove the impeller: Using a proper wrench, the impeller retaining bolt and washer must be removed. This may require a piece of wood placed between the vanes to keep the impeller from rotating while removing the bolt. Once the bolt has been removed, tap lightly with a hammer around the outside diameter of the impeller to loosen from shaft and key. After removing impeller, the seal retainer needs to be removed to expose seal.

Caution: The impeller is large and heavy and will need to be supported.

4. If the lower seal needs removed, first remove the compression spring that rides between the impeller and the seal assembly. Next take a pair of screwdrivers and remove the compression ring that surrounds the rubber bellows on the rotating portion of the seal assembly. Again using the screwdrivers, pry the remaining portion of the rotating seal assembly off the shaft. The ceramic stationary can be removed by placing a screwdriver between the rubber and the ceramic face and then prying, working around the entire diameter. Note, these parts should be discarded and a new seal assembly installed.
5. If the oil in the seal chamber was drained, examine the contents to determine if the upper seal has been damaged. Signs of grit or other abrasive material may indicate that the upper seal has also been damaged. Pressurizing the motor housing assembly between 7 and 10 psi and observing any drop in pressure will indicate if the upper seal is functioning properly.

Note: Upper seal repairs must be done at a Myers Authorized Service Center or at the Myers factory. Any unauthorized field repair voids warranty and the hazardous location approval on the FM listed pump.
6. The wear ring can be removed from the volute for repair or replacement. First remove the retaining screws from the wear ring. With a soft mallet the wear ring can be tapped out of the volute case.

Reassembly

1. Remove the ceramic portion of the new seal from the package. Brush new dielectric oil around the rubber portion of the stationary assembly and into the pocket in the seal housing. Note, keep the oil off the seal face. Without scratching the seal face, press the ceramic stationary portion into the seal housing using a Myers seal pusher. With clean cloth, lightly wipe the face of the seal surface to make sure it is dirt free. Remove the rotating portion of the seal from the package and lubricate the inside diameter of the rubber bellows and the outside diameter of the shaft. Place the seal over the shaft (make sure the key is removed). Evenly press on the body of the rotational assembly and slide it down the shaft

until the seal faces meet. Once the seal assembly is in position, place the spring over the register on the rotational portion of the seal.

2. Before placing impeller on shaft, the seal spring retainer should be placed on shaft with stepped end toward seal spring. Position the key into the seat in the shaft. Align the impeller onto the shaft, making sure that the seal spring is registered properly onto the back side of the impeller. Insert the bolt and washer assembly into the shaft and tighten to 93 ft.-lbs.
3. Fill the seal chamber with new dielectric oil. An air gap of 10–15% volume must be left for the expansion of the oil when it is at operating temperature.

4. The brass wear ring can be aligned with the retaining holes and tapped into place with a soft mallet. The proper Loctite should be applied to the bolts. Install and tighten.
5. The motor and impeller assembly can be installed into the volute. Make sure that the impeller aligns properly with the volute. Install the volute retaining bolts and tighten.
6. Air tends to trap in the pump case when water rises in the sump or when the pump is lowered into the water after service. To vent off this air, a small hole is drilled into the volute casting. **Be sure this vent hole is clean after any service work on pump.** Air venting is not a problem after initial start.

CHECK LIST IF PUMP DOES NOT OPERATE PROPERLY

Checking for Moisture in Motor: Use an ohmmeter or a megger and set on highest scale. Readings on the large power cord between any of the conductors red, black or white to the green conductor or to the motor housing should be greater than 1,000,000 ohms (1 megohm). Service work should be done only at an authorized service station. Note, readings should be taken with line leads disconnected from the control panel.

Resistance of Windings: Every motor winding has a fixed resistance. The windings must check close to specification values. Verification of the proper wiring of a dual voltage motor can also be checked by measuring the motor winding resistance.

CONDITION

Red light comes on at control box.

PROBABLE CAUSE

This indicates some water has leaked past the lower seal and has entered the seal chamber and made contact with the electrode probe. Pump must be removed for replacement of lower seal. This preventive repair will save an expensive motor.

Overload trips at control box and alarm buzzer or flashing red light comes on due to high water level in basin.

1. Push in on red reset button to reset overload. If overload trips again after short run, pump has some damage and must be removed from basin for checking.
2. Trouble may be from clogged impeller causing motor to overload or could be from failed motor.
3. Trouble may be from faulty component in control box. Always check control box before removing pump.

Yellow run light stays on continuously.

1. Indicates H-O-A switch may be in the hand position.
2. Level control switch may have failed causing pump to continue to operate when water is below lower control.
3. Impeller may be partially clogged causing pump to operate at very reduced capacity.
4. Gate valve or check valve may be clogged causing low pump flow.
5. Pump may be air locked.

CONDITION

PROBABLE CAUSE

Circuit breaker trips.

1. Reset breaker by pushing completely down on handle then back to ON position. If breaker trips again in a few seconds it indicates excessive load probably caused by a short in the motor or control box. Check out instructions given with control box before pulling pump.
2. If this condition happens after an electrical storm, motor or control box may be damaged by lightning.
3. Resistance reading of the motor with lead wires disconnected from the control box can determine if trouble is in motor or control box.

Pump is noisy and pump rate is low.

1. Impeller may be partially clogged with some foreign objects causing noise and overload on the motor.
2. Impeller may be rubbing on wear ring due to bent shaft or misalignment.
3. Pump may be operating too close to shut-off. Check head.

Grease and solids have accumulated around pump and will not pump out of basin.

1. Lower control switch may be set too high.
 2. Run pump on hand operation for several minutes with small amount of water running into basin to clean out solids and grease. This allows pump to break suction and surge which will break up the solids. If level switch is set properly this condition generally will not occur.
 3. Trash and grease may have accumulated around floats causing pump to operate erratically.
-

WET END PARTS

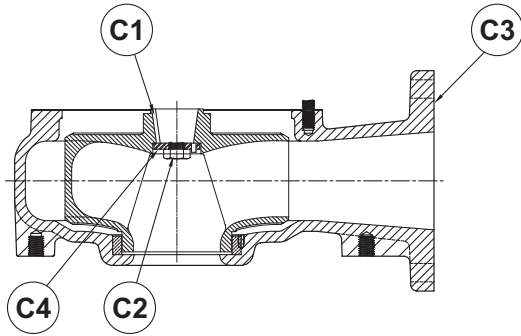

4VHS/4VHSX, 4VH/4VHX, 6VH/6VHX

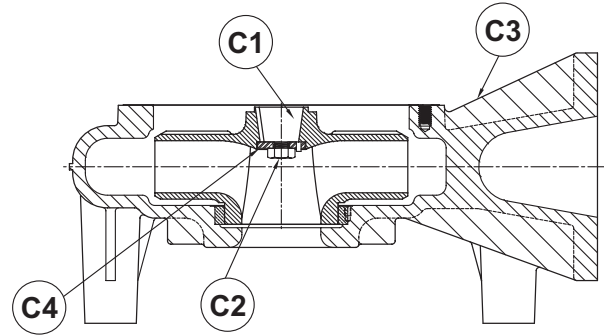

4VHA/4VHAX

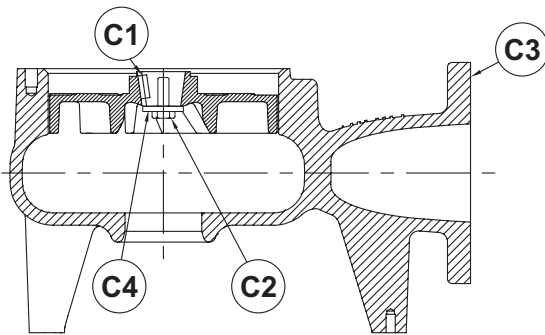

4RH/4RHX – 1150/1750 RPM

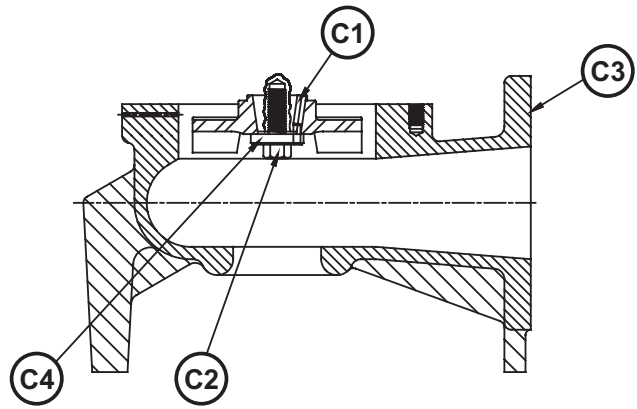

4RH/4RHX – 3450 RPM

WET END PARTS LIST

4VHS/4VHSX, 4VH/4VHX

Ref.	Description	Part Number
C1	KEY-SQUARE SST	05818A067
C2	SCREW-CAP	19105A033
C3	CASE-VOLUTE	22886D000
C4	WASHER-RETAINER	23609A003
Replacement Parts	VOLUTE WEAR RING	22712D001A
Replacement Parts	WEAR RING SCREW	05013A013

4RH/4RHX – 1150/1750 RPM

Ref.	Description	Part Number
C1	KEY-SQUARE SST	05818A067
C2	SCREW-CAP	19105A033
C3	CASE-VOLUTE	070801002
C4	WASHER-RETAINER	23609A003
Replacement Parts	O-RING	001500581

4VHA/4VHAX

Ref.	Description	Part Number
C1	KEY-SQUARE SST	05818A067
C2	SCREW-CAP	19105A033
C3	CASE-VOLUTE	27049F000
C4	WASHER-RETAINER	23609A003
Replacement Parts	VOLUTE WEAR RING	27049F010M
Replacement Parts	WEAR RING SCREW	05013A013

4RH/4RHX – 3450 RPM

Ref.	Description	Part Number
C1	KEY-SQUARE SST	05818A067
C2	SCREW-CAP	19105A033
C3	CASE-VOLUTE	25988D000
C4	WASHER-RETAINER	23609A003
Replacement Parts	VOLUTE WEAR RING	---
Replacement Parts	WEAR RING SCREW	---

6VH/6VHX

Ref.	Description	Part Number
C1	KEY-SQUARE SST	05818A067
C2	SCREW-CAP	19105A033
C3	CASE-VOLUTE	23035E000
C4	WASHER-RETAINER	23609A003
Replacement Parts	VOLUTE WEAR RING	22712D001A
Replacement Parts	WEAR RING SCREW	05013A013

MOTOR END PARTS

Cap Screw	Torque Value
3/8-16	20 ft.-lbs.
1/2-13	43 ft.-lbs.
5/8-11	93 ft.-lbs.
3/4-10	128 ft.-lbs.
7/8-14	193 ft.-lbs.

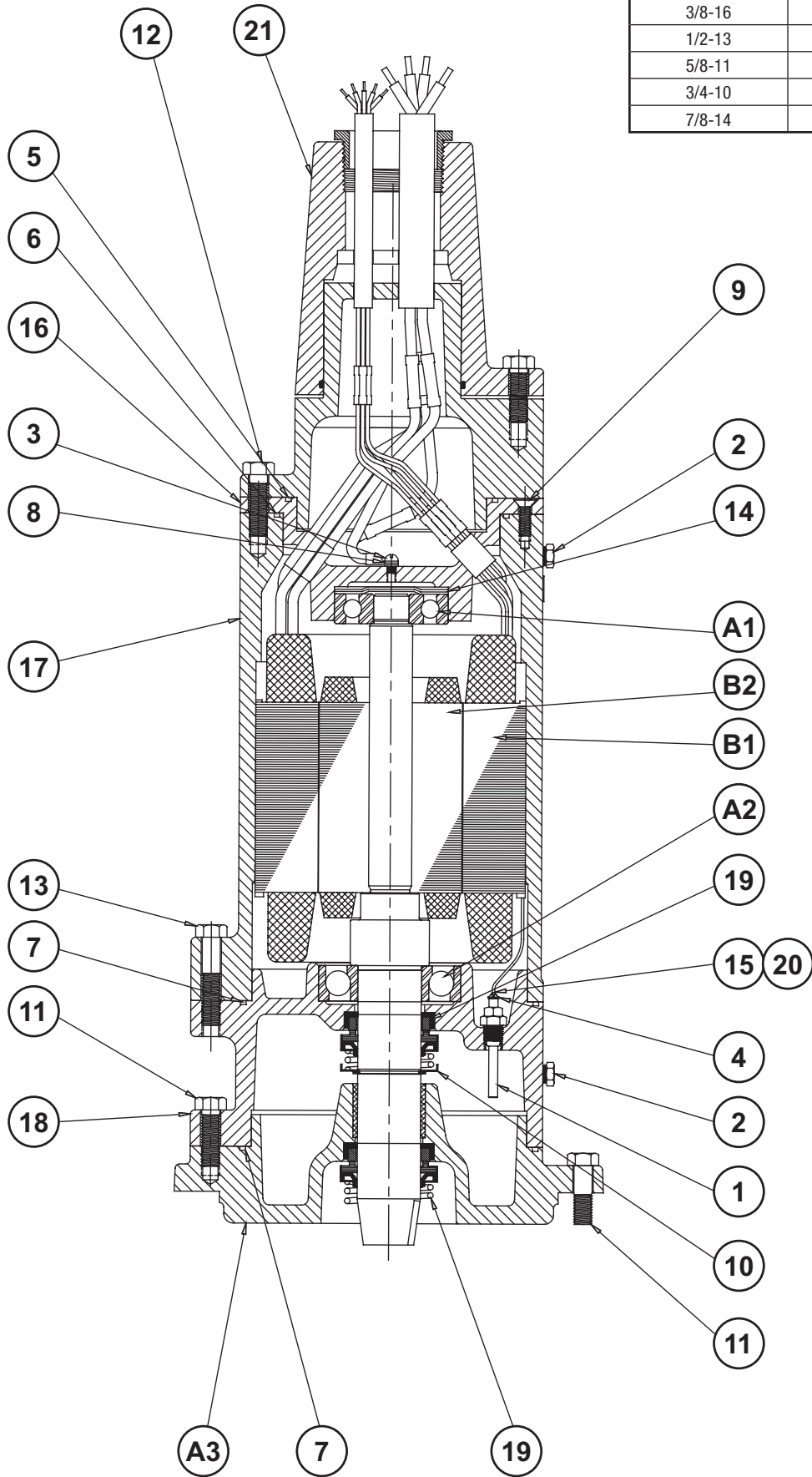

COMMON PARTS LIST

Ref. No.	Part No.	Description	Qty.
1	25343A100	PROBE-SEAL	2
2	05022A092	PLUG-PIPE 1/4" HEX HD.	2
3	05028A002	SCREW-MACH. ST PL 1/4-20	1
4	05434A025	SCREW-MACH. ST Z&D #6-32	2
5	05876A119	O-RING	1
6	05876A120	O-RING	1
7	05876A121	O-RING	2
8	06107A016	WASHER-LOCK	1
9	07597A017	SCREW-MACH. FLT HEX HEAD SOCKET	2
10	12588A017	RING-RET EXTERNAL	1
11	19103A043	SCREW-CAP HEX SST	8
12	19103A045	SCREW-CAP HEX SST	4
13	19103A048	SCREW-CAP HEX SST	4
14	19331A007	WASHER-SPRING WAVE	2
15	22578A100	WIRE-ELECTRODE	2

Ref. No.	Part No.	Description	Qty.
16	22873C000	CAP-UPPER BEARING	1
17	22874D001	HOUSING-MOTOR	1
18	22882D010	HOUSING-SEAL	1
19	22883A000	SEAL TYPE 21	2
20	22912A000	RESISTOR-33000 OHM 1/2 WATT (Hazardous location only)	1
21	22872C032	35' CORD ASSEMBLY 10-4	1
	22872C035	35' CORD ASSEMBLY 8-4 SOOW	1
	22872C036	35' CORD ASSEMBLY 8-4 W	1
	22872C034	35' CORD ASSEMBLY 6-4	1
	22872C632	35' HAZARDOUS LOCATION CORD 10-4	1
	22872C635	35' HAZARDOUS LOCATION CORD 8-4 SOOW	1
	22872C636	35' HAZARDOUS LOCATION CORD 8-4 W	1
22872C634	35' HAZARDOUS LOCATION CORD 6-4	1	

MODEL SPECIFIC PARTS LIST

Ref.	Description	4VHA/ 4VHAX, 4VHS/ 4VHSX, 4VH/ 4VHX, 6VH/ 6VHX	4RH/ 4RHX
A1	BEARING-BALL UPPER	08565A032 (1)	08565A032
A2	BEARING-BALL LOWER	08565A026 (1)	25833A002
A3	HOUSING-LOWER SEAL	22884D000 (1)	25991D000
	RING-RET EXTERNAL	12558A024 (1)	---
	WASHER	05030A214 (1)	---
	GASKET-VELLUMOID	05231A080 (1)	---

WIRING DIAGRAMS

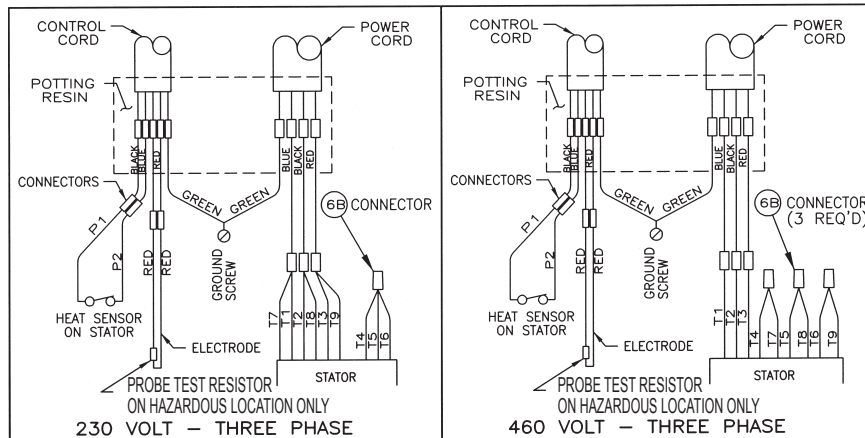
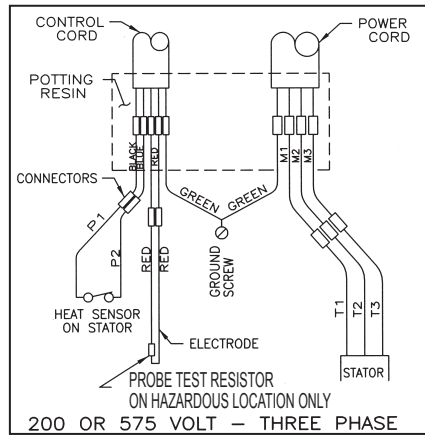

Pump Catalog Model		B1	B1	B2	13 Stator Only	Impeller
		Stator w/Housing – Standard	Stator w/Housing – Hazardous Location	Rotor w/ Shaft		
4VH30M6-03	6VH30M6-03	22874D322K	22874D624K	22875C203X	142972031	22885D560
4VH30M6-23	6VH30M6-23	22874D327K	22874D627K	22875C203X	142970031	22885D560
4VH30M6-43	6VH30M6-43	22874D327K	22874D627K	22875C203X	142970031	22885D560
4VH30M6-53	6VH30M6-53	22874D337K	22874D637K	22875C203X	142976031	22885D560
4VH50M6-03	6VH50M6-03	22874D323K	22874D626K	22875C203X	142972031	22885D553
4VH50M6-23	6VH50M6-23	22874D328K	22874D628K	22875C203X	142970031	22885D553
4VH50M6-43	6VH50M6-43	22874D328K	22874D628K	22875C203X	142970031	22885D553
4VH50M6-53	6VH50M6-53	22874D338K	22874D639K	22875C203X	142976031	22885D553
4VH50M4-01	6VH50M4-01	22874D221K	22874D621K	22875C201X	141422011	22885D568
4VH50M4-21	6VH50M4-21	22874D222K	22874D622K	22875C201X	141420011	22885D568
4VH50M4-03	6VH50M4-03	22874D242K	22874D642K	22875C203X	141402031	22885D568
4VH50M4-23	6VH50M4-23	22874D247K	22874D647K	22875C203X	141400031	22885D568
4VH50M4-43	6VH50M4-43	22874D247K	22874D647K	22875C203X	141400031	22885D568
4VH50M4-53	6VH50M4-53	22874D257K	22874D657K	22875C203X	141406031	22885D568
4VH75M4-21	6VH75M4-21	22874D238K	22874D638K	22875C212X	141440011	22885D564
4VH75M4-03	6VH75M4-03	22874D243K	22874D643K	22875C203X	141402031	22885D564
4VH75M4-23	6VH75M4-23	22874D248K	22874D648K	22875C203X	141400031	22885D564
4VH75M4-43	6VH75M4-43	22874D248K	22874D648K	22875C203X	141400031	22885D564
4VH75M4-53	6VH75M4-53	22874D258K	22874D658K	22875C203X	141406031	22885D564
4VH100M4-03	6VH100M4-03	22874D262K	22874D662K	22875C204X	141412031	22885D560
4VH100M4-23	6VH100M4-23	22874D267K	22874D667K	22875C204X	141410031	22885D560
4VH100M4-43	6VH100M4-43	22874D267K	22874D667K	22875C204X	141410031	22885D560
4VH100M4-53	6VH100M4-53	22874D277K	22874D677K	22875C204X	141416031	22885D560
4VH150M4-03	6VH150M4-03	22874D282K	22874D682K	22875C204X	141432031	22885D556
4VH150M4-23	6VH150M4-23	22874D287K	22874D687K	22875C204X	141430031	22885D556
4VH150M4-43	6VH150M4-43	22874D287K	22874D687K	22875C204X	141430031	22885D556
4VH150M4-53	6VH150M4-53	22874D297K	22874D697K	22875C204X	141436031	22885D556
4VH200M4-03	6VH200M4-03	22874D283K	22874D683K	22875C204X	141432031	22885D553
4VH200M4-23	6VH200M4-23	22874D288K	22874D688K	22875C204X	141430031	22885D553
4VH200M4-43	6VH200M4-43	22874D288K	22874D688K	22875C204X	141430031	22885D553
4VH200M4-53	6VH200M4-53	22874D298K	22874D698K	22875C204X	141436031	22885D553
4VHS75M4-21	-	22874D238K	22874D638K	22875C212X	141440011	23498D555
4VHS75M4-03	-	22874D243K	22874D643K	22875C203X	141402031	23498D555
4VHS75M4-23	-	22874D248K	22874D648K	22875C203X	141400031	23498D555
4VHS75M4-43	-	22874D248K	22874D648K	22875C203X	141400031	23498D555
4VHS75M4-53	-	22874D258K	22874D658K	22875C203X	141406031	23498D555
4VHS100M4-03	-	22874D262K	22874D662K	22875C204X	141412031	23498D551
4VHS100M4-23	-	22874D267K	22874D667K	22875C204X	141410031	23498D551
4VHS100M4-43	-	22874D267K	22874D667K	22875C204X	141410031	23498D551
4VHS100M4-53	-	22874D277K	22874D677K	22875C204X	141416031	23498D551
4VHA50M4-03	-	22874D242K	22874D642K	22875C203	141402031	27048D574
4VHA50M4-23	-	22874D247K	22874D647K	22875C203	141400031	27048D574
4VHA50M4-43	-	22874D247K	22874D647K	22875C203	141400031	27048D574
4VHA50M4-53	-	22874D257K	22874D657K	22875C203	141406031	27048D574
4VHA75M4-03	-	22874D243K	22874D643K	22875C203	141402031	27048D566
4VHA75M4-23	-	22874D248K	22874D648K	22875C203	141400031	27048D566
4VHA75M4-43	-	22874D248K	22874D648K	22875C203	141400031	27048D566
4VHA75M4-53	-	22874D258K	22874D658K	22875C203	141406031	27048D566
4VHA100M4-03	-	22874D262K	22874D662K	22875C204	141412031	27048D564
4VHA100M4-23	-	22874D267K	22874D667K	22875C204	141410031	27048D564
4VHA100M4-43	-	22874D267K	22874D667K	22875C204	141410031	27048D564
4VHA100M4-53	-	22874D277K	22874D677K	22875C204	141416031	27048D564
4VHA150M4-03	-	22874D282K	22874D682K	22875C204	141432031	27048D556
4VHA150M4-23	-	22874D287K	22874D687K	22875C204	141430031	27048D556
4VHA150M4-43	-	22874D287K	22874D687K	22875C204	141430031	27048D556
4VHA150M4-53	-	22874D297K	22874D697K	22875C204	141436031	27048D556

NOTE: Consult Factory for straight shaft impeller part number.

Pump Catalog Model		B1	B1	B2	13 Stator Only	Impeller
		Stator w/Housing – Standard	Stator w/Housing – Hazardous Location	Rotor w/ Shaft		
4RH30M6-03	4RHX30M6-03	22874D322K	22874D624K	22875C203X	142972031	070811032
4RH30M6-23	4RHX30M6-23	22874D327K	22874D627K	22875C203X	142970031	070811032
4RH30M6-43	4RHX30M6-43	22874D327K	22874D627K	22875C203X	142970031	070811032
4RH30M6-53	4RHX30M6-53	22874D337K	22874D637K	22875C203X	142976031	070811032
4RH50M6-03	4RHX50M6-03	22874D323K	22874D626K	22875C203X	142972031	070811002
4RH50M6-23	4RHX50M6-23	22874D328K	22874D628K	22875C203X	142970031	070811002
4RH50M6-43	4RHX50M6-43	22874D328K	22874D628K	22875C203X	142970031	070811002
4RH50M6-53	4RHX50M6-53	22874D338K	22874D639K	22875C203X	142976031	070811002
4RH50M4-01	4RHX50M4-01	22874D221K	22874D621K	22875C201X	141422011	070811082
4RH50M4-21	4RHX50M4-21	22874D222K	22874D622K	22875C201X	141420011	070811082
4RH50M4-03	4RHX50M4-03	22874D242K	22874D642K	22875C203X	141402031	070811082
4RH50M4-23	4RHX50M4-23	22874D247K	22874D647K	22875C203X	141400031	070811082
4RH50M4-43	4RHX50M4-43	22874D247K	22874D647K	22875C203X	141400031	070811082
4RH50M4-53	4RHX50M4-53	22874D257K	22874D657K	22875C203X	141406031	070811082
4RH75M4-21	4RHX75M4-21	22874D238K	22874D638K	22875C212X	141440011	070811052
4RH75M4-03	4RHX75M4-03	22874D243K	22874D643K	22875C203X	141402031	070811052
4RH75M4-23	4RHX75M4-23	22874D248K	22874D648K	22875C203X	141400031	070811052
4RH75M4-43	4RHX75M4-43	22874D248K	22874D648K	22875C203X	141400031	070811052
4RH75M4-53	4RHX75M4-53	22874D258K	22874D658K	22875C203X	141406031	070811052
4RH100M4-03	4RHX100M4-03	22874D262K	22874D662K	22875C204X	141412031	070811022
4RH100M4-23	4RHX100M4-23	22874D267K	22874D667K	22875C204X	141410031	070811022
4RH100M4-43	4RHX100M4-43	22874D267K	22874D667K	22875C204X	141410031	070811022
4RH100M4-53	4RHX100M4-53	22874D277K	22874D677K	22875C204X	141416031	070811022
4RH150M4-03	4RHX150M4-03	22874D282K	22874D682K	22875C204X	141432031	070811002
4RH150M4-23	4RHX150M4-23	22874D287K	22874D687K	22875C204X	141430031	070811002
4RH150M4-43	4RHX150M4-43	22874D287K	22874D687K	22875C204X	141430031	070811002
4RH150M4-53	4RHX150M4-53	22874D297K	22874D697K	22875C204X	141436031	070811002
4RH75M2-03	4RHX75M2-03	22874D357K	22874D757K	26123C105X	141452031	25987B502
4RH75M2-23	4RHX75M2-23	22874D362K	22874D762K	26123C105X	141450031	25987B502
4RH75M2-43	4RHX75M2-43	22874D362K	22874D762K	26123C105X	141450031	25987B502
4RH75M2-53	4RHX75M2-53	22874D367K	22874D767K	26123C105X	141456031	25987B502
4RH100M2-03	4RHX100M2-03	22874D358K	22874D758K	26123C105X	141452031	25987B504
4RH100M2-23	4RHX100M2-23	22874D363K	22874D763K	26123C105X	141450031	25987B504
4RH100M2-43	4RHX100M2-43	22874D363K	22874D763K	26123C105X	141450031	25987B504
4RH100M2-53	4RHX100M2-53	22874D368K	22874D768K	26123C105X	141456031	25987B504
4RH150M2-03	4RHX150M2-03	22874D372K	22874D772K	26123C105X	141462031	25987B506
4RH150M2-23	4RHX150M2-23	22874D377K	22874D777K	26123C105X	141460031	25987B506
4RH150M2-43	4RHX150M2-43	22874D377K	22874D777K	26123C105X	141460031	25987B506
4RH150M2-53	4RHX150M2-53	22874D382K	22874D782K	26123C105X	141466031	25987B506
4RH200M2-23	4RHX200M2-23	22874D378K	22874D778K	26123C105X	141460031	25987B514
4RH200M2-43	4RHX200M2-43	22874D378K	22874D778K	26123C105X	141460031	25987B514
4RH200M2-53	4RHX200M2-53	22874D383K	22874D783K	26123C105X	141466031	25987B514

NOTE: Consult Factory for straight shaft impeller part number.

STANDARD LIMITED WARRANTY

Pentair Myers® warrants its products against defects in material and workmanship for a period of 12 months from the date of shipment from Pentair Myers or 18 months from the manufacturing date, whichever occurs first – provided that such products are used in compliance with the requirements of the Pentair Myers catalog and technical manuals for use in pumping raw sewage, municipal wastewater or similar, abrasive-free, noncorrosive liquids.

During the warranty period and subject to the conditions set forth, Pentair Myers, at its discretion, will repair or replace to the original user, the parts that prove defective in materials and workmanship. Pentair Myers reserves the right to change or improve its products or any portions thereof without being obligated to provide such a change or improvement for prior sold and/or shipped units.

Start-up reports and electrical schematics may be required to support warranty claims. Submit at the time of start-up through the Pentair Myers website: <http://forms.pentairliterature.com/startupform/startupform.asp?type=m>. Warranty is effective only if Pentair Myers authorized control panels are used. All seal fail and heat sensing devices must be hooked up, functional and monitored or this warranty will be void. Pentair Myers will cover only the lower seal and labor thereof for all dual seal pumps. Under no circumstance will Pentair Myers be responsible for the cost of field labor, travel expenses, rented equipment, removal/reinstallation costs or freight expenses to and from the factory or an authorized Pentair Myers service facility.

This limited warranty will not apply: (a) to defects or malfunctions resulting from failure to properly install, operate or maintain the unit in accordance with the printed instructions provided; (b) to failures resulting from abuse, accident or negligence; (c) to normal maintenance services and parts used in connection with such service; (d) to units that are not installed in accordance with applicable local codes, ordinances and good trade practices; (e) if the unit is moved from its original installation location; (f) if unit is used for purposes other than for what it is designed and manufactured; (g) to any unit that has been repaired or altered by anyone other than Pentair Myers or an authorized Pentair Myers service provider; (h) to any unit that has been repaired using non factory specified/OEM parts.

Warranty Exclusions: PENTAIR MYERS MAKES NO EXPRESS OR IMPLIED WARRANTIES THAT EXTEND BEYOND THE DESCRIPTION ON THE FACE HEREOF. PENTAIR MYERS SPECIFICALLY DISCLAIMS THE IMPLIED WARRANTIES OF MERCHANTABILITY AND FITNESS FOR ANY PARTICULAR PURPOSE.

Liability Limitation: IN NO EVENT SHALL PENTAIR MYERS BE LIABLE OR RESPONSIBLE FOR CONSEQUENTIAL, INCIDENTAL OR SPECIAL DAMAGES RESULTING FROM OR RELATED IN ANY MANNER TO ANY PENTAIR MYERS PRODUCT OR PARTS THEREOF. PERSONAL INJURY AND/OR PROPERTY DAMAGE MAY RESULT FROM IMPROPER INSTALLATION. PENTAIR MYERS DISCLAIMS ALL LIABILITY, INCLUDING LIABILITY UNDER THIS WARRANTY, FOR IMPROPER INSTALLATION. PENTAIR MYERS RECOMMENDS INSTALLATION BY PROFESSIONALS.

Some states do not permit some or all of the above warranty limitations or the exclusion or limitation of incidental or consequential damages and therefore such limitations may not apply to you. No warranties or representations at any time made by any representatives of Pentair Myers shall vary or expand the provision hereof.



MYERS®

1101 MYERS PARKWAY
ASHLAND, OHIO, USA 44805
419-289-1144

490 PINEBUSH ROAD, UNIT #4
CAMBRIDGE, ONTARIO, CANADA N1T 0A5
800-363-PUMP

WWW.FEMYERS.COM

Warranty Rev. 12/13