



**MYERS<sup>®</sup>**  
**MODELS 4V AND 4VX**  
**SOLIDS HANDLING**  
**WASTEWATER PUMPS**

**STANDARD (4V) AND HAZARDOUS LOCATION (4VX) CONSTRUCTION**



# MYERS® MODELS 4V AND 4VX

## Solids Handling Wastewater Pumps

### The Right Choice

The 4V and 4VX (hazardous location) submersible wastewater pumps pass a full 3" spherical solid and are the ideal choice when selecting a pump for your next application. Myers® rounded port, 2-vane, enclosed impellers prevent solids from binding or clogging and offer high operating efficiencies to cut your pumping costs. The 4V series modified constant velocity volute case provides smooth operation over an extended portion of the performance curve for longer seal and bearing life. For use in municipal lift stations, treatment plants and industrial waste applications. Myers offers a complete line of wastewater pumps, lift-out rail assemblies, controls and accessories to meet your needs.



Product Capabilities		
Capacities To	715 gpm	45.1 lps
Heads To	59 ft.	17.9 m
Solids Handling (dia.)	3 in.	76 mm
Liquid Handling	raw unscreened sewage, effluent, storm water	
Intermittent Liquid Temp.	up to 140°F	up to 60°C
Winding Insulation Temp. (Class F)	311°F	155°C
Motor Electrical Data	1750 RPM 3-5 HP, 230V, 1Ø, 60 Hz 3-10 HP, 208/230/460/575V 3Ø, 60 Hz 1150 RPM 1-2 HP, 208/230V, 1Ø, 60 Hz and 208/230/460/575V 3Ø, 60 Hz	
(Single phase motors are capacitor start type. Myers control panels or capacitor kits are required for proper operation and warranty.)		
Std. Third Party Approvals	CSA	
Optional Approvals	CSA & FM Class 1, Group D (4VX only)	
Acceptable pH Range	6 - 9	
Specific Gravity	.9 - 1.1	
Viscosity	28 - 35 SSU	
Discharge, Flanged	4 in.	101.6 mm
Ceterline (Horizontal)	125 lb. ANSI	

Construction Materials	
Motor Housing, Seal Housing, Cord Cap and Volute Case	cast iron, Class 30, ASTM A48
Enclosed 2-Vane Impeller	ductile iron, Class 65 ASTM A536
Power Cord	SOOW, W
Control Cord	SOOW
Mechanical Seals	double tandem, type 21
Standard	carbon and ceramic
Optional	lower tungsten, carbide
Pump, Motor Shaft	416 SST
Fasteners	300 Series SST
Volute Wear Ring	brass

Note: Consult factory for applications outside these recommendations.

# Pump Features and Applications

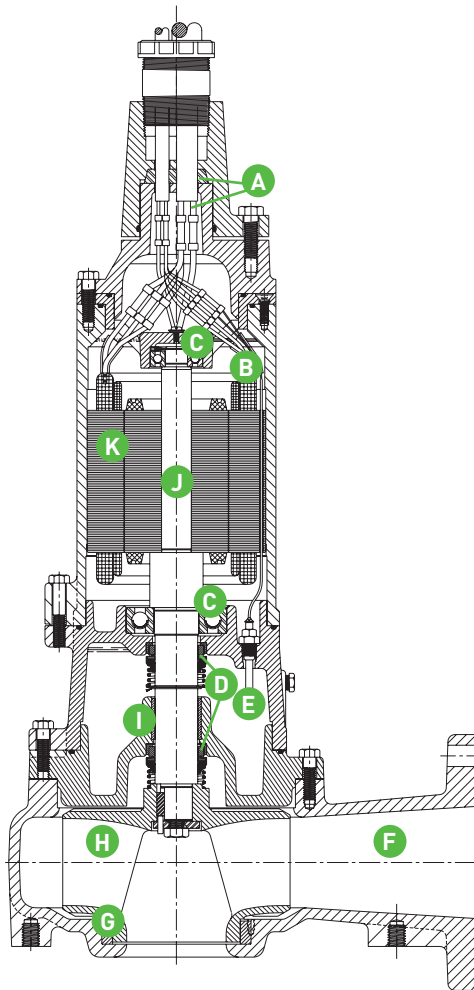

## A. Cable Entry System

Provides double seal protection.  
Cable jacket sealed by compression grommet.  
Individual wires sealed by epoxy potting.

## B. Heat Sensor on Motor Winding

Protect motor from burnout due to excessive heat from any overload condition. Automatically resets when motor has cooled.

## C. Ball Bearings

Upper and lower ball bearings support shaft and rotor and take axial and radial loads.

## D. Shaft Seals

Double tandem mechanical shaft seals protect motor. Oil-filled seal chamber provides continuous lubrication.

## E. Seal Leak Probe

Detects water in seal housing. Activates warning light in control panel. (Test resistor on FM listed models.)

## F. Volute Case

Modified constant velocity volute handles 3" solids. 4" ANSI 125 lb. flange.

## G. Brass Wear Ring

Prevents rust buildup and reduces leakage and wear. Replaceable to restore original running clearance and pump efficiencies.

## H. High Efficiency Impeller

2-vane with rounded port. (Optional single vane.) Handles 3" solids. Pump-out vanes help keep trash from seal; reduce pressure at seal faces.

## I. Sleeve Bearing

Takes radial shock load; provides flame path.

## J. Heavy 416 SST Shaft

Corrosion resistant.

## K. Motor Stator

Press fit for optimal alignment and heat transfer. Oil-filled for continuous lubrication of bearings and seals.

High efficiency hydraulic design cuts pumping costs and extends life of fluid end components.

- Two-vane, rounded port, enclosed type impellers handle 3" solids with ease at high operating efficiencies.
- Modified constant velocity volute offers quiet operation, low radial loads over extended portion of performance curve.

Durable motor will deliver many years of reliable service.

- Oil-filled motor for maximum heat dissipation and constant bearing lubrication.
- Heat sensor thermostats embedded in windings protect motor from overheat conditions.
- Seal leak probe in seal chamber warns of moisture entry; helps prevent costly motor burnout.
- Double tandem shaft seals prevent sewage from entering motor.
- Power and control cables are double sealed with epoxy and compression grommet.

Available With Optional CSA & FM Approval For Use In Class 1, Group D Hazardous Locations (4VX Only).

# Performance Data

1150 RPM

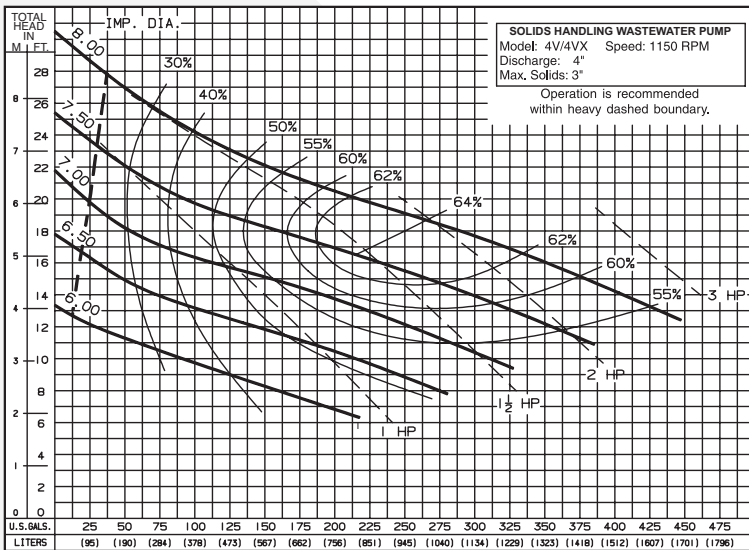

Available Models		Motor Electrical Data											
Standard	Hazardous Location	HP	Volts	Phase	Hertz	Start Amps	Full Load Amps	Service Factor Amps	Full Load kW	Start KVA	Full Load KVA	NEC Code Letter	Service Factor
4V10M6-21	4VX10M6-21	1	230	1	60	42	9	10.8	1.4	9.7	2.1	L	1.2
4V10M6-03	4VX10M6-03	1	208	3	60	27	7.4	8.9	2.3	9.7	2.7	L	1.2
4V10M6-23	4VX10M6-23	1	230	3	60	23	6.4	7.8	2.2	9.2	2.5	L	1.2
4V10M6-43	4VX10M6-43	1	460	3	60	11	3.2	3.9	2.2	8.8	2.5	K	1.2
4V10M6-53	4VX10M6-53	1	575	3	60	7	2.6	3.1	2.2	7.0	2.6	H	1.2
4V15M6-21	4VX15M6-21	1.5	230	1	60	47	11	13.2	1.9	10.8	2.5	J	1.2
4V15M6-03	4VX15M6-03	1.5	208	3	60	30	9.8	11.8	3.1	10.8	3.5	J	1.2
4V15M6-23	4VX15M6-23	1.5	230	3	60	26	8.5	10.2	3.0	10.3	3.4	H	1.2
4V15M6-43	4VX15M6-43	1.5	460	3	60	13	4.2	5.1	3.0	10.3	3.3	H	1.2
4V15M6-53	4VX15M6-53	1.5	575	3	60	10	3.3	4	3.1	9.9	3.3	H	1.2
4V20M6-21	4VX20M6-21	2	230	1	60	71	18	21	3.0	16.3	4.1	K	1.2
4V20M6-03	4VX20M6-03	2	208	3	60	43	12	14.5	3.8	15.5	4.3	J	1.2
4V20M6-23	4VX20M6-23	2	230	3	60	42	10.5	12.6	3.8	16.7	4.4	K	1.2
4V20M6-43	4VX20M6-43	2	460	3	60	21	5.2	6.3	3.8	16.7	4.4	K	1.2
4V20M6-53	4VX20M6-53	2	575	3	60	17	4.2	5	3.8	16.9	4.4	K	1.2
4V30M6-21		3	230	1	60	71	21	21	3.7	16.3	4.8	F	1.0
4V30M6-03		3	208	3	60	43	16.8	16.8	5.3	15.5	6.0	F	1.0
4V30M6-23		3	230	3	60	42	16	16	4.8	16.7	5.6	F	1.0
4V30M6-43		3	460	3	60	21	7	7	4.8	16.7	5.6	F	1.0
4V30M6-53		3	575	3	60	17	5.6	5.6	5.0	16.9	5.6	G	1.0

Motor Efficiencies and Power Factor									
Motor Efficiency %						Power Factor %			
HP	Phase	Service Factor Load	100% Load	75% Load	50% Load	Service Factor Load	100% Load	75% Load	50% Load
1	1	62	60	55	47	74	67	60	51
1	3	64	61.5	55.5	46	75.5	71	62	48.5
1.5	1	61	63	62	56	80	77	71	61
1.5	3	68	67	63.5	56	69.5	66	59.5	50
2	1	61	59	54	45.5	73	68	60	51
2	3	71	69	64	54	71.5	58.5	51	43
3	1	60	60	60	54	78	78	71	60
3	3	73	73	70.5	64	69	69	62	51

# Performance Data

## 1750 RPM

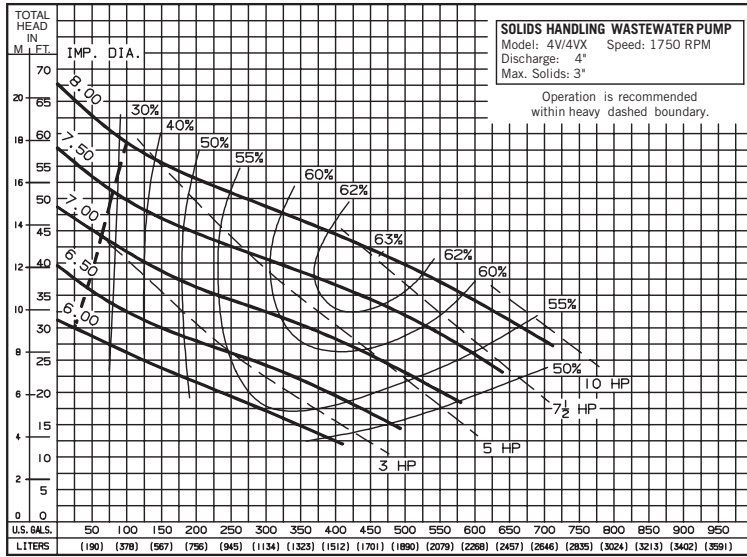

Available Models		Motor Electrical Data											
Standard	Hazardous Location	HP	Volts	Phase	Hertz	Start Amps	Full Load Amps	Service Factor Amps	Full Load kW	Start KVA	Full Load KVA	NEC Code Letter	Service Factor
4V30M4-21	4VX30M4-21	3	230	1	60	106	17.5	21	4.5	24.4	4.8	K	1.2
4V30M4-03	4VX30M4-03	3	208	3	60	86	15	18	5.0	30.9	5.4	M	1.2
4V30M4-23	4VX30M4-23	3	230	3	60	52	12	14.4	4.6	20.1	4.8	H	1.2
4V30M4-43	4VX30M4-43	3	460	3	60	26	6	7.2	4.5	20.1	4.8	H	1.2
4V30M4-53	4VX30M4-53	3	575	3	60	25	5	6	4.6	25.1	5.0	K	1.2
4V50M4-21	4VX50M4-21	5	230	1	60	153	34	41	6.7	35.2	7.8	H	1.2
4V50M4-03	4VX50M4-03	5	208	3	60	140	21.6	26	8.0	50.4	8.6	M	1.2
4V50M4-23	4VX50M4-23	5	230	3	60	125	18	21.6	7.6	49.7	8.4	L	1.2
4V50M4-43	4VX50M4-43	5	460	3	60	62	9	10.8	7.6	49.3	8.4	L	1.2
4V50M4-53	4VX50M4-53	5	575	3	60	45	7.2	8.6	7.6	44.8	8.4	K	1.2
4V75M4-03	4VX75M4-03	7.5	208	3	60	221	32.2	37	10.2	79.5	11.6	M	1.2
4V75M4-23	4VX75M4-23	7.5	230	3	60	164	28	32	9.7	65.3	11.1	K	1.2
4V75M4-43	4VX75M4-43	7.5	460	3	60	82	14	16	9.7	65.3	11.1	K	1.2
4V75M4-53	4VX75M4-53	7.5	575	3	60	75	11.2	13	7.6	74.6	11.1	L	1.2
4V100M4-03		10	208	3	60	221	37	37	12.7	79.5	13.9	J	1.0
4V100M4-23		10	230	3	60	164	32	32	12.0	65.3	13.0	H	1.0
4V100M4-43		10	460	3	60	82	16	16	12.0	65.3	13.0	H	1.0
4V100M4-53		10	575	3	60	75	13	13	11.7	74.6	13.7	J	1.0

Motor Efficiencies and Power Factor									
Motor Efficiency %					Power Factor %				
HP	Phase	Service Factor Load	100% Load	75% Load	50% Load	Service Factor Load	100% Load	75% Load	50% Load
3	1	73	73	70	63	88	85	80	70
3	3	74	73.5	69.5	61.5	73	70.5	62.5	52
5	1	67.5	68	65	56	83	81	73	62.5
5	3	75	76	76	71	86	83	76	65
7.5	3	75	75	72.5	65	77	72	62	49.5
10	3	75	75	75	71	79	79	72	58

# Dimensions

[Dimensions in inches, [ ] Dimensions in mm]

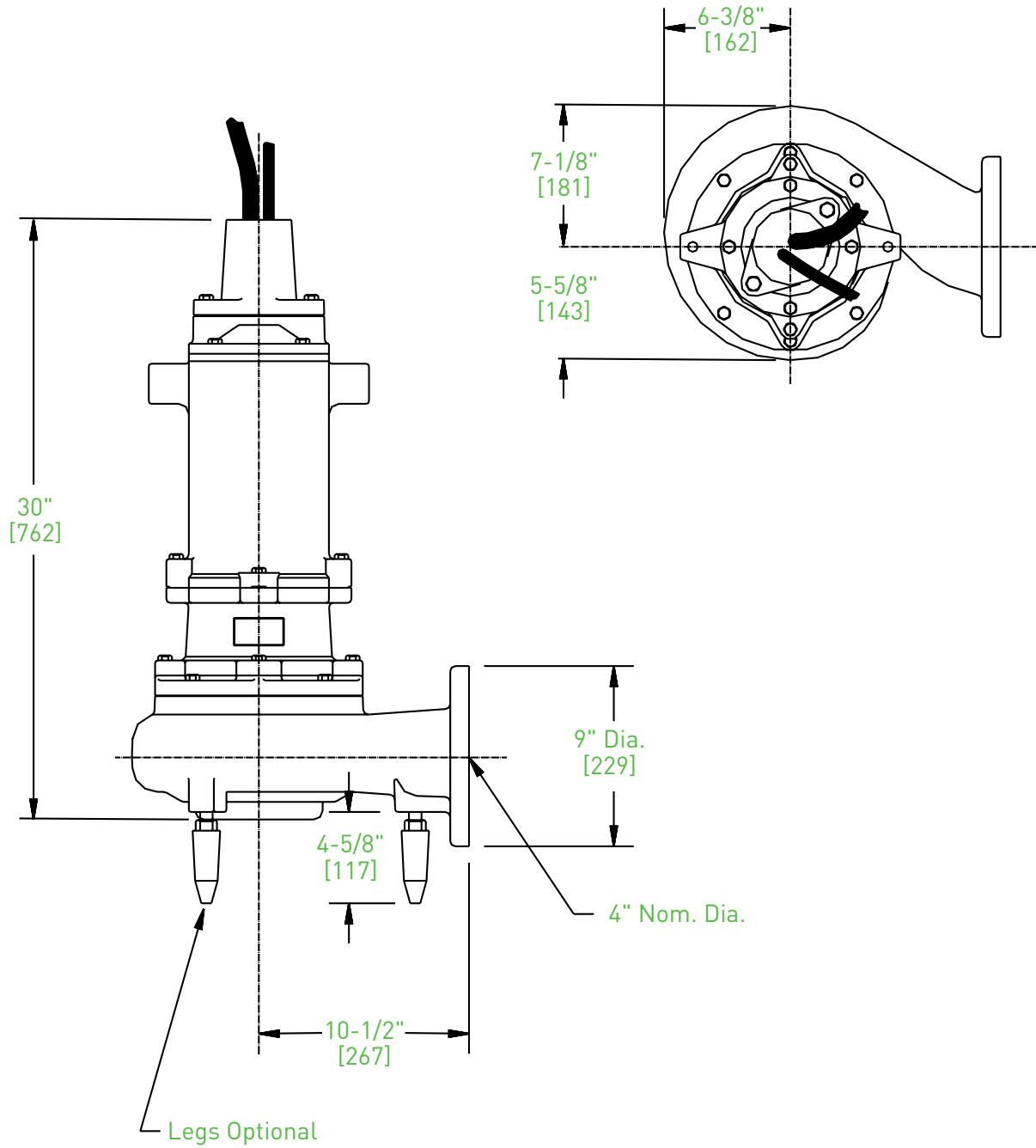

# Contact Myers® For All of Your Engineered Wastewater Systems



SOLIDS HANDLING PUMPS



CUSTOM CONTROLS



GRINDER PUMPS



1101 MYERS PARKWAY  
ASHLAND, OHIO 44805  
PH: 855-274-8947  
WWW.FEMYERS.COM

490 PINEBUSH ROAD, UNIT 4  
CAMBRIDGE, ONTARIO, CANADA N1T 0A5  
PH: 800-363-7867  
WWW.FEMYERS.COM

Because we are continuously improving our products and services, Pentair reserves the right to change specifications without prior notice.  
K3374 05/30/17 © 2017 Pentair plc. All Rights Reserved.