

INSTALLATION INSTRUCTIONS

HYMAX[®]

Repair the past. Connect the future.

KRAUSZ is the creator of HYMAX

HYMAX GRIP[®] (3" - 12")

HYMAX GRIP[®] MJ CUT-IN-SLEEVE



WARNING



CAUTION: THIS PRODUCT IS NOT INTENDED FOR USE ON NATURAL GAS PIPING, OR ANY OTHER TYPE OF GAS PIPING. THIS COULD RESULT IN ESCAPING GAS THAT COULD IGNITE AND CAUSE PROPERTY DAMAGE, SERIOUS INJURY OR DEATH.



IMPORTANT

THE HYMAX GRIP MJ Cut-In Sleeve is a stab-on type restraint coupling with an MJ connection on one side, that is approved for use with metal and plastic pipes when installing a new element on existing line.

THE HYMAX GRIP SERIES ARE STAB-ON TYPE COUPLINGS. Do not disassemble the product. Do not loosen the bolts

LUBRICATION OF PRODUCT AND PIPES except steel, PVC, and PE pipes, all rough-surfaced pipes must be lubricated with a water-based gasket lubricant in order to achieve a proper seal.

DO NOT LUBRICATE BOLTS AND NUTS. Bolts are pre-lubricated with a MAG (Molecular anti-galling) coating. Greasing bolts or nuts voids manufacturer's warranty.

TIGHTEN BOLTS TO THE TORQUE value provided on the label in one continuous step. Krausz products do not require a gradual increase of torque over a specified period, nor do they require re-torque. The minimal torque requirements must be achieved prior to any recharging of the line.

USE A TORQUE WRENCH TO TIGHTEN THE BOLTS. A torque wrench will assure a proper torque has been applied to the coupling. Do not use other tools to tighten the coupling's bolts!

PIPE STIFFENERS OR INSERTS ARE REQUIRED when used on HDPE pipes.

DO NOT USE HYMAX GRIP ON AC OR FRP PIPES!

PREPARE PRODUCT AND PIPE FOR INSTALLATION:

1

CLEAN AND DESCALE THE PIPE

Make sure that:

- The pipe is clear from debris
- The pipe is not out of round and is free of scratches, dents, flats and defects
- The end rings are centered on the coupling - if they are not, please contact your local distributor for return and replacement

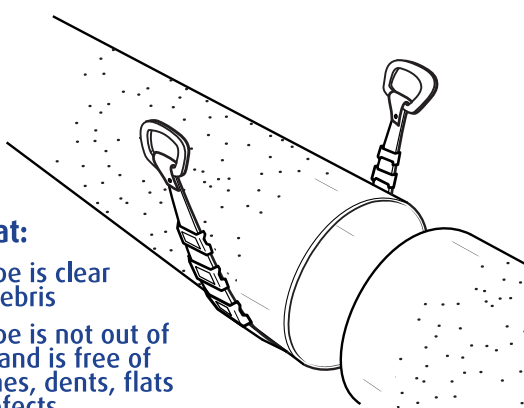

2

CUT THE PIPE ACCORDING TO:

- The width of the new element
 - The G-min/G-max of the HYMAX GRIP Cut-in Sleeve product/s
- Both variants are indicated on the product label.

3

MEASURE THE PIPE TWICE

RANGE

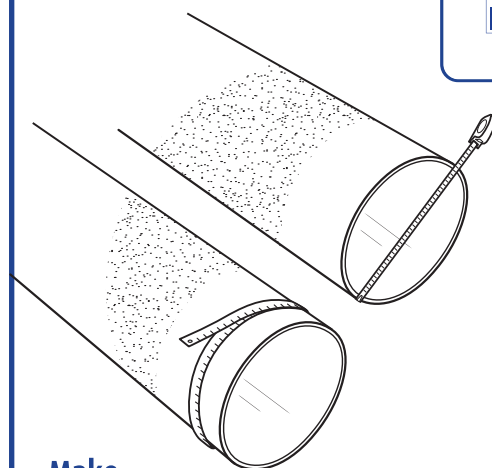
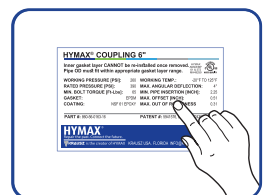

Make sure that:

the coupling size range (as indicated on the product's label) will fit the pipes properly

HYMAX[®]

Repair the past. Connect the future.

 **KRAUSZ** is the creator of HYMAX