

# CENTRIFUGAL PUMPS

## SELF-PRIMING TURF BOSS 3-5 HP



### FEATURES

- Volute: Built-in suction check valve facilitates priming and prevents back flow or siphoning
- Impeller: Cast iron; combines efficient operation with durable construction to allow for use in a broad range of pumping applications
- Seal: Standard carbon/ceramic faces; FKM elastomers; 300 series stainless steel components
- Diffuser: Cast iron is utilized in all models to improve pump efficiency
- Motor: Standard JM frame

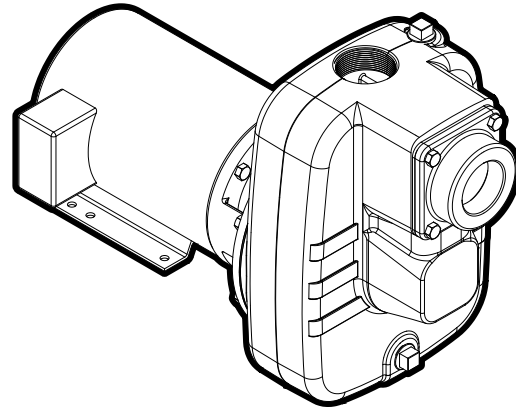

### SPECIFICATIONS

- Capacities to 160 gpm
- Heads to 170 feet
- 75 psi maximum working pressure
- 120 °F maximum temperature
- Clockwise rotation when viewed from motor end
- NPT pipe connections

HP	Discharge	Suction
3	2"	2"
5	2"	2-1/2"

### APPLICATIONS

- Irrigation
- Construction
- Commercial
- Municipal
- Light Industrial
- Residential
- Water Transfer

# CENTRIFUGAL PUMPS

SELF-PRIMING TURF BOSS 3-5 HP



## PERFORMANCE

NOMINAL SPEED: 3600 RPM

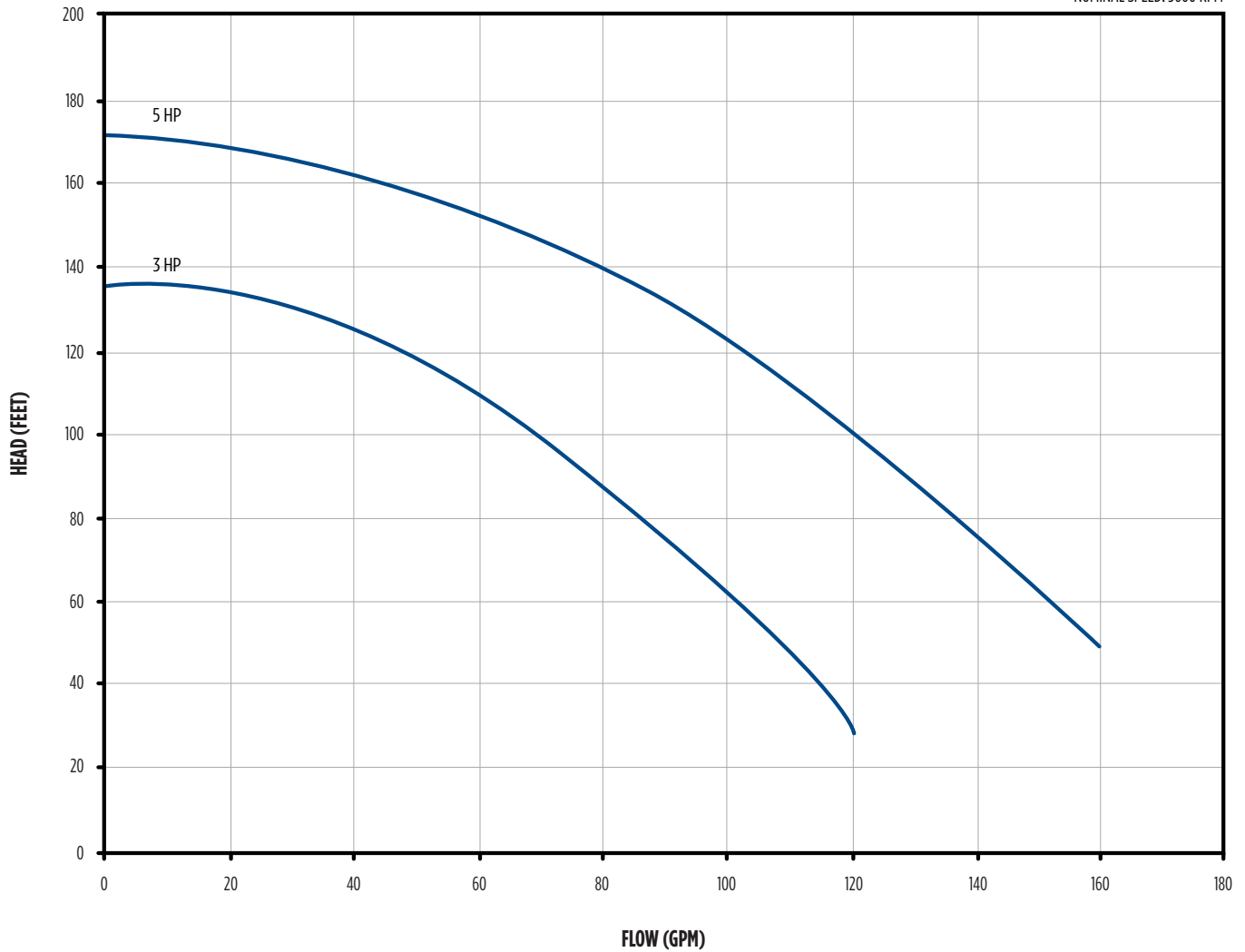

# CENTRIFUGAL PUMPS

## SELF-PRIMING TURF BOSS 3-5 HP



### ORDER INFORMATION

Model	ECNL	HP	Pump Size (Suc. x Dis.)	Phase	Volts	SFA	Pump Unit	
							Order No.	Wt. (lbs)
FTB3CI	ODP	3	2" x 2"	1	115/230	33.4/16.7	92980030	120
FTB3CI-E	TEFC	3	2" x 2"	1	115/230	33.4/16.7	92980130	123
FTB3CI-T	ODP	3	2" x 2"	3	230/460	8.4/4.2	92980035	93
FTB3CI-TE	TEFC	3	2" x 2"	3	230/460	8.2/4.1	92980135	94
FTB3CI-TSE	TEFC	3	2" x 2"	3	575	3.3	92980136	94
FTB5CI	ODP	5	2-1/2" x 2"	1	230	25.3	92980050	135
FTB5CI-E	TEFC	5	2-1/2" x 2"	1	230	19	92980150	140
FTB5CI-T	ODP	5	2-1/2" x 2"	3	230/460	13.8/6.9	92980055	111
FTB5CI-TE	TEFC	5	2-1/2" x 2"	3	230/460	13.4/6.7	92980155	128
FTB5CI-TSE	TEFC	5	2-1/2" x 2"	3	575	5.4	92980156	121

### PUMP END KITS

Model	HP	Pump Size (Suc. x Dis.)	Pump Unit	
			Order No.	Wt. (lbs)
FTB3CI-PE	3	2" x 2"	92980033	60
FTB5CI-PE	5	2-1/2" x 2"	92980053	

### DIMENSIONS

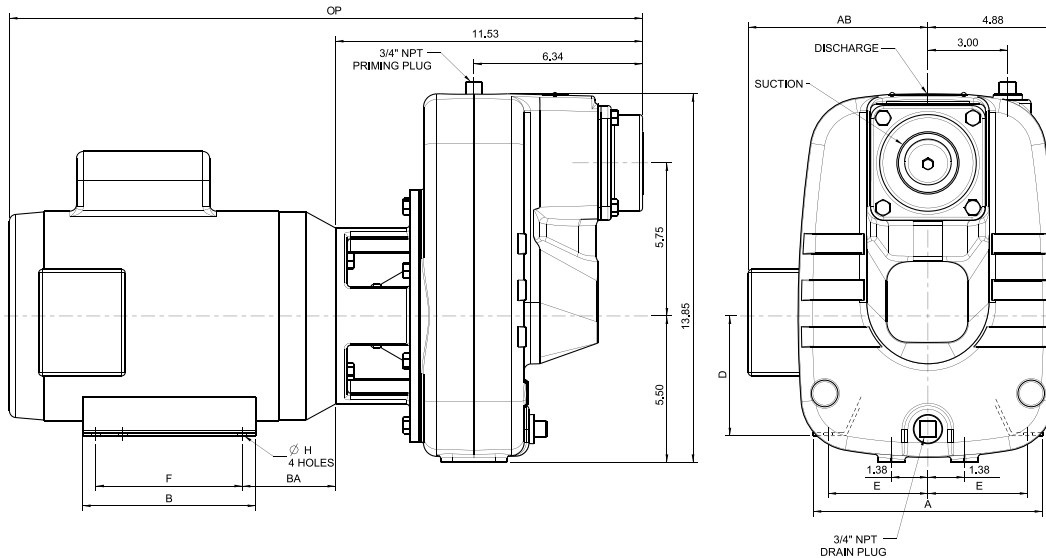

Model	Enclosure	Pump Size (SUC. X DIS)	Dimensions (in.)								
			A	B	D	E	F	H	AB	BA	OP
FTB3CI	ODP	2" X 2"	8.63	6.50	4.50	3.75	5.50	0.41	6.75	3.50	23.78
FTB3CI-E	TEFC	2" X 2"	8.63	6.50	4.50	3.75	5.50	0.44	6.87	3.50	29.59
FTB3CI-T	ODP	2" X 2"	6.50	5.94	3.50	2.75	5.00	0.34	5.62	2.88	22.41
FTB3CI-TE	TEFC	2" X 2"	6.50	5.94	3.50	2.75	5.00	0.38	5.74	2.88	23.57
FTB3CI-TSE	TEFC	2" X 2"	6.50	5.94	3.50	2.75	5.00	0.38	5.74	2.88	23.57
FTB5CI	ODP	2 1/2" X 2"	8.63	6.50	4.50	3.75	5.50	0.41	6.75	3.51	23.78
FTB5CI-E	TEFC	2 1/2" X 2"	8.63	6.50	4.50	3.75	5.50	0.45	6.87	3.50	26.83
FTB5CI-T	ODP	2 1/2" X 2"	8.63	6.50	4.50	3.75	5.50	0.41	6.74	3.50	23.78
FTB5CI-TE	TEFC	2 1/2" X 2"	8.63	6.50	4.50	3.75	5.50	0.41	6.87	3.50	25.34
FTB5CI-TSE	TEFC	2 1/2" X 2"	8.63	6.50	4.50	3.75	5.50	0.41	6.87	3.50	25.34

NOTE: Dimensions are for estimating purposes only

# CENTRIFUGAL PUMPS

SELF-PRIMING TURF BOSS 3-5 HP



## REPAIR PARTS

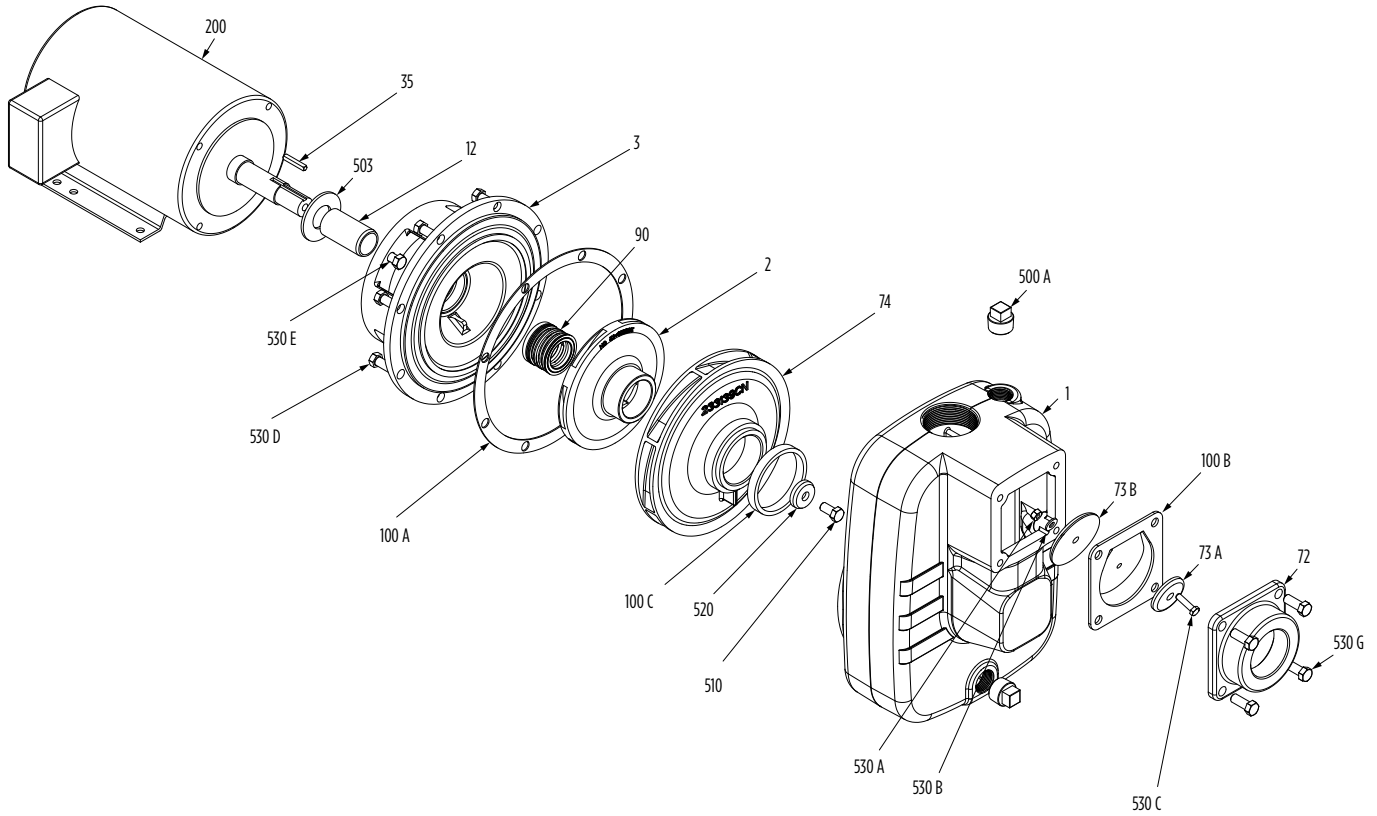

# CENTRIFUGAL PUMPS

## SELF-PRIMING TURF BOSS 3-5 HP



### REPAIR PARTS

Fig. No.	Part Description	Part No.		Materials of Construction
		3 HP	5 HP	
1	Pump Case	305461011		Cast iron, ASTM-A48 CL30
2	Impeller	305453025	305453026	Cast iron, ASTM-A48 CL30
3	Motor Adapter	305461012		Cast iron, ASTM-A48 CL30
12	Mechanical Seal Shaft Sleeve	305458011		416 Stainless steel
35	Shaft Key	305453028	305451003	301 Stainless steel
72	Check Valve	305455010	305460018	Cast iron, ASTM-A48 CL30
73A	Top Weight, Check Valve	305455011		Cast iron, ASTM-A48 CL30
73B	Bottom Weight, Check Valve	305455012		Cast iron, ASTM-A48 CL30
74	Diffuser	305460019		Cast iron, ASTM-A48 CL30
90	Mechanical Shaft Seal	305457011		Carbon/ceramic x FKM/stainless steel
100A	Case Gasket	305461013		Nitrile
100B	Flapper Valve	305454043		Neoprene
100C	Square-Ring, Volute	305463131		Nitrile
200	Motor	See Motor section		Misc.
500	Pipe Plug, 3/4" (2 req.)	305463050		CAD-plated steel
503	Water Slinger	305453030		Neoprene
510	Bolt, Impeller	305461014		416 Stainless steel
520	Washer, Impeller	305448013	305455014	417 Stainless steel
530A	Nut, Flapper	305463082		300 Stainless steel
530B	Washer, Flapper	305463084		300 Stainless steel
530C	Bolt, Flapper	305463080		316 Stainless steel
530D	Hex Bolts, Volute (8 pack)	305463064		Zinc-plated steel
530E	Hex Bolt, Motor Adapter (4 req.)	305463120	305463121	Zinc-plated steel
530G	Hex Bolt, Check Valve	305463010		Zinc-plated steel

# NOTES

SELF-PRIMING TURF BOSS 3-5 HP



# NOTES

SELF-PRIMING TURF BOSS 3-5 HP



