

LAWN SPRINKLER, IRRIGATION PUMP

MODEL #, SP10P1, SP15P1, SP20P1,
EL10P1, EL15P1, EL20P1

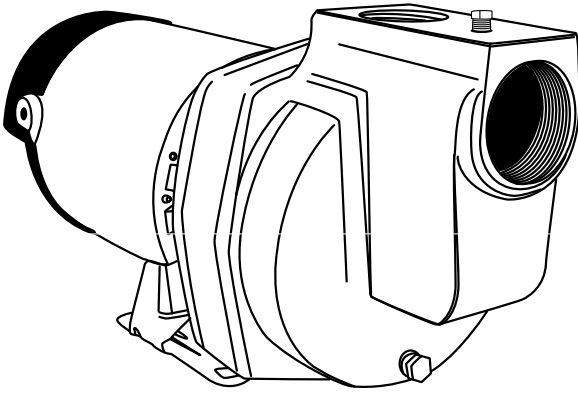

! SAFETY INFORMATION

Please read and understand this entire manual before attempting to assemble, operate or install the product. If you have any questions regarding the product, please call customer service at 1-800-742-5044, 7:30 a.m.-5:00 p.m., EST, Monday-Friday.

DANGER

ELECTRICAL SHOCK HAZARD.

Always disconnect power source before performing any work on or near the motor or its connected load. If the power disconnect point is out-of-sight, lock it in the open position and tag it to prevent unexpected application of power. Failure to do so could result in fatal electrical shock.

ELECTRICAL SHOCK HAZARD.

Do not handle the pump with wet hands or when standing in water as fatal electrical shock could occur. Disconnect main power before handling unit for ANY REASON!

RISK OF ELECTRIC SHOCK.

These pumps have not been investigated for use in swimming pool areas.

WARNING

ELECTRICAL SHOCK ALERT.

Follow all local electrical and safety codes, as well as the National Electrical Code (NEC) and the Occupational Safety and Health Act (OSHA).

ELECTRICAL SHOCK ALERT.

Replace damaged or worn wiring cord immediately.

ELECTRICAL SHOCK ALERT.

Do not kink power cable and never allow the cable to come in contact with oil, grease, hot surfaces, or chemicals.

ELECTRICAL SHOCK ALERT.

Unit must be securely and adequately electrically grounded. This can be accomplished by wiring the unit to a ground metal-clad raceway system or by using a separate ground wire connected to the bare metal of the motor frame or other suitable means.

CHEMICAL ALERT.

This product contains chemicals known to the State of California to cause cancer and birth defects or other reproductive harm.

CAUTION

ELECTRICAL SHOCK MAY OCCUR

Protect the power cable from coming in contact with sharp objects.

HOT SURFACE MAY CAUSE BURNS

Be careful when touching the exterior of an operating motor - It may be hot enough to be painful or cause injury.

PRODUCT DAMAGE MAY RESULT

Make certain that the power source conforms to the requirements of your equipment.

PREPARATION

Before beginning installation of product, make sure all parts are present. Compare parts with package contents drawing. If any part is missing or damaged, do not attempt to assemble

Tools Required for Assembly:

Hacksaw
Pipe Wrenches (2)
Wire Strippers
Needle-Nose Pliers
Phillips Screwdriver
Wire Cutters
Adjustable Wrench

Parts Required For Assembly:

2" foot valve or 2" suction strainer with check valve
2 in. Sched 40 PVC pipe
1-1/2 in. Sched 40 PVC pipe
2 in. MPT x 2 in. slip adaptor
1-1/2 in. MPT x 1-1/2 in. slip adaptor
1-1/2 in. pipe tee
1-1/2 in. slip x 1-1/4 in. FPT reducer bushing,
1-1/4 in. MPT plug
2 in. 90° pipe elbow
1-1/2 in. 90° pipe elbow
thread tape
1/4 in. electric wire strain relief

the product. Contact customer service for replacement parts.

Estimated Installation Time: 2 hours.

2-step PVC glue system (primer and sealer)
Thread paste.

Optional Parts For Assembly (not included):

- Priming Plug with Pressure Gauge:** Used instead of a priming plug alone. Helps determine if the pump is primed, indicates if the pump is operating properly and what kind of pressure is in the system when operating.
 - (1) 1-1/4 in. MPT x 1/2 in. FPT reducer bushing
 - (1) 1/2 in. MPT x 1/4 in. FPT reducer bushing
 - (1) 100 PSI pressure gauge
- Unions:** Used for easy removal of the pump from the sprinkler system.
 - (2) 2 in. union
 - (1) 1-1/2 in. union
- (1) 1-1/2 in. Ball Valve:** Prevents back flow of water from the sprinkler system when the pump is removed from the system.
- 1-1/2 in. Couplers:** Quantity determined by the total length of pipe used.
- 2 in. Couplers:** Quantity determined by the total length of pipe used.

Component	Specifications
Pump housing	Heavy-duty, cast-iron
Diffuser	Thermoplastic
Impeller	Thermoplastic
Rotary seal	Carbon/silicon carbide
Mounting ring	Heavy-duty, cast-iron
Square cut ring	Buna-N
Base	Rigid steel
Motor	Dual voltage, double-ball bearing

MOTOR DATA CHART					
HP	Phase	Volts	Code Letter	Max Amps	Locked Rotor Amps
1	1	115	H	17.6	62.0
	1	230		8.8	31.0
1-1/2	1	115	G	18.00	72.0
	1	230		9.00	36.0
2	1	115	G	21.00	108.0
	1	230		10.50	54.0

GENERAL PUMP INFORMATION

Typical Pump Setup

Typical setups for lawn sprinkler pump systems include ground water wells (Fig. 1) or surface water, such as lakes, ponds or streams. (Fig. 3)

Location

For best performance, the pump must be located as close to the water source as possible and protected from the elements.

Ventilation

Ventilation and drainage must be provided to prevent damage to the motor from heat and moisture.

Freezing

The pump and all piping must be protected from freezing. If freezing weather is forecast, drain pump or remove completely from the sprinkler system.

Water Supply

The water source must be able to supply enough water to satisfy the capacity of the pump and water needs. See performance chart.

⚠ WARNING: NEVER run pump against a closed discharge. Doing so can boil water inside pump, causing hazardous pressure in unit, risk of explosion and possibly scalding persons handling pump. (Fig. 2)

Vertical Lift

Vertical lift is the vertical distance from the lowest level of the water to the pump intake. The pump will move water as long as the pump is within 25 vertical feet of the water source.

Horizontal Distance

The horizontal distance is the horizontal measurement between the pump inlet and the water source. This distance may affect the ability of the pump to operate. If it is over 60 feet, call customer service at 1-866-994-4148.

Pipe And Fittings

Use galvanized steel or NSF PW Schedule 40 PVC pipe and fittings. This material is designed for water pressure and will seal against air and water under pressure. Do Not Use: DWV fittings, as these are designed for drains without pressure and will not seal properly.

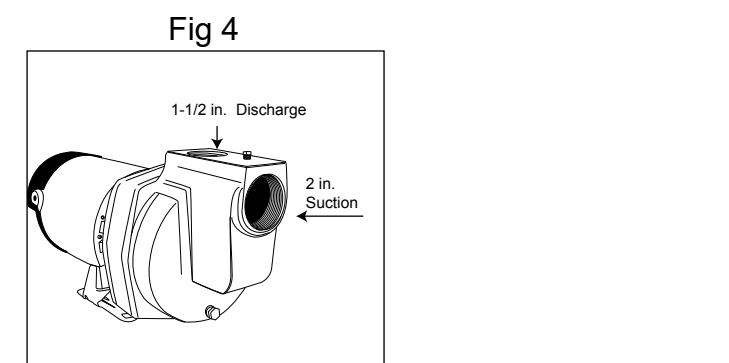
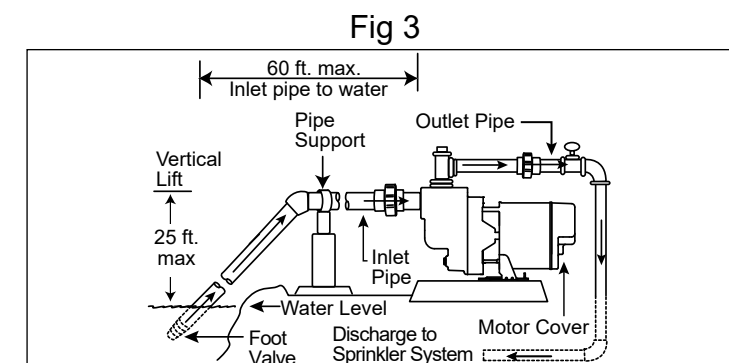
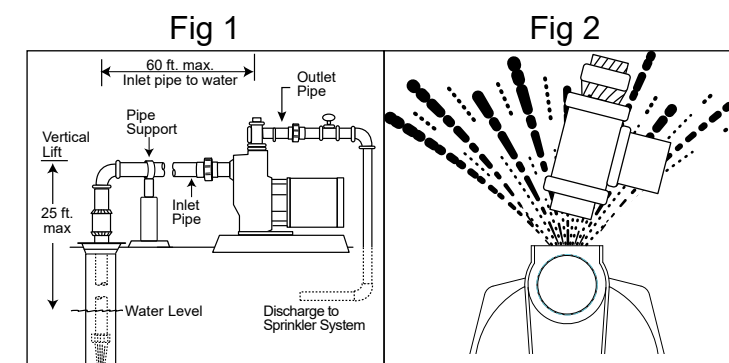

⚠ CAUTION: The entire system must be air and water tight for efficient operation and to maintain prime.

Wire Size:

The wire size is determined by the distance from the breaker box to the pump motor, and the horsepower rating of the motor. See the wire chart for proper wire size.

⚠ CAUTION: Dry-fit entire assembly to ensure proper fit before gluing or taping parts.

⚠ CAUTION: Follow all proper gluing procedures as specified by the glue manufacturer. Always glue in a vertical direction whenever possible to prevent glue from dripping inside pipe or fittings

⚠ CAUTION: Use thread tape and a thread paste compound on all male threads except for the unions. Tighten securely with a wrench and add another 1/4 turn to ensure proper seal.

1. Thread 1-1/2 in. MPT x 1-1/2 in. slip adaptor into the outlet port located at the top of the pump.
2. Glue a 6 in. piece of 1-1/2 in. pipe into the adaptor.
3. Glue a 1-1/2 in. tee to the pipe.
4. Glue a 1-1/2 in. slip x 1-1/4 in. adaptor to the top opening of the 1-1/2 in. tee.
5. Thread in a 1-1/4 in. priming plug or optional priming plug with pressure gauge.

NOTE: Hand tighten only, as this will be removed for priming.

6. Glue another 6 in. section of 1-1/2 in. pipe into the opening in the 1-1/2 in. tee.
7. Glue the male thread side of a 1-1/2 in. union to the pipe.
8. Thread 2 in. MPT x 2 in. slip adaptor into the inlet port located on the front of the pump body.
9. Glue an 8 in. section of 2 in. pipe into the 2 in. adaptor.
10. Glue one side of a 2 in. union to the pipe.

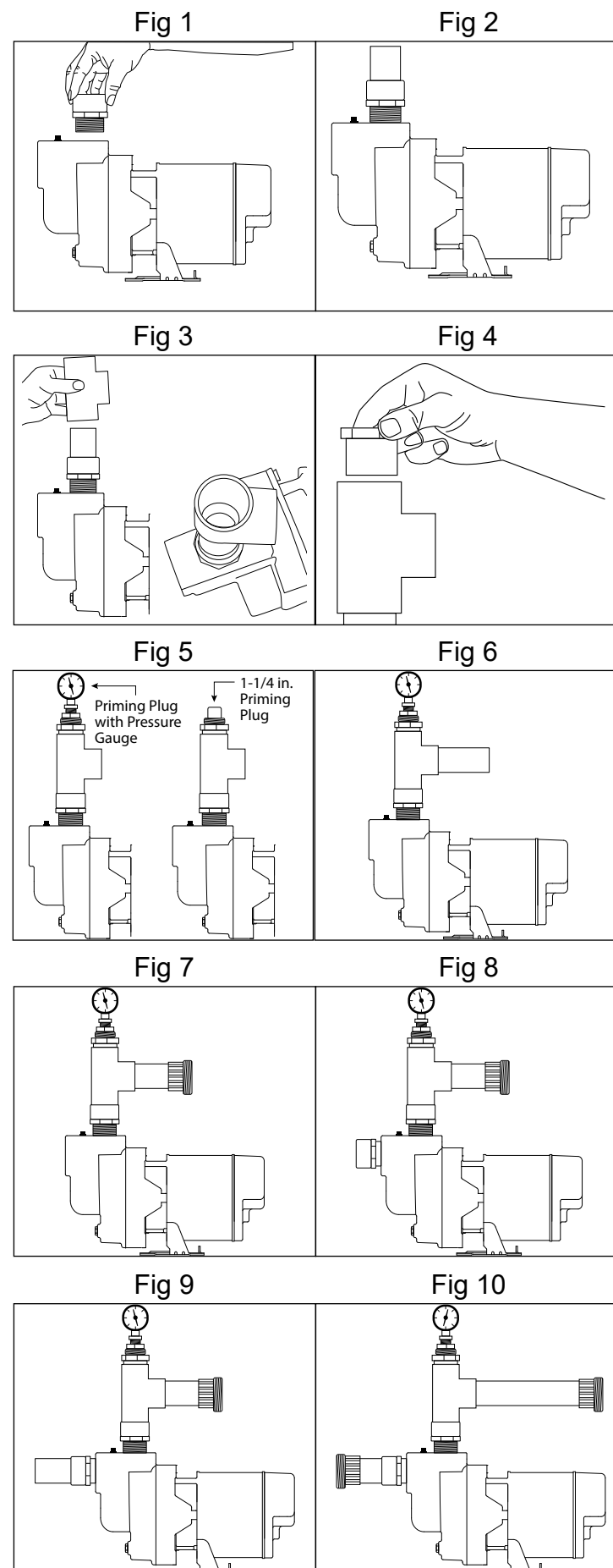

For Well Installations

11. Thread a 2 in. MPT x 2 in. slip adaptor into the foot valve.
12. Glue 2 in. pipe into the adaptor. Glue enough sections of pipe together using 2 in. couplers in order for the foot valve to be completely submerged in water. Be sure inlet pipe will remain fully submerged at the lowest expected level of the water source.
13. Install well seal in order to hold the inlet pipe in position in the well.
14. Glue a 90° elbow when the inlet pipe is in line with the inlet port of the pump.

For Surface Water Installations

- For surface water installations, follow steps 11 and 12 above and then:
15. Glue a 45° elbow when the inlet pipe is in line with the inlet port of the pump.
 16. Support inlet pipe with pipe support.

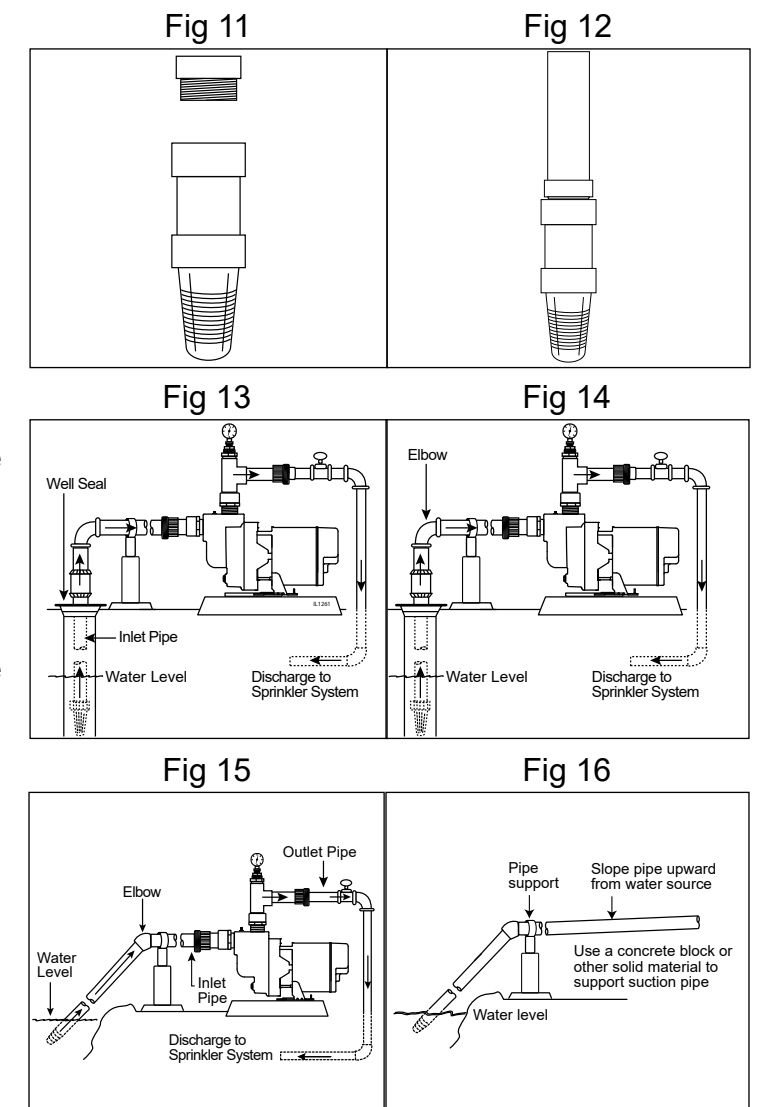

1. Mount pump on a solid foundation as close to the water source as possible.

CAUTION: Support the 2 in. inlet pipe from the well or lake to the inlet port to prevent sagging. Sagging will create air pockets within the pipe that will prevent the pump from priming and operating correctly.

2. Glue female 2 in. union to the end of inlet pipe leading from the water source.
3. Connect the 2 in. union together to complete the inlet line to the pump.
4. Glue a 6 in. piece of 1-1/2 in. pipe to the female portion of the 1-1/2 in. union.
5. Glue 1-1/2 in. ball valve to the other end of the 6 in. piece of pipe.
6. Connect the 1-1/2 in. outlet pipe to the sprinkler system by gluing in additional sections of pipe as needed.
7. Connect union to ensure proper fit. Do not tighten until after priming.

CAUTION: Do not glue union together.

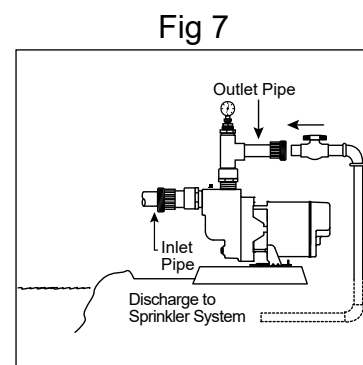
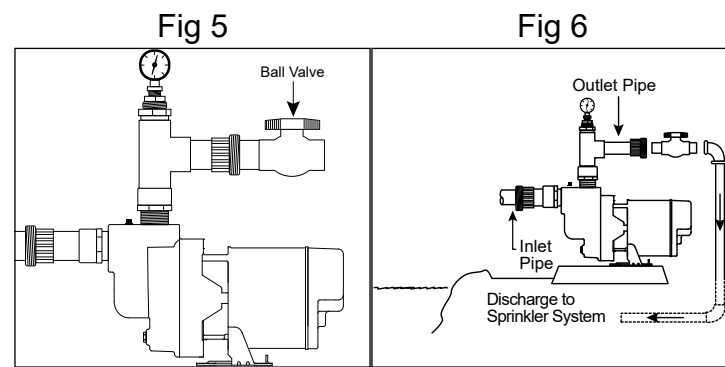
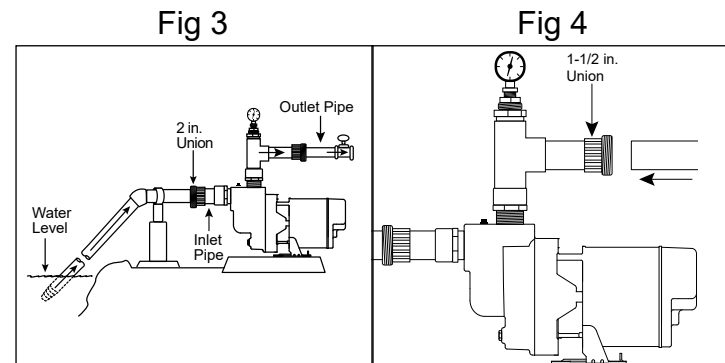
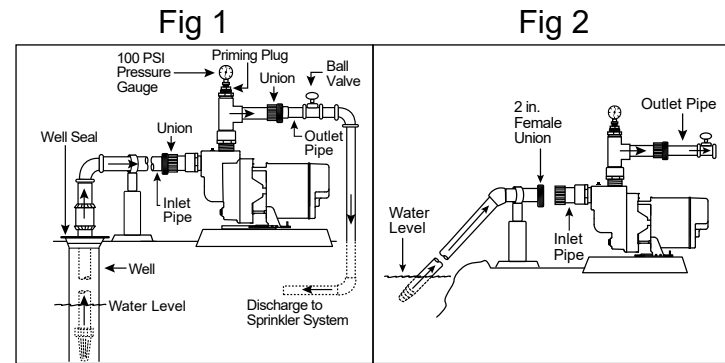

WARNING

ELECTRICAL SHOCK ALERT.

Under-size wiring can cause motor failure and even fire. Use proper wire size specified in the wire size chart.

ELECTRICAL SHOCK ALERT.

Replace damaged or worn wiring cord immediately.

ELECTRICAL SHOCK ALERT.

Do not kink power cable and never allow the cable to come in contact with oil, grease, hot surfaces, or chemicals.

ELECTRICAL SHOCK ALERT.

The pump must be properly grounded using the proper wire cable with ground.

ELECTRICAL SHOCK ALERT.

Always disconnect pump from electricity before performing any work on the motor.

WARNING

ELECTRICAL SHOCK MAY OCCUR

All wiring should be performed by a qualified electrician in accordance with the National Electric Code and local electric codes.

ELECTRICAL SHOCK MAY OCCUR

Connect the pump to a separate electrical circuit with a dedicated circuit breaker. Reference the wire size chart below for proper fuse size.

ELECTRICAL SHOCK MAY OCCUR

Protect the power cable from coming in contact with sharp objects.

PRODUCT DAMAGE MAY RESULT

Make certain that the power source matches the pump requirements. This pump has a dual voltage motor and can run on 115 V or 230 V. This pump is wired from the factory to run on 230 volts; refer to Electrical Instructions if you want to change the pump to run on 115 volts.

WIRE SIZE CHART

Distance From Motor To Fuse Box, Meter or Electrical Outlet	Minimum Copper Wire Size Chart (Gauge)					
	Single Phase Motors					
	1 HP		1-1/2 HP		2 HP	
	115 Volt	230 Volt	115 Volt	230 Volt	115 Volt	230 Volt
0-50 Ft.	12	14	12	14	12	14
50-100 Ft.	10	14	10	14	10	14
100-150 Ft.	8	12	8	12	8	12
150-200 Ft.	*	12	*	12	*	10
200-300 Ft.	*	10	*	10	*	10
Fuse Size (Amps)	30	15	30	20	30	20

(*) Not economical to run in 115V, use 230V

PUMP ELECTRICAL CONNECTIONS

1. Remove rear motor cover on pump by unscrewing the two screws.
2. Thread electric wire strain relief into wire opening on the side of the motor of pump.
3. Insert wire through electric wire strain relief and tighten screws.
4. Connect white power lead to L1 and black power lead to L2.
5. Connect green ground wire to green grounding screw. Re-install rear motor cover to pump.

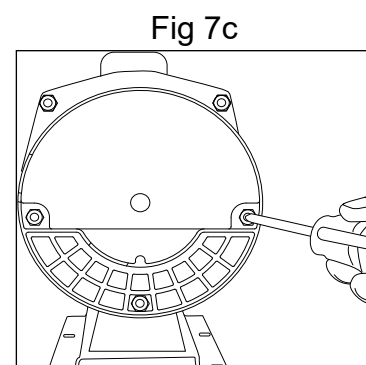
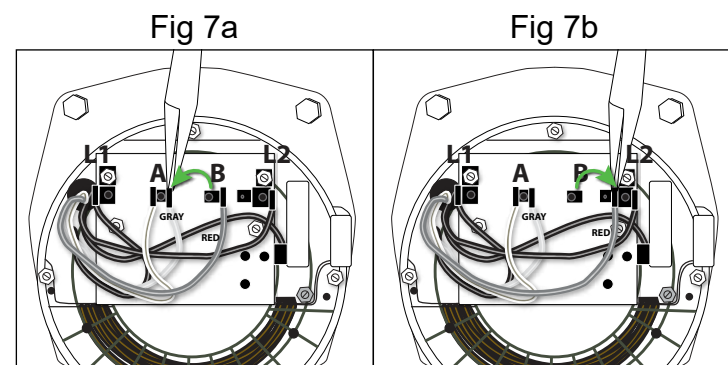
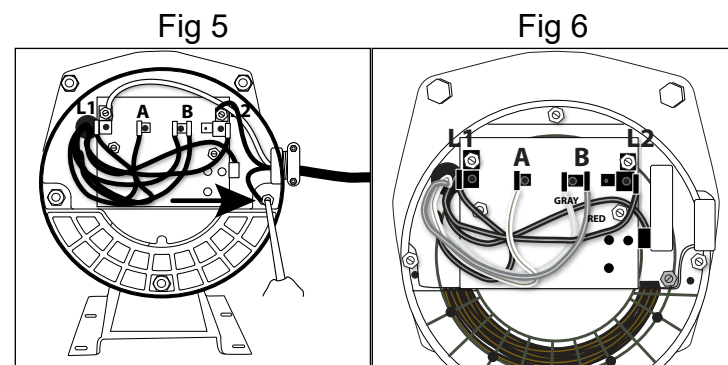
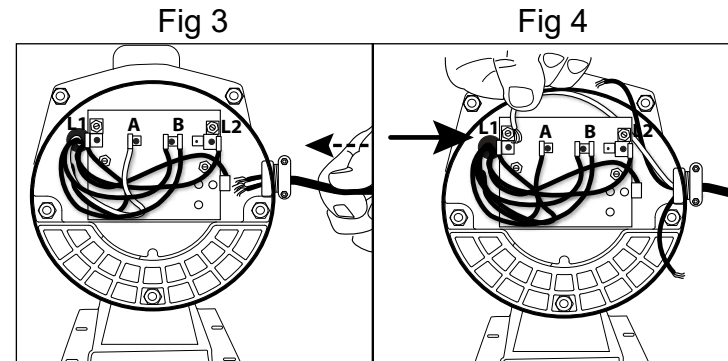
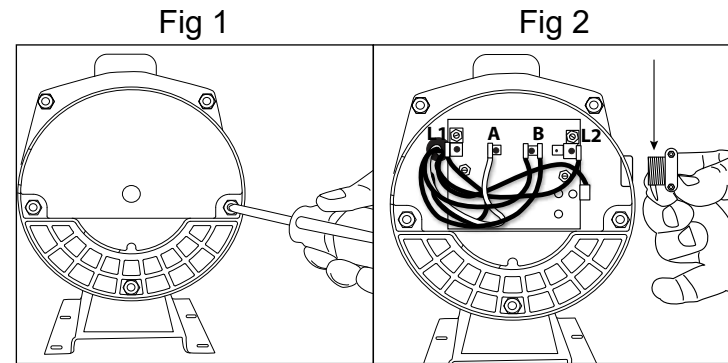

To change from 230 V to 115 V

6. The motor of pump is dual voltage and can run on either 115 volts or 230 volts. In general, 230 volts is more economical to run, and requires a smaller wire size. The pump is pre-set in the factory to run at 230 volts.
7. For 115 volts service, change the following wires on the terminal board:
 - a. Using a pair of needle nose pliers, pull the gray wire with the female flag connector from the "B" terminal spade post. Place it to the left on the "A" terminal space post.
 - b. Pull the red wire with the female flag connector from the "B" terminal. Place it to the right on the L2 terminal space post.
 - c. Reinstall the rear motor cover.

PUMP PRIMING & STARTUP

⚠ CAUTION: All pumps must be primed by filling the pump cavity with water before they are first operated. This may take several gallons of water, as the entire inlet line will be filled in addition to the pump cavity. The longer the inlet line, the more water is required for priming.

1. Disconnect the 1-1/2 in. outlet union and separate the pipe.
2. Remove the air relief plug on top of pump and the 1-1/4 in. priming plug with pressure gauge or plug. Refer to Pump Preparation Step 5.
3. Slowly fill pump cavity until water comes out of air relief hole on top of the pump.
4. Replace air relief plug and continue adding water to pump cavity until water comes out of the open outlet pipe at the open union.
5. Wait 10 minutes to see if water level drops below the pipe tee. If level drops, check foot valve. If level stays constant, replace the priming plug.
6. Reconnect 1-1/2 in. union on outlet pipe. Open the ball valve (turn handle to line up with pipe), and then turn on breaker to start pump.

⚠ IMPORTANT: If the pump fails to prime within five minutes:

7. Turn the power off at the break box. Check all pipe connections for leaks, making sure all connections are water and air tight. Check the inlet pipe for any sagging, making sure the inlet pipe is in a straight line to the pump. Watch for leaks or a milky color in the discharged water, which indicated an air leak. Re-prime if necessary, following steps 1 through 6 above. Reset breaker at the breaker box.

⚠ IMPORTANT: If the pump hums instead of pumping or turns off repeatedly, shut pump off immediately. Check voltage. Pump is wired to run on 230 volts. If the pump cuts out or stops, you may be attempting to connect to 115 volts. See PUMP ELECTRICAL INSTRUCTIONS to see how to correctly change the motor voltage to 115 volts.

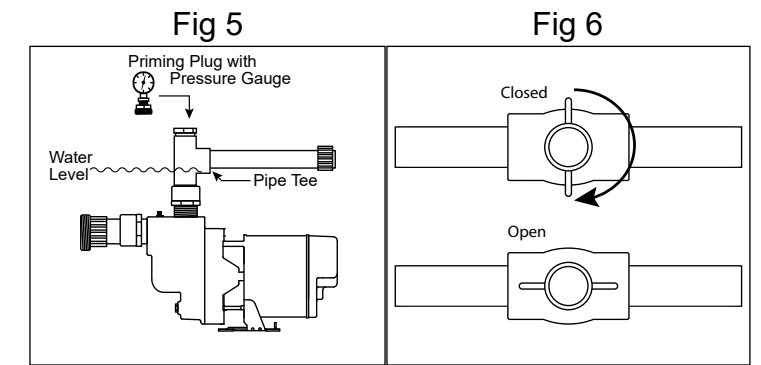
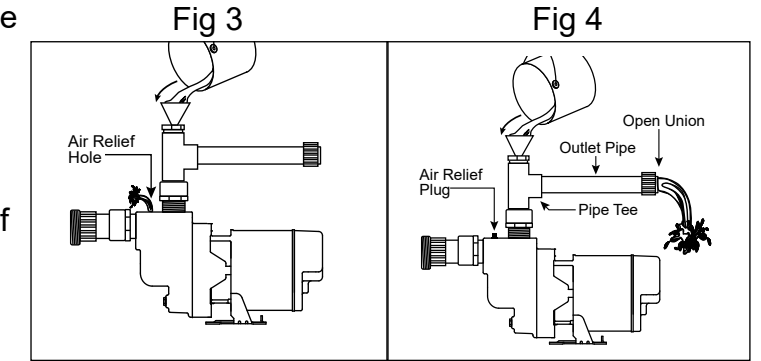
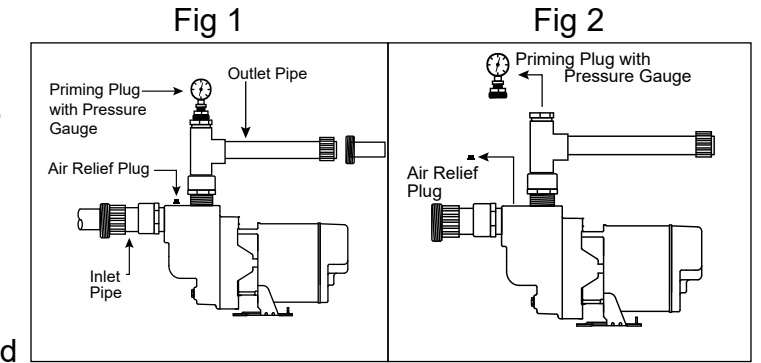

LUBRICATION

The pump and motor requires no lubrication. The ball bearings of the motor have been greased at the factory. Under normal operating conditions they should require no further greasing.

ROTARY SEAL ASSEMBLY REPLACEMENT

CAUTION: Make certain that the power supply is disconnected before attempting to service the unit. The rotary seal assembly must be handled carefully to avoid damaging the precision lapped faces of the sealing components.

See Parts List For Reference Letters

1. Disengage pump body **G** from motor assembly by removing bolts **H**.
2. Remove diffuser **D**.
3. Unthread impeller **C** from motor shaft and remove spring.

NOTE: To remove impeller, place screwdriver within slot in shaft end and hold shaft firmly. Rotate impeller counterclockwise to remove from shaft.

4. Use a screwdriver to remove the rotary seal **B**. Pry the ceramic seal and rubber gasket from the recess of the mounting bracket. (Fig 1).

CAUTION: Be careful not to damage the motor shaft or recess surface.

5. Clean the recess and motor shaft thoroughly.
6. Install the new rotary seal assembly (Fig 2):

NOTE: To make installation easier, apply a drop of liquid soap to the outside diameter of the rubber gasket. Make certain that the ceramic seal is kept clean and free of dirt and/or oil.

- a. Insert the ceramic seal and the rubber gasket into the recess. (Fig 3).
 - b. Slip the remaining parts of the rotary seal assembly onto the motor shaft.
7. Replace the spring, impeller, and diffuser removed in steps 2 and 3.
 8. Reassemble the pump body to the motor and mounting bracket.

Fig 1

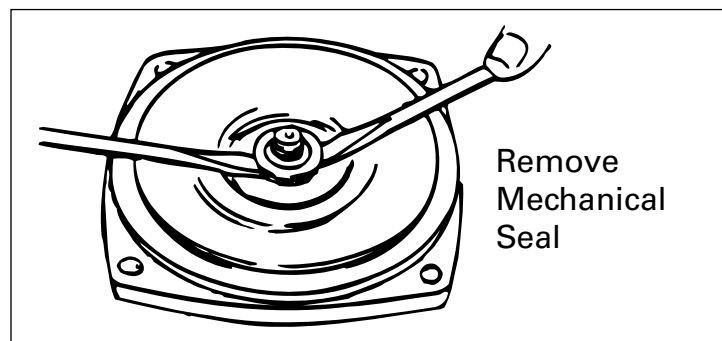

Fig 2 - Rotary Seal Assembly

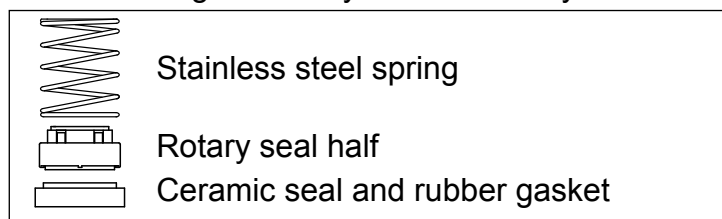
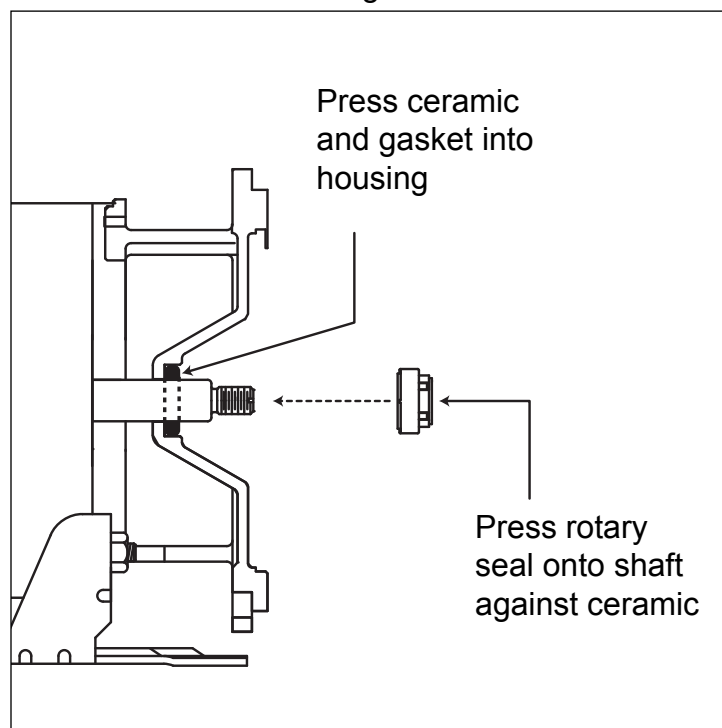

Fig 3



Problem	Possible Cause	Corrective Action
A. Little or no discharge	<ol style="list-style-type: none"> 1. Casing not initially filled with water 2. Vertical lift too high, or too long 3. Hole or air leak in inlet line 4. Foot valve too small 5. Foot valve or inlet line not submerged deep enough in water 6. Motor wired incorrectly 7. Inlet or outlet line valves closed 	<ol style="list-style-type: none"> 1. Fill pump casing 2. Move pump closer to water source 3. Repair or replace inlet line. Use thread tape and pipe sealing compound 4. Match foot valve to piping or install one size larger foot valve. 5. Submerge foot valve lower in water 6. Check wiring diagram 7. Open valves
B. Pump will not deliver water or develop pressure	<ol style="list-style-type: none"> 1. No priming water in casing 2. Leak in inlet line 3. Outlet line is closed and priming air has nowhere to go 4. Inlet line (or valve) is closed 5. Foot valve is leaking 6. Inlet screen clogged 	<ol style="list-style-type: none"> 1. Fill pump casing 2. Repair or replace 3. Open ball valve 4. Open line or valve 5. Replace foot valve 6. Clean or replace inlet screen
C. Loss of suction	<ol style="list-style-type: none"> 1. Hole or air leak in inlet line 2. Vertical lift too high 3. Insufficient inlet pressure or suction head 4. Clogged foot valve or strainer 	<ol style="list-style-type: none"> 1. Repair or replace inlet line. Use thread tape and pipe sealing compound 2. Reduce vertical lift, install foot valve and prime 3. Increase inlet pressure by adding more water to tank or increasing back pressure 4. Inspect foot valve and/or strainer for debris, and remove
D. Pump vibrates and/or makes excessive noise	<ol style="list-style-type: none"> 1. Mounting plate or foundation not rigid enough 2. Foreign material in pump 3. Impeller damaged 	<ol style="list-style-type: none"> 1. Reinforce plate or foundation 2. Disassemble pump and clean 3. Replace impeller
E. Pump will not start or run	<ol style="list-style-type: none"> 1. Motor wired incorrectly 2. Blown fuse or open circuit breaker 3. Loose or broken wiring 4. Stone or foreign object lodged in impeller 5. Motor overheated 	<ol style="list-style-type: none"> 1. Check wiring diagram 2. Replace fuse or close circuit breaker 3. Tighten connections, replace broken wiring 4. Disassemble pump and remove foreign object 5. Allow unit to cool, restart after cooling
F. Pump loses prime.	<ol style="list-style-type: none"> 1. Clogged foot valve or strainer 2. Worn or broken foot valve 3. Hole or air leak in inlet line 	<ol style="list-style-type: none"> 1. Inspect foot valve and/or strainer for debris, and remove. 2. Inspect and replace 3. Repair or replace inlet line. Use thread tape and pipe sealing compound

REPLACEMENT PARTS LIST

To order parts, call 1-800-742-5044

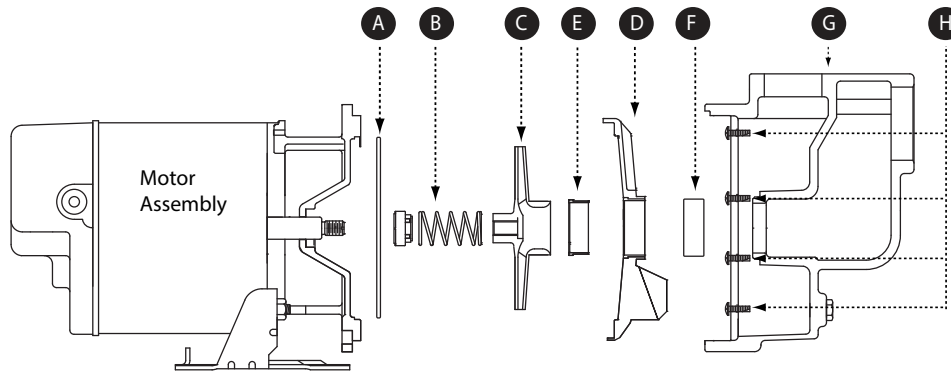

		HP	1	1-1/2	2
ITEM	SINGLE PHASE	MODEL NO.	SP10P1	SP15P1	SP20P1
	DESCRIPTION	PART NO.			
A	Ring, Square Cut	132429	1	1	1
B	Seal, Rotary and Ceramic (with Spring)	131100	1	1	1
C	Impeller		021280	134138	134138
D	Diffuser	132425	1	1	1
E	Diffuser Insert	134240	1	1	1
F	Rubber Diffuser	132428	1	1	1
G	Pump Body	023115	1	1	1
H*	Hex Hd. Cap Screws 3/8 in. x 3/4 in.	*	4	4	4

(*) Standard hardware item
 NOTE: Motor assembly not available as a replacement part.

PRODUCT SPECIFICATIONS

Model #	HP	Suction Lift (Ft.)	Discharge Pressure (PSI)							Shut Off Pressure @ 0 Lift (PSI)	Suction Pipe	Discharge Pipe
			15	20	25	30	35	40	45			
			Capacity - U.S. Gallons per Minute									
SP10P1 EL10P1	1	5	65	61	53	44	32			39	2 in.	1-1/2 in.
		10	64	58	49	39	24					
		15	62	55	45	34						
		20	59	51	41	28						
		25	56	46	36	2						
SP15P1 EL15P1	1-1/2	5	66	63	59	54	48	40	8	45	2 in.	1-1/2 in.
		10	64	61	57	52	45	28				
		15	63	60	55	49	41	15				
		20	62	58	53	46	32					
		25	60	56	50	42	21					
SP20P1 EL20P1	2	5	70	68	65	62	56	46	24	48	2 in.	1-1/2 in.
		10	69	66	63	60	52	39	6			
		15	68	65	62	57	47	27				
		20	67	64	60	53	41	13				
		25	65	62	58	48	30					

Max. Case Pressure: 100 PSI