

**Packaged Systems**

The Laundry Tray system is designed for above the floor "grey water" sump applications. Typical uses include laundry trays, wet bars, dehumidifiers, water softeners and air conditioner condensation. Manufactured with high quality polyethylene resins and tested to industry standards. The pre-assembled system comes complete with pump, tank, 1½" PVC discharge pipe and check valve (valve supplied loose).

**FEATURES:**

- All components are durable, corrosion-resistant polyethylene.
- Box and cover have a matching textured finish.
- 1-1/2" threaded "spin weld" insert for the inlet.
- Grommet discharge, vent and cord seals.
- Accommodates 1-1/2" discharge piping.
- Stainless steel bolts and encapsulated aluminum inserts
- Large 11 gallon capacity.
- 1/8" thick black closed cell foam gasket.
- Size: 12" x 16" x 14"
- Wall thickness 3/16"
- Package weight 26 lbs. (Includes pump)

MODEL	PART NO.	PUMP MODEL	PART NO.
SP33LT	112900	SP33VF	112551

See Section A pages 3 and 4 for additional pump data.  
See Section E for basin only.

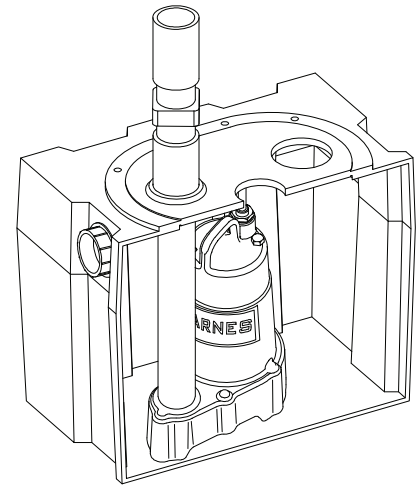

**Series: SP33LT, 60Hz**  
**P/N: 112900**

**DESCRIPTION:**

GENERAL PURPOSE PUMP FOR RESIDENTIAL AND LIGHT INDUSTRIAL SUMP APPLICATIONS



**WARNING:**

CANCER AND REPRODUCTIVE HARM -  
WWW.P65WARNINGS.CA.GOV

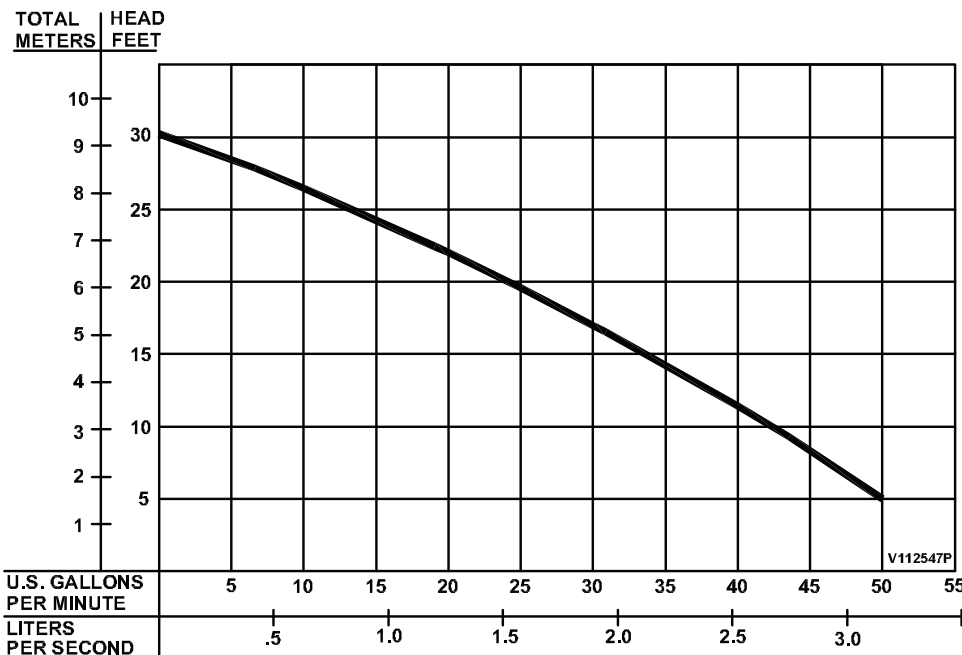

Testing is performed with water specific gravity of 1.0 @ 68°F (20°C), other fluids may vary performance

# Series SP33LT

Laundry Tray System

# BARNES®

Professional Plumbing

www.cranepumps.com

## Packaged Systems

inches  
(mm)

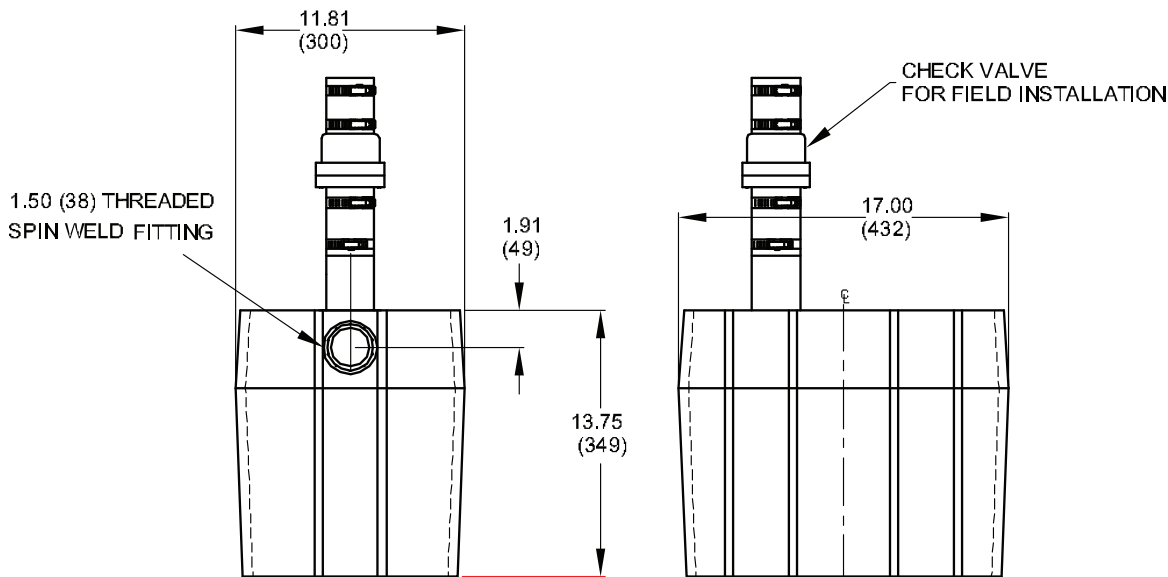
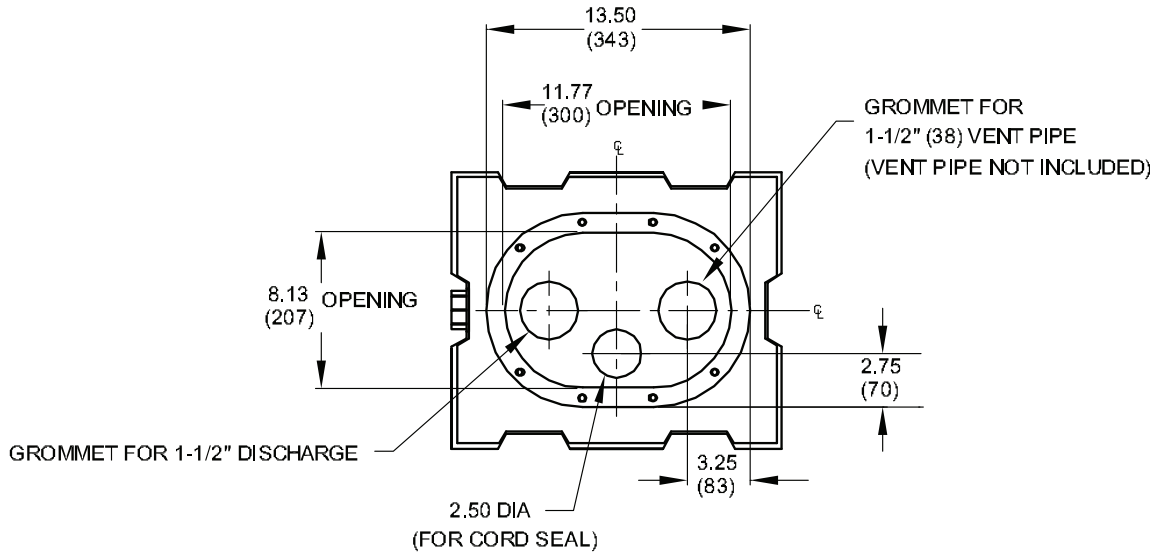

### IMPORTANT !

- 1.) PUMP MAY BE OPERATED "DRY" FOR EXTENDED PERIODS WITHOUT DAMAGE TO MOTOR AND/OR SEALS.
- 2.) INSTALLATIONS SUCH AS DECORATIVE FOUNTAINS OR WATER FEATURES PROVIDED FOR VISUAL ENJOYMENT MUST BE INSTALLED IN ACCORDANCE WITH THE NATIONAL ELECTRIC CODE ANSI/NFPA 70 AND/OR THE AUTHORITY HAVING JURISDICTION. THIS PUMP IS NOT INTENDED FOR USE IN SWIMMING POOLS, RECREATIONAL WATER PARKS, OR INSTALLATIONS IN WHICH HUMAN CONTACT WITH PUMPED MEDIA IS A COMMON OCCURRENCE.

SECTION B  
PAGE 4  
DATE 3/14

# CRANE®

A Crane Co. Company

## PUMPS & SYSTEMS

USA: (937) 778-8947 • Canada: (905) 457-6223 • International: (937) 615-3598