

Submersible Grinder Pumps

Specifications:

DISCHARGE	1¼" NPT, Vertical, Bolt-on Flange
LIQUID TEMPERATURE	160°F (71°C) Intermittent
VOLUTE	Cast Iron ASTM A-48, Class 30.
MOTOR HOUSING	Cast Iron ASTM A-48, Class 30.
SEAL PLATE	Cast Iron ASTM A-48, Class 30.
IMPELLER: Design	12 Vane, Vortex, With Pump Out Vanes On Back Side. Dynamically Balanced, ISO G6.3.
Material	Cast Iron
SHREDDING RING	Hardened 440C Stainless Steel Rockwell® C-55.
CUTTER	Hardened 440C Stainless Steel, Rockwell® C-55.
SHAFT	416 Stainless Steel
SQUARE RINGS	Buna-N
HARDWARE	300 Series Stainless Steel
PAINT	Air Dry Enamel.
SEAL: Design	Tandem Mechanical, Oil Filled Reservoir.
Material	Rotating Faces - Carbon Stationary Faces - Ceramic Elastomer - Buna-N Hardware - 300 Series Stainless
CORD ENTRY	30 ft. (9.1 m) Std. Cord. Custom Molded Quick Connect, for Sealing and Strain Relief
CORD	CSA/UL Approved 12/4 Type SOW.
UPPER BEARING:	
Design	Single Row, Ball, Oil Lubricated
Load	Radial
INTERMEDIATE BEARING:	
Design	Single Row, Ball, Oil Lubricated
Load	Radial & Thrust
LOWER BEARING:	
Design	Sleeve, Oil Lubrication:
Load	Radial
MOTOR: Design	NEMA L-Single Phase, (SGVF2022L, SGVH2022L, SGVF2002L or SGVH2002L, includes overload protection in the motor). NEMA B-Three Phase Torque Curve. Oil-Filled, Squirrel Cage Induction Class B.
Insulation	Class B.
SINGLE PHASE	Capacitor Start/Capacitor Run. Includes overload protection in the motor. Requires Barnes® Starter or Control Panel which Includes Capacitors, or Capacitor pack.
THREE PHASE	Dual Voltage 240/480; Requires Overload Protection to be Included in control panel.
OPTIONAL EQUIPMENT	Seal Material, Impeller Trims, Cord Length. Moisture Sensors, Moveable Fitting, Leg Kit P/N: 108339.
RECOMMENDED:	
Accessories	Break Away Fitting (BAF) Check Valve Control Panel
Seal Kit PN	113299
Service Kit PN	115946

SGV³
CENTRIFUGAL GRINDER PUMPS

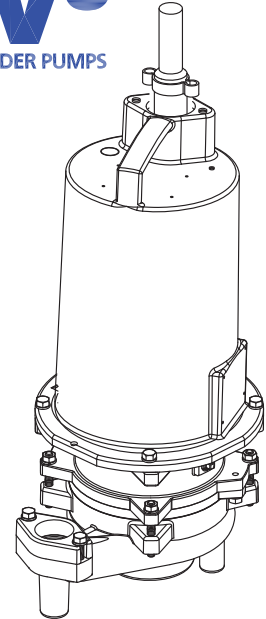

Series: SGVF & SGVH 2HP, 3450RPM, 60Hz High-Flow and High Head

Sample Specifications: Section 3 Page 8.

DESCRIPTION:

THE GRINDER PUMP IS DESIGNED TO REDUCE DOMESTIC, COMMERCIAL, INSTITUTIONAL AND LIGHT INDUSTRIAL SEWAGE TO A FINELY GROUND SLURRY.



WARNING:

CANCER AND REPRODUCTIVE HARM -
WWW.P65WARNINGS.CA.GOV



Series SGVF & SGVH

Recessed Vortex

BARNES®

www.cranepumps.com

Submersible Grinder Pumps

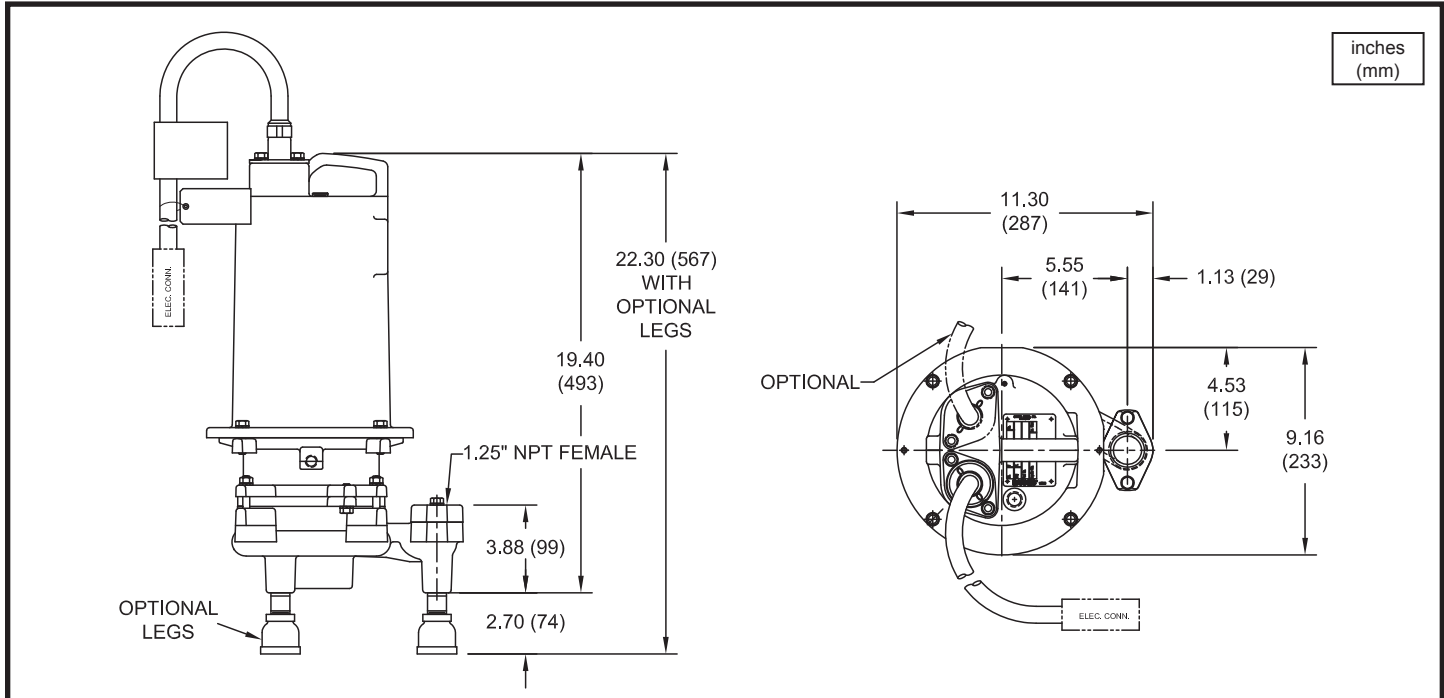

inches
(mm)

MODEL NO	PART NO	HP	VOLT	PH/Hz	RPM (Nom)	NEMA START CODE	FULL LOAD AMPS	LOCKED ROTOR AMPS	CORD SIZE	CORD TYPE	CORD O.D. ± .02 (.5) in (mm)
HIGH-FLOW											
SGVF2002L*	110614	2	200	1 / 60	3450	F	17.0	53.0	12/4	SOW	.67 (17)
SGVF2022L	110609	2	240	1 / 60	3450	H	15.0	53.8	12/4	SOW	.67 (17)
SGVF2062L	110610	2	200	3 / 60	3450	J	11.0	42.0	12/4	SOW	.67 (17)
SGVF2032L	110611	2	240	3 / 60	3450	J	9.0	36.0	12/4	SOW	.67 (17)
SGVF2042L	110612	2	480	3 / 60	3450	J	4.0	18.0	12/4	SOW	.67 (17)
SGVF2052L	110613	2	600	3 / 60	3450	J	3.2	14.4	12/4	SOW	.67 (17)
HIGH-HEAD											
SGVH2002L*	110620	2	200	1 / 60	3450	F	17.0	53.0	12/4	SOW	.67 (17)
SGVH2022L	110615	2	240	1 / 60	3450	H	15.0	53.8	12/4	SOW	.67 (17)
SGVH2062L	110616	2	200	3 / 60	3450	J	11.0	42.0	12/4	SOW	.67 (17)
SGVH2032L	110617	2	240	3 / 60	3450	J	9.0	36.0	12/4	SOW	.67 (17)
SGVH2042L	110618	2	480	3 / 60	3450	J	4.0	18.0	12/4	SOW	.67 (17)
SGVH2052L	110619	2	600	3 / 60	3450	J	3.2	14.4	12/4	SOW	.67 (17)

Optional - Temperature sensor cord for all models is 14/3 SOW, 0.55 (14mm) ± .02 (.51mm) O.D. (Not used on SGVF2022L, SGVH2022L, SGVF2002L or SGVH2002L).

Optional - Moisture and Temperature sensor cord for all models is 18/5 SOW, 0.49 (12.4mm) ± .02 (.51mm) O.D., replaces Temperature sensor cord. (*) This pump is **NOT** CSA listed

IMPORTANT !

- 1.) MODELS SGVF2002L AND SGVH2002L ARE **NOT** CSA LISTED
- 2.) PUMP MAY BE OPERATED "DRY" FOR EXTENDED PERIODS WITHOUT DAMAGE TO MOTOR AND/OR SEALS.
- 3.) INSTALLATIONS SUCH AS DECORATIVE FOUNTAINS OR WATER FEATURES PROVIDED FOR VISUAL ENJOYMENT MUST BE INSTALLED IN ACCORDANCE WITH THE NATIONAL ELECTRIC CODE ANSI/NFPA 70 AND/OR THE AUTHORITY HAVING JURISDICTION. THIS PUMP IS NOT INTENDED FOR USE IN SWIMMING POOLS, RECREATIONAL WATER PARKS, OR INSTALLATIONS IN WHICH HUMAN CONTACT WITH PUMPED MEDIA IS A COMMON OCCURRENCE.

SECTION 3B
PAGE 2
DATE 12/18

CRANE
A Crane Co. Company

PUMPS & SYSTEMS

USA: (937) 778-8947 • Canada: (905) 457-6223 • International: (937) 615-3598

Submersible Grinder Pumps

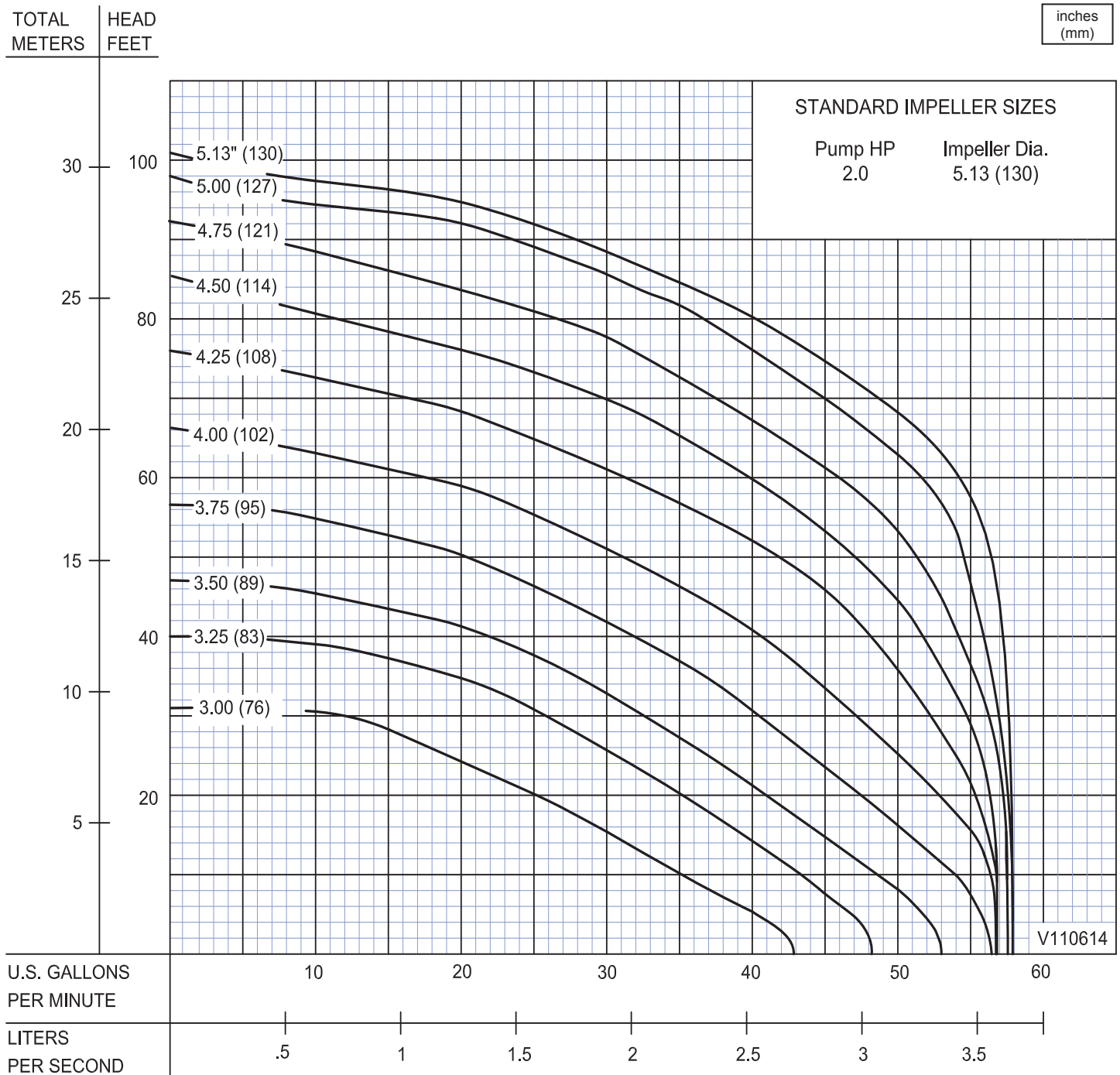

Testing is performed with water, specific gravity 1.0 @ 68° F @ (20°C), other fluids may vary performance

Series SGVH

Performance Curve
2HP, 3450RPM, 60Hz, High-Head

BARNES®

www.cranepumps.com

Submersible Grinder Pumps

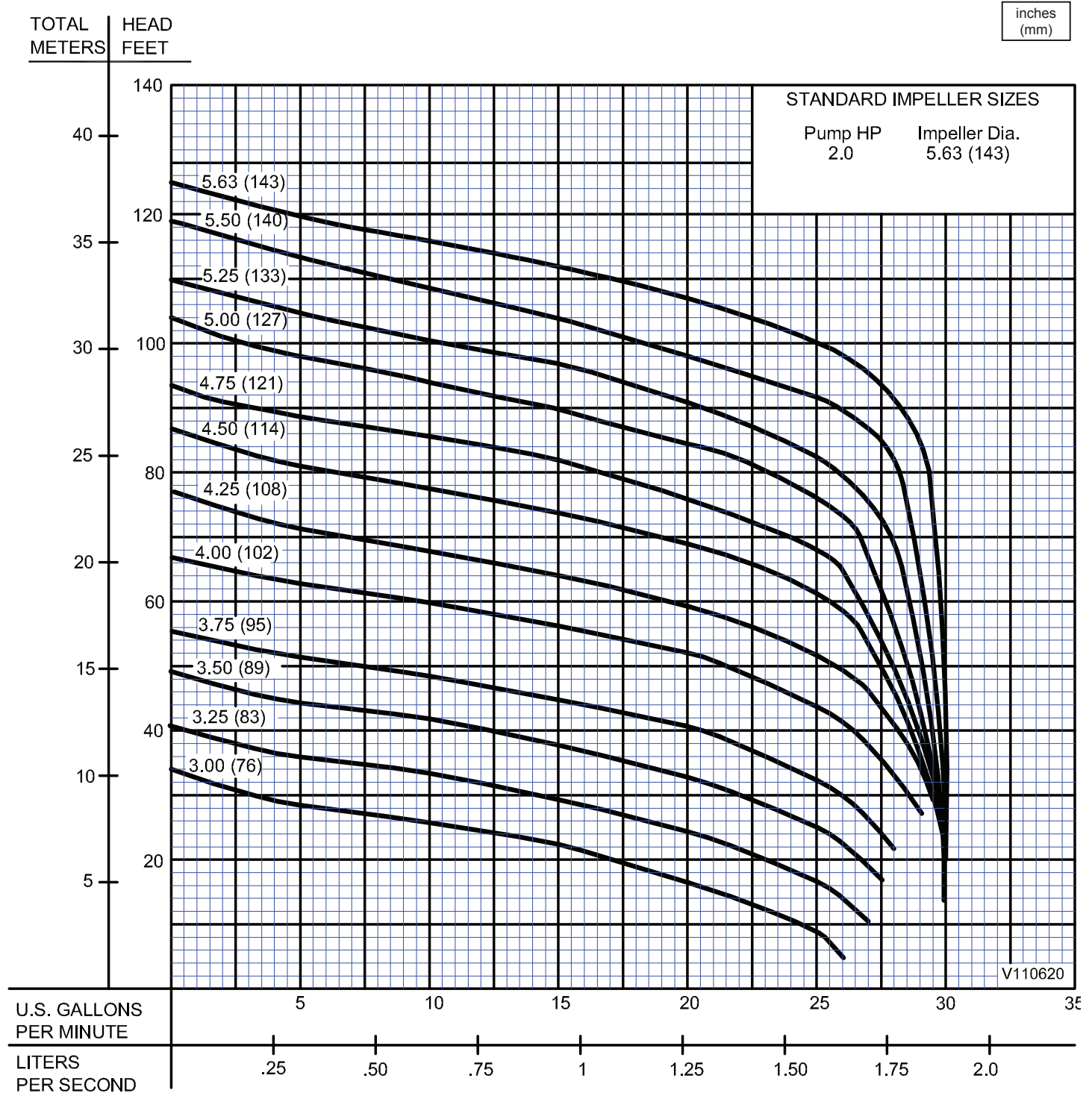

Testing is performed with water, specific gravity 1.0 @ 68° F @ (20°C), other fluids may vary performance

SECTION 3B
PAGE 4
DATE 11/03

CRANE®

A Crane Co. Company

PUMPS & SYSTEMS

USA: (937) 778-8947 • Canada: (905) 457-6223 • International: (937) 615-3598