

# BARNES<sup>®</sup>

## INSTALLATION MANUAL Submersible Grinder Pump

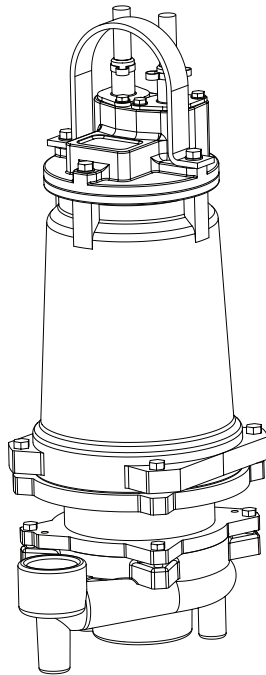
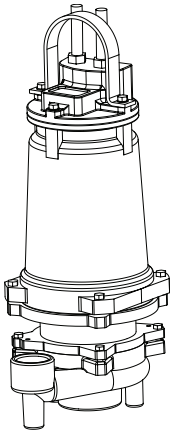

**Series: SGV  
3, 5, 7.5HP, 60Hz,  
3450RPM**

**1.7, 2.8, 4.2HP, 50Hz,  
2850RPM**

**SGV<sup>3</sup>**  
CENTRIFUGAL GRINDER PUMPS

**IMPORTANT!**

*Read all instructions in this manual before operating pump.  
As a result of Crane Pumps & Systems, Inc., constant product improvement program,  
product changes may occur. As such Crane Pumps & Systems reserves the right to  
change product without prior written notification.*

**CRANE**<sup>®</sup>

A Crane Co. Company

### PUMPS & SYSTEMS

420 Third Street  
Piqua, Ohio 45356  
Phone: (937) 778-8947  
Fax: (937) 773-7157  
www.cranepumps.com

83 West Drive, Bramton  
Ontario, Canada L6T 2J6  
Phone: (905) 457-6223  
Fax: (905) 457-2650



Form No. 113317-Rev. Y

# ATTENTION SAFETY FIRST!

Please Read This Before Installing Or Operating Pump.  
This information is provided for **SAFETY and to PREVENT EQUIPMENT PROBLEMS**. To help recognize this information, observe the following symbols:



**IMPORTANT!** Warns about hazards that can result in personal injury or indicates factors concerned with assembly, installation, operation, or maintenance which could result in damage to the machine or equipment if ignored.

**CAUTION !** Warns about hazards that can or will cause minor personal injury or property damage if ignored. Used with symbols below.

**WARNING !** Warns about hazards that can or will cause serious personal injury, death, or major property damage if ignored. Used with symbols below.



*Hazardous fluids can cause fire or explosions, burns or death could result.*



*Extremely hot - Severe burns can occur on contact.*



*Biohazard can cause serious personal injury.*



*Hazardous fluids can Hazardous pressure, eruptions or explosions could cause personal injury or property damage.*



*Rotating machinery Amputation or severe laceration can result.*



*Hazardous voltage can shock, burn or cause death.*

Only qualified personnel should install, operate and repair pump. Any wiring of pumps should be performed by a qualified electrician.



**WARNING !** - To reduce risk of electrical shock, pumps and control panels must be properly grounded in accordance with the National Electric Code (NEC) or the Canadian Electrical Code (CEC) and all applicable state, province, local codes and ordinances.

**WARNING!** - To reduce risk of electrical shock, always disconnect the pump from the power source before handling or servicing. Lock out power and tag.

Prevent large articles of clothing, large amounts of chemicals, other materials or substances such as are uncommon in domestic sewage from entering the system.

During power black-outs, minimize water consumption at the home(s) to prevent sewage from backing up into the house.

Always keep the shut-off valve completely open when system is in operation (unless advised otherwise by the proper authorities). Before removing the pump from the basin, be sure to close the shut-off valve. (This prevents backflow from the pressure sewer.)

Keep the control panel locked or confined to prevent unauthorized access to it.

If the pump is idle for long periods of time, it is advisable to start the pump occasionally by adding water to the basin.



**CAUTION!** Pumps build up heat and pressure during operation-allow time for pumps to cool before handling or servicing.



**WARNING! - DO NOT** pump hazardous materials (flammable, caustic, etc.) unless the pump is specifically designed and designated to handle them.

Do not block or restrict discharge hose, as discharge hose may whip under pressure.



**WARNING! - DO NOT** wear loose clothing that may become entangled in the impeller or other moving parts.

**WARNING!** - Keep clear of suction and discharge openings. DO NOT insert fingers in pump with power connected.

Make sure lifting handles are securely fastened each time before lifting. Do not operate pump without safety devices in place. Always replace safety devices that have been removed during service or repair.

Do not exceed manufacturers recommendation for maximum performance, as this could cause the motor to overheat.

Secure the pump in its operating position so it can not tip over, fall or slide.

Cable should be protected at all times to avoid punctures, cut, bruises and abrasions - inspect frequently.



Never handle connected power cords with wet hands.

To reduce risk of electrical shock, all wiring and junction connections should be made per the NEC or CEC and applicable state or province and local codes. Requirements may vary depending on usage and location.



Submersible Pumps are not approved for use in swimming pools, recreational water installations, decorative fountains or any installation where human contact with the pumped fluid is common.

Do not remove cord and strain relief. Do not connect conduit to pump.



Products Returned Must Be Cleaned, Sanitized, Or Decontaminated As Necessary Prior To Shipment, To Insure That Employees Will Not Be Exposed To Health Hazards In Handling Said Material. All Applicable Laws And Regulations Shall Apply.

Bronze/brass and bronze/brass fitted pumps may contain lead levels higher than considered safe for potable water systems. Lead is known to cause cancer and birth defects or other reproductive harm. Various government agencies have determined that leaded copper alloys should not be used in potable water applications. For non-leaded copper alloy materials of construction, please contact factory.



**IMPORTANT!** - Crane Pumps & Systems, Inc. is not responsible for losses, injury, or death resulting from a failure to observe these safety precautions, misuse or abuse of pumps or equipment.



A pump that is intended to pump sewage or effluent shall be installed in a tank that is vented in accordance with local plumbing codes and is not classified as hazardous in accordance with the National Electrical Code, ANSI/NFPA 70 unless it is specifically marked for such use.

Other brand and product names are trademarks or registered trademarks of their respective holders.

® Barnes is a registered trademark of Crane Pumps & Systems, Inc.

2001, 2002, 2003, 7/2004, 11/2004, 7/05, 8/05, 11/05, 1/06, 6/06, 9/06, 11/06

# USER GUIDE

## USER GUIDE

Congratulations on your purchase of a Barnes *UltraGRIND™* grinder pump system. With proper care and by following a few simple guidelines your grinder pump will give you many years of dependable service.

### Use and Care

The *UltraGRIND* grinder pump station is designed to handle routine, domestic sewage. Solid waste materials should be thrown in the trash. While your station is capable of accepting and pumping a wide range of materials, regulatory agencies advise that the following items should not be introduced into any sewer either directly or through a kitchen waste disposal:

- Glass
- Metal
- Diapers
- Socks, rags or cloth
- Plastic objects (e.g., toys, utensils, etc.)
- Sanitary napkins or tampons

In addition you must **NEVER** introduce into any sewer:

- Explosives
- Flammable Material
- Lubricating Oil and/or Grease
- Strong Chemicals
- Gasoline

### General Information

Your home wastewater disposal service is part of a low pressure sewer system. The key element in this system is the Barnes *UltraGRIND* grinder pump station. The basin collects all wastewater from the house. The solids in the sewage are then ground to a small size suitable for pumping in the slurry.

The grinder pump generates sufficient pressure to pump this slurry from your home to the wastewater plant.

### Power Failure

Your grinder pump cannot dispose of wastewater or provide an alarm signal without electrical power. If electrical power service is interrupted, keep water usage to a minimum.

### Warranty

Your grinder pump is furnished with a warranty against defects in material or workmanship. A properly completed

Start-Up/Warranty Registration form must be on file at the Barnes factory in order to activate your warranty. In addition your pump must be installed in accordance with the installation instructions.

If you have a claim under the provisions of the warranty, contact your local Barnes Distributor.

When contacting your representative for service, please include your station serial number, pump model number, and pump serial number.

For future reference, record the following information:

Station Serial No: \_\_\_\_\_

Pump Model No: \_\_\_\_\_

Pump Serial No: \_\_\_\_\_

Local Distributor: \_\_\_\_\_

Distributor Telephone: \_\_\_\_\_

## PUMP SPECIFICATIONS:

<b>DISCHARGE</b> .....	2" NPT, Vertical
<b>LIQUID TEMPERATURE</b> ....	104°F (40°C) Continuous
<b>MOTOR HOUSING</b> .....	Cast Iron ASTM A-48, Class 30
<b>VOLUTE</b> .....	Cast Iron ASTM A-48, Class 30
<b>SEAL PLATE</b> .....	Cast Iron ASTM A-48, Class 30
<b>IMPELLER:</b>	
<i>Design</i> .....	12 vane, vortex, with pump out vanes on back side. Dynamically balanced, ISO G6.3
<i>Material</i> .....	Cast Iron
<b>SHREDDING RING</b> .....	Hardened 440C Stainless Steel Rockwell C-55
<b>CUTTER</b> .....	Hardened 440C Stainless Steel Rockwell C-55
<b>SHAFT</b> .....	416 Stainless Steel
<b>SQUARE RINGS</b> .....	Buna-N
<b>HARDWARE</b> .....	300 Series Stainless Steel
<b>PAINT</b> .....	Air dry enamel, top coat
<b>SEAL</b> <i>Design</i> .....	Tandem Mechanical, oil filled reservoir
<i>Material</i> .....	Rotating Faces - Carbon Stationary Faces - Ceramic Elastomer - Buna-N Hardware - 300 series stainless steel
<b>CORD ENTRY</b>	
<b>SGV5002L &amp; SGV5022L:</b> .....	30Ft. (9m) Std. cord. Pressure grommet for sealing and strain relief.
<i>All the rest:</i> .....	30Ft. (9m) Cord, Custom Molded Quick Connected for sealing and strain relief.
<b>CORD</b> .....	CSA/UL Approved 10/4, 8/4, 6/4 Type SOW (or SOOW)

<b>SPEED</b> .....	3450 RPM, 60Hz (nominal)
<b>UPPER BEARING:</b>	
<i>Design</i> .....	Single Row, Ball, Oil Lubricated
<i>Load</i> .....	Radial
<b>INTERMEDIATE BEARING:</b>	
<i>Design</i> .....	Single Row, Ball, Oil Lubricated
<i>Load</i> .....	Radial & Thrust
<b>LOWER BEARING:</b>	
<i>Design</i> .....	Sleeve, Oil Lubricated
<i>Load</i> .....	Radial
<b>MOTOR:</b> <i>Design</i>	NEMA L, Single phase, NEMA B, Three Phase Torque Curve, Oil Filled, Squirrel Cage Induction
<i>Insulation</i> .....	Class F
<b>SINGLE PHASE</b> .....	Capacitor start/capacitor run. Requires overload protection to be included in control panel, Requires Barnes Starter or Control panel, which includes capacitors, or capacitor pack.
<b>THREE PHASE</b> .....	Dual voltage 240/480 60Hz, Requires overload protection to be included in control panel
<b>NOISE EMISSION</b> .....	Max. in Air 20dB-A, Submerged 14dB-A
<b>SUBMERGENCE</b> .....	Max Depth 30Ft. (9m)
<b>OPTIONAL EQUIPMENT</b> ....	Seal Material, Additional Cord, Impeller trims, Moisture sensors (requires relay in panel), Moveable Fitting

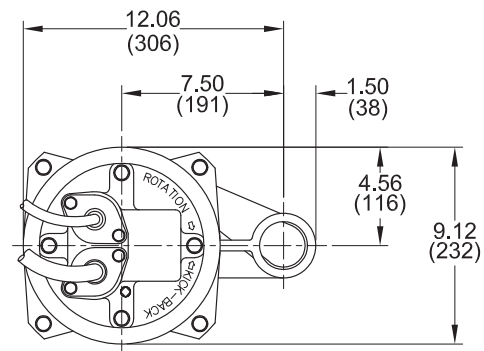
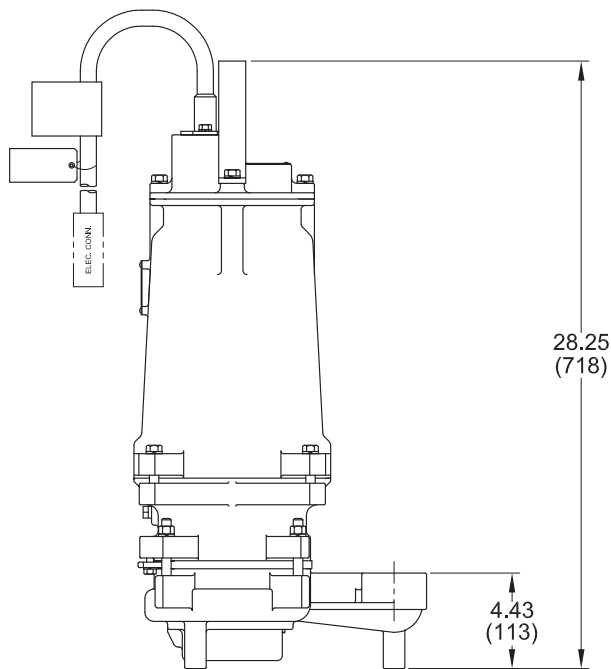

FIGURE SHOWN WITHOUT LIFTING BAIL

MODEL NO	PUMP WEIGHT lbs. (kg)	HP	VOLT/ PH	Hz	RPM (Nom)	NEMA START CODE	FULL LOAD AMPS	LOCKED ROTOR AMPS	CORD SIZE	CODE TYPE	CORD O.D. ± .02 (.5) in (mm)	WINDING RESISTANCE MAIN-START	
												Emerson	Franklin
SGV3072L	198 (89.8)	3	200/240/1	60	3450	G	25.2/21.7	86/75	10/4	SOW	0.75 (19)	0.52-4.49	2.88-4.36
SGV3062L	198 (89.8)	3	200/3	60	3450	J	17.0	65.0	10/4	SOW	0.75 (19)	1.43	0.96
SGV3032L	198 (89.8)	3	240/3	60	3450	K	14.5	62.0	10/4	SOW	0.75 (19)	1.93	1.23
SGV3042L	198 (89.8)	3	480/3	60	3450	K	7.2	31.0	10/4	SOW	0.75 (19)	7.3	4.9
SGV3052L	198 (89.8)	3	600/3	60	3450	J	5.6	22.6	10/4	SOW	0.75 (19)	12.14	----
SGV5002L	198 (89.8)	5	200/1	60	3450	F	42.0	134.0	6/4	SOW	1.03 (26)	0.5-3.2	----
SGV5022L	198 (89.8)	5	240/1	60	3450	H	39.0	136.0	8/4	SOW	0.93 (24)	0.49-2.18	----
SGV5062L	198 (89.8)	5	200/3	60	3450	K	25.0	122.0	10/4	SOW	0.75 (19)	0.65	0.6
SGV5032L	198 (89.8)	5	240/3	60	3450	L	21.9	120.0	10/4	SOW	0.75 (19)	0.84	0.82
SGV5042L	198 (89.8)	5	480/3	60	3450	L	11.0	60.0	10/4	SOW	0.75 (19)	3.37	3.28
SGV5052L	198 (89.8)	5	600/3	60	3450	L	8.8	46.0	10/4	SOW	0.75 (19)	5.09	5.04
SGV7532L	202 (91.6)	7.5	240/3	60	3450	J	22.3	136.0	10/4	SOW	0.75 (19)	---	0.47
SGV7542L	202 (91.6)	7.5	480/3	60	3450	J	11.2	68.0	10/4	SOW	0.75 (19)	---	1.88
SGV7552L	202 (91.6)	7.5	600/3	60	3450	G	8.2	45.0	10/4	SOW	0.75 (19)	3.51	----
SGV30Z2L	198 (89.8)	1.7	380/415/3	50	2850	J	6.0	25.8	10/4	SOW	0.75 (19)	7.3	4.9
SGV50Z2L	198 (89.8)	2.8	380/415/3	50	2850	N	9.2	50.0	10/4	SOW	0.75 (19)	3.37	3.28
SGV75Z2L	202 (91.6)	4.2	380/415/3	50	2850	K	9.3	57.0	10/4	SOW	0.75 (19)	---	1.88

Winding Resistance ± 5%, measured from terminal block. Pump rated for operation at ± 10% voltage at motor.

**Optional** - Temperature sensor Only, cord for SGV5002L & SGV5022L is 14/2 SOW, 0.55 ± .02 O.D.

**Optional** - Temperature sensor Only, cord for all other models is 14/3 SOW, 0.55 ± .02 O.D.

**Optional** - Moisture and Temperature sensor cord for all models is 18/5 SOW, 0.47 ± .02 O.D., replaces Temperature sensor cord.

### Recommended Breaker & Heater Sizes

Model No.	HP	Ph	Volts	Breaker Size	Heater Size	Voltage Relay	Start Capacitor	Run Capacitor
SGV3072L	3	1	200/240	50 AMP	K-64	MARS 66/64	257 mfd - 220 volts	20 mfd - 370 volts
SGV3062L	3	3	200	40 AMP	K-56	N/R	N/R	N/R
SGV3032L	3	3	240	30 AMP	K-54	N/R	N/R	N/R
SGV3042L	3	3	480	15 AMP	K-41	N/R	N/R	N/R
SGV3052L	3	3	600	15 AMP	K-37	N/R	N/R	N/R
SGV5002L	5	1	200	100 AMP	K-73	MARS 64	189-227 mfd - 220 volts	40 mfd - 370 volts
SGV5022L	5	1	240	80 AMP	K-70	MARS 64	189-227 mfd - 220 volts	40 mfd - 370 volts
SGV5062L	5	3	200	50 AMP	K-63	N/R	N/R	N/R
SGV5032L	5	3	240	50 AMP	K-62	N/R	N/R	N/R
SGV5042L	5	3	480	20 AMP	K-50	N/R	N/R	N/R
SGV5052L	5	3	600	20 AMP	K-49	N/R	N/R	N/R
SGV7532L	7.5	3	240	50 AMP	K-67	N/R	N/R	N/R
SGV7542L	7.5	3	480	30 AMP	K-54	N/R	N/R	N/R
SGV7552L	7.5	3	600	20 AMP	K-50	N/R	N/R	N/R
SGV30Z2L	1.7	3	380/415/3	15 AMP	K-41	N/R	N/R	N/R
SGV50Z2L	2.8	3	380/415/3	20 AMP	K-50	N/R	N/R	N/R
SGV75Z2L	4.2	3	380/415/3	30 AMP	K-54	N/R	N/R	N/R

NOTE: Factory recommended heater sizes may vary depending on pump station requirements.

N/R = Not Required.

## RECEIVING/UNPACKING:

Upon receiving the pump, it should be inspected for damage or shortages. If damage has occurred, file a claim immediately with the company that delivered the pump. Unpack pump and record pump serial and model number before installing. If the manual is removed from the packaging, do not lose or misplace.

## STORAGE:

**Short Term-** For best results, pumps can be retained in storage, as factory assembled, in a dry atmosphere with constant temperatures for up to six (6) months.

**Long Term-** Any length of time exceeding six (6) months, but not more than twenty-four (24) months. The units should be stored in a temperature controlled area, a roofed over walled enclosure that provides protection from the elements (rain, snow, wind-blown dust, etc.), and whose temperature can be maintained between +40 deg. F and +120 deg. F. If extended high humidity is expected to be a problem, all exposed parts should be inspected before storage and all surfaces that have the paint scratched, damaged, or worn should be recoated with a air dry enamel paint. All surfaces should then be sprayed with a rust-inhibiting oil.

Pump should be stored in its original shipping container. On initial start up, rotate shaft by hand to assure seal and motor rotate freely. If it is required that the pump be installed and tested before the long term storage begins, such installation will be allowed provided:

- 1.) The pump is not installed under water for more than one (1) month.
- 2.) Immediately upon satisfactory completion of the test, the pump is removed, thoroughly dried, repacked in the original shipping container, and placed in a temperature controlled storage area.

## SERVICE CENTERS:

For the location of the nearest Barnes Service Center, check your Barnes representative or Crane Pumps & Systems, Inc., Service Department in Piqua, Ohio, telephone (937) 778-8947 or in Brampton, Ontario, Canada (905) 457-6223.

## INSTALLATION:

**Location** - The pump is designed to fit into your basin either by sliding down the rail assembly, suspended from the cover or by being mounted on a pump base.

**THIS PUMP MUST BE INSTALLED WITH A MINIMUM OF 3 INCHES AND A MAXIMUM OF 4.5 INCHES OF CLEARANCE UNDER THE PUMP FOR THE ENTRANCE OF SEWAGE SOLIDS.**

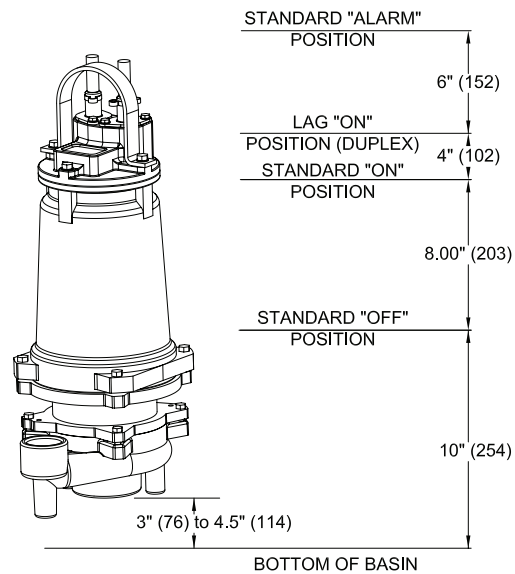

FIGURE 1 - L Series

**Discharge** - Assemble discharge piping or hose assembly (whichever is required by your application), to the pump. Discharge piping should be as short as possible. Both a check valve and a shut-off valve are required for each pump being used. The check valve is used to prevent backflow into the sump. Excessive backflow can cause flooding and/or damage to the pump. The shut-off valve is used to stop system flow during pump or check valve servicing.

**Package Systems-** Refer to manual supplied with basin package system.

## ELECTRICAL CONNECTIONS:

**Pump Cords** - The quick connect cord assembly mounted to the pump must **NOT** be modified in any way except for shortening to a specific application. Any supply cables connections between the pump and the control panel must be made in accordance with the National Electric Code or the Canadian Electric Code and all applicable state, province and local electric codes. It is recommended that a junction box, be mounted outside the sump or be of at least Nema 4 (EEMAC-4) construction if located within the wet well. **DO NOT USE THE POWER OR CONTROL CABLES TO LIFT PUMP!**

**Thermal Protection** The normally closed (N/C) over temperature sensor is embedded in the motor windings and will detect excessive heat in the event an overload condition occurs. The thermal sensor will trip when the windings become too hot and will automatically reset itself when the pump motor cools to a safe temperature. It is recommended that the thermal sensor be connected in series to an alarm device to alert the operator of an overtemperature condition and/or motor starter coil to stop pump.

In the event of an overtemperature, the source of this condition should be determined and rectified immediately. Thermal protection shall not be used as a motor overload device. A separate motor overload device must be provided in accordance with NEC codes. **DO NOT LET THE PUMP CYCLE OR RUN IF AN OVERLOAD CONDITION OCCURS!**

**Moisture Sensors: (Optional)** - A normally open (N/O) detector is installed in the pump seal chamber which will detect any moisture present. It is recommended that this detector be connected in series to an alarm device or the motor starter coil to alert the operator that a moisture detect has occurred. In the event of a moisture detect, check the individual moisture sensor probe leads for continuity, ( $\infty$  resistance = no moisture ) and the junction box/control box for moisture content. This situations may induce a false signal in the moisture detecting circuit. If none of the above tests prove conclusive, the pump(s) should be pulled and the source of the failure identified and repaired. **IF A MOISTURE DETECT HAS OCCURRED SCHEDULE MAINTENANCE AS SOON AS POSSIBLE.**

**Wire Size** - If additional cord is required consult a qualified electrician for proper wire size.

**CORD CONNECTIONS:** (Except 5002L & 5022L)

**Power/Control Cord**- Insert female end of cord plug into housing bore aligning alignment mark with hole in terminal block see Figure 2. Tighten bolts on compression flange until flush with motor housing.

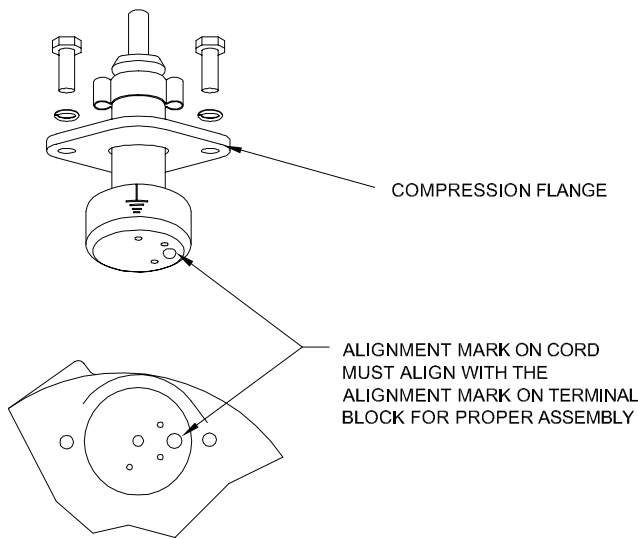

**SERVICE:**

**Lubrication:**

Anytime the pump is removed from operation, the cooling oil in the motor housing (10) should be checked visually for oil level and contamination.

**Checking Oil:**

**Motor Housing** - To check oil, set unit upright. Remove pipe plug (36) from motor housing (10). With a flashlight, visually inspect the oil in the motor housing (10) to make sure it is clean and clear, light amber in color and free from suspended particles. Milky white oil indicates the presence of water. Oil level should be just above the motor when pump is in vertical position.

**Testing Oil:**

- 1.) Place pump on it's side, remove pipe plug (36), from motor housing (10) and drain oil into a clean, dry container.
- 2.) Check oil for contamination using an oil tester with a range to 30 Kilovolts breakdown.
- 3.) If oil is found to be clean and uncontaminated (measuring above 15 KV. breakdown), refill the motor housing as per section "Replacing Oil".
- 4.) If oil is found to be dirty or contaminated (or measures below 15 KV. breakdown), the pump must be carefully inspected for leaks at the shaft seals (5) (40), cord assemblies (49, 50, 15, 16) , square rings (8), (14), (29) and pipe plugs, (36) before refilling with oil. To locate the leak, perform a pressure test as per section "Pressure Test". After leak is repaired, dispose of old oil properly, and refill with new oil as per section "Replacing Oil".

**Replacing Oil:**

**Motor Housing** - Drain all oil from motor housing and dispose of properly per Local and Environmental Standards. Set unit upright and refill with new cooling oil as per Table 1 (see parts list for amount). Fill to just above motor as an air space must remain in the top of the motor housing to compensate for oil expansion. Apply pipe thread compound to threads of pipe plug (36) then assemble to motor housing (10).

**Seal Chamber** - Drain all oil from seal chamber and dispose of properly per Local and Environmental Standards. Set unit on its side, with plug (36) upward, and refill with new oil as per Table 1 (see parts list for amount). Apply pipe thread compound to threads of pipe plug (36) and assemble to seal plate (6).

**Warning ! - Do not overfill oil. Overfilling of motor housing with oil can create excessive and dangerous hydraulic pressure which can destroy the pump and create a hazard. Overfilling oil voids warranty.**

TABLE 1 - COOLING OIL - Dielectric	
SUPPLIER	GRADE
BP	Enerpar SE100
Conoco	Pale Paraffin 22
Mobile	D.T.E. Oil Light
G & G Oil	Circulating 22
Imperial Oil	Voltesso-35
Shell Canada	Transformer-10
Texaco	Diala-Oil-AX
Woco	Premium 100

**Pressure Test:**

**Pumps that have been disassembled, Motor Housing -** If the pump has been disassembled, the oil should be drained before a pressure test, as described in section "Checking Oil". Remove pipe plug (36) from motor housing (10). Apply pipe sealant to pressure gauge assembly and tighten into hole (See Figure 3). Pressurize motor housing to 10 P.S.I. Use soap solution around the sealed areas and inspect joints for "air bubbles". If, after five minutes, the pressure is still holding constant, and no "bubbles" are observed, slowly bleed the pressure and remove the gauge assembly. Replace oil as described in section "Replacing Oil". If the pressure does not hold, then the leak must be located and repaired.

**Pumps that have NOT been disassembled, Motor Housing -** The pressure test may be done with the oil at its normal level. Remove pipe plug (36) from motor housing (10). Apply pipe sealant to pressure gauge assembly and tighten into hole (See Figure 3). Pressurize motor housing to 10 P.S.I. Use soap solution around the sealed areas above the oil level and inspect joints for "air bubbles". For sealed areas below the oil level, leaks will seep oil. If, after five minutes, the pressure is still holding constant, and no "bubbles"/oil seepage is observed, slowly bleed the pressure and remove the gauge assembly. If the pressure does not hold, then the leak must be located and repaired.

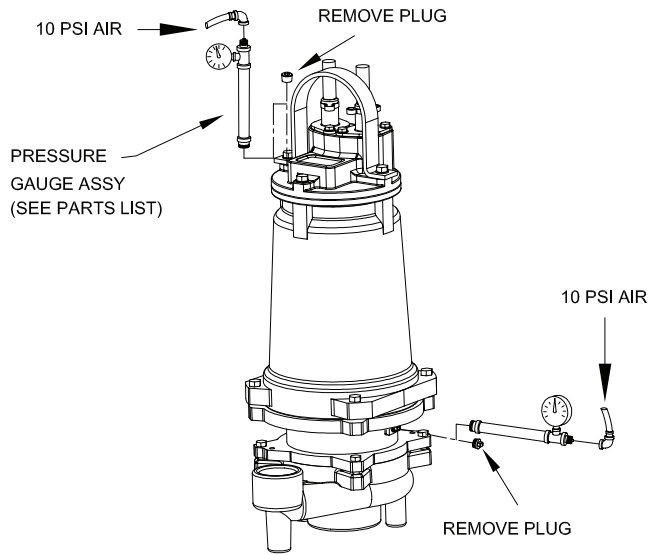

**FIGURE 3**

**CAUTION !** Pressure builds up extremely fast, increase pressure by "tapping" air nozzle. Too much pressure will damage seal. **DO NOT exceed 10 P.S.I.**

**Seal Chamber -** Set unit on its side with fill plug (36) downward, remove plug (36) and drain all oil from seal chamber. Apply pipe sealant to pressure gauge assembly and tighten into hole in seal plate (6). Pressurize seal chamber to 10 P.S.I. and check for leaks as outlined above.



**SGV5002L & SGV5022L ONLY**

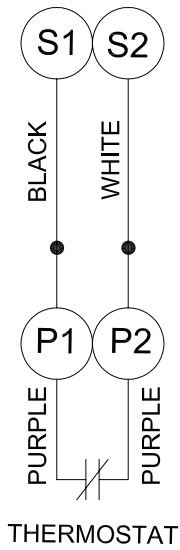
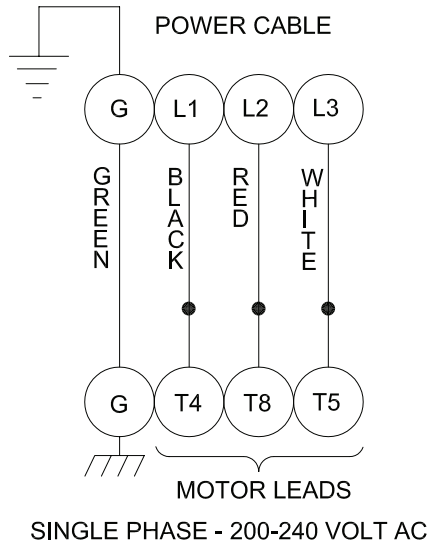

**CONTROL (Small Cable)  
Temperature Sensor**

**CONTROL**  
Small Cable

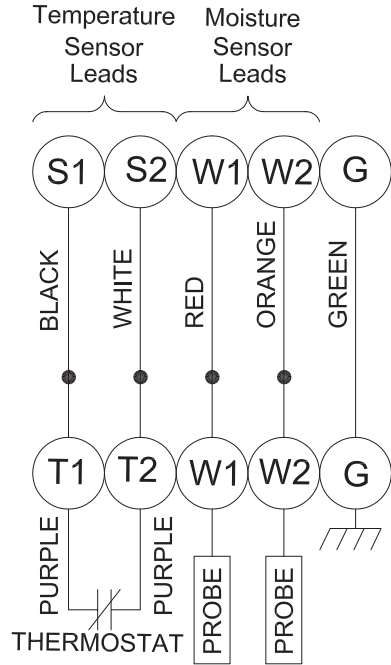

**CONTROL (Small Cable)  
Moisture & Temperature Sensors**

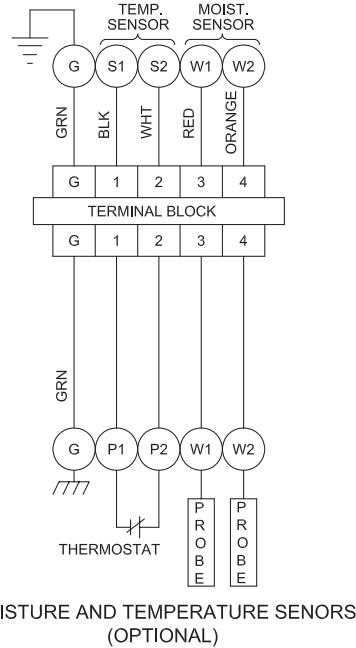
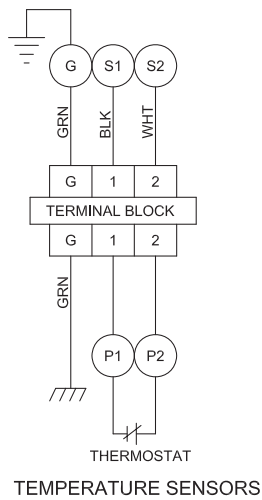
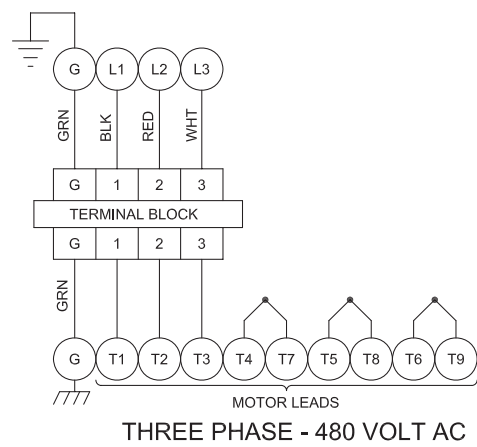
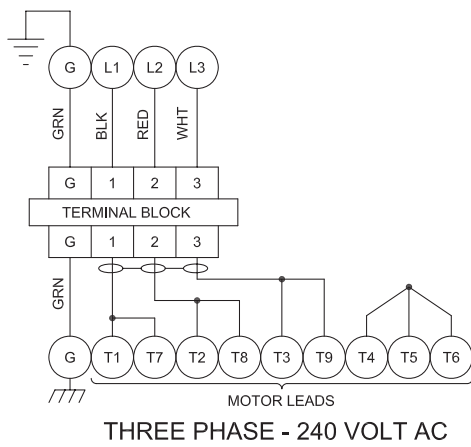
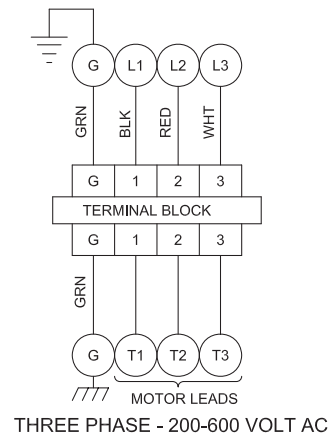
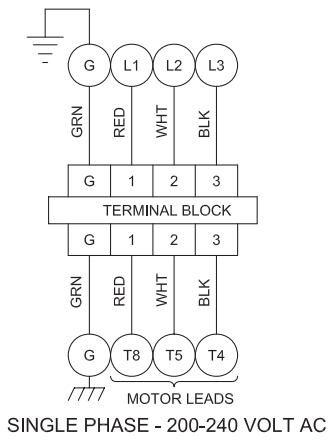

**ALL EXCEPT  
SGV5002L & SGV5022L**

200/240 VOLT  
1 PHASE  
60 HZ.

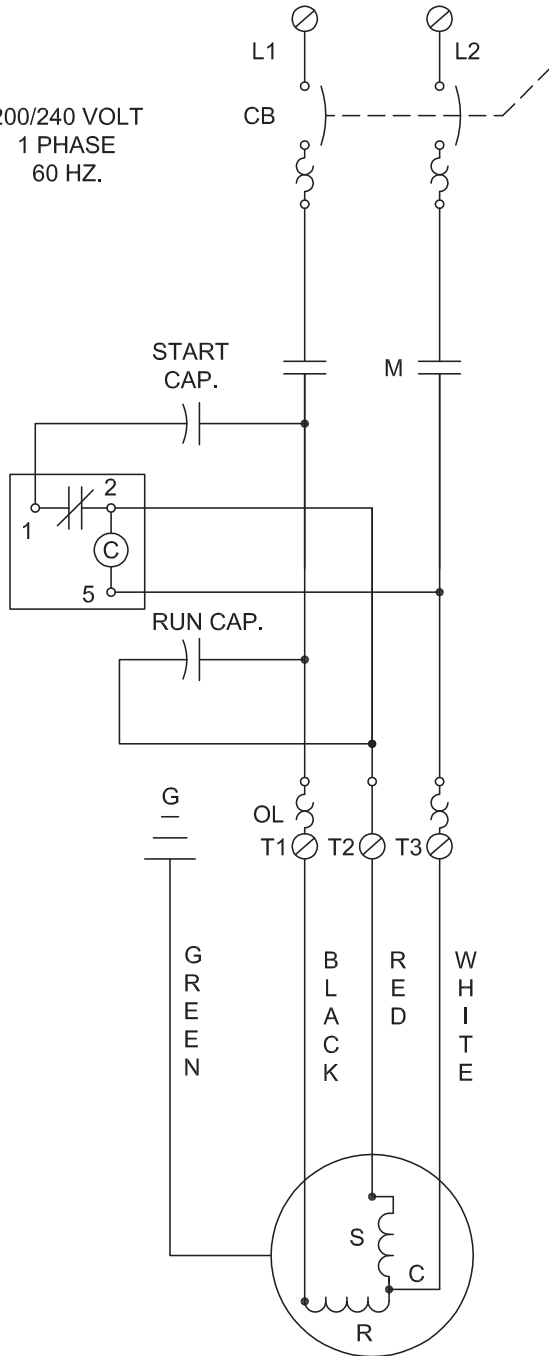

200-240/480 VOLT  
3 PHASE  
60 HZ.

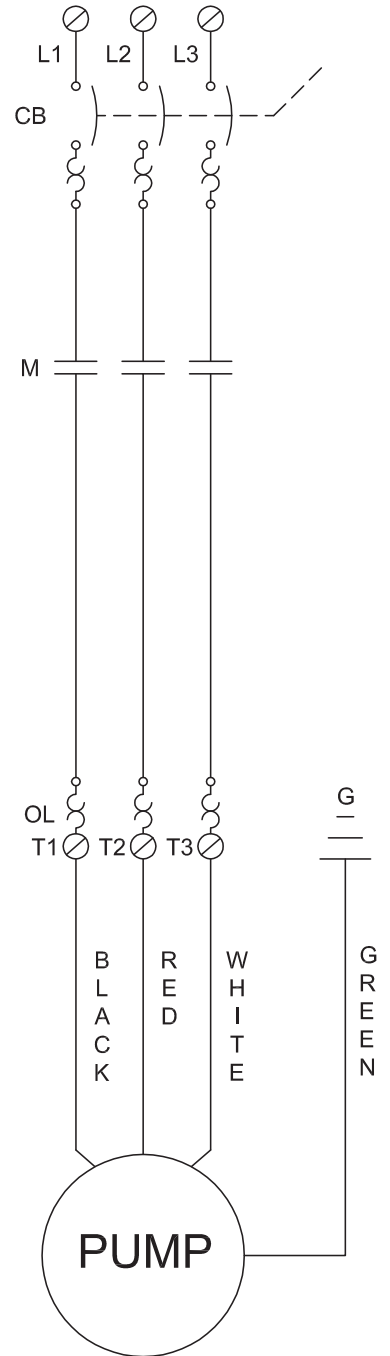

## TROUBLE SHOOTING

**CAUTION !** Always disconnect the pump from the electrical power source before handling.  
If the system fails to operate properly, carefully read instructions and perform maintenance recommendations.  
If operating problems persist, the following chart may be of assistance in identifying and correcting them:

**MATCH "CAUSE" NUMBER WITH CORRELATING "CORRECTION" NUMBER.**

**NOTE:** Not all problems and corrections will apply to each pump model.

PROBLEM	CAUSE	CORRECTION
Pump will not run	<ol style="list-style-type: none"> <li>1. Poor electrical connection, blown fuse, tripped breaker or other interruption of power, improper power supply.</li> <li>2. Motor or switch inoperative (to isolate cause, go to manual operation of pump).                             <ol style="list-style-type: none"> <li>2a. Float movement restricted.</li> <li>2b. Switch will not activate pump or is defective.</li> </ol> </li> <li>3. Insufficient liquid level.</li> </ol>	<ol style="list-style-type: none"> <li>1. Check all electrical connections for security. Have electrician measure current in motor leads, if current is within <math>\pm 20\%</math> of locked rotor Amps, impeller is probably locked. If current is 0, overload may be tripped. Remove power, allow pump to cool, then recheck current.</li> <li>2a. Reposition pump or clean basin as required to provide adequate clearance for float.</li> </ol>
Pump will not turn off	<ol style="list-style-type: none"> <li>2a. Float movement restricted.</li> <li>2b. Switch will not activate pump or is defective.</li> <li>4. Excessive inflow or pump not properly sized for application.</li> <li>9. Pump may be airlocked.</li> <li>14. H-O-A switch on panel is in "HAND" position</li> </ol>	<ol style="list-style-type: none"> <li>2b. Disconnect level control. Set ohmmeter for a low range, such as 100 ohms full scale and connect to level control leads. Actuate level control manually and check to see that ohmmeter shows zero ohms for closed switch and full scale for open switch. (Float Switch).</li> <li>3. Make sure liquid level is at least equal to suggested turn-on point.</li> </ol>
Pump hums but does not run	<ol style="list-style-type: none"> <li>1. Incorrect voltage</li> <li>8. Cutter jammed or loose on shaft, worn or damaged, inlet plugged.</li> </ol>	<ol style="list-style-type: none"> <li>4. Recheck all sizing calculations to determine proper pump size.</li> </ol>
Pump delivers insufficient capacity	<ol style="list-style-type: none"> <li>1. Incorrect voltage.</li> <li>4. Excessive inflow or pump not properly sized for application.</li> <li>5. Discharge restricted.</li> <li>6. Check valve stuck closed or installed backwards.</li> <li>7. Shut-off valve closed.</li> <li>8. Cutter jammed or loose on shaft, worn or damaged, inlet plugged.</li> <li>9. Pump may be airlocked.</li> <li>10. Pump stator damaged/torn.</li> </ol>	<ol style="list-style-type: none"> <li>5. Check discharge line for restrictions, including ice if line passes through or into cold areas.</li> <li>6. Remove and examine check valve for proper installation and freedom of operation.</li> <li>7. Open valve.</li> <li>8. Check cutter for freedom of operation, security and condition. Clean cutter and inlet of any obstruction.</li> <li>9. Loosen union slightly to allow trapped air to escape. Verify that turn-off level of switch is set so that the suction is always flooded. Clean vent hole.</li> </ol>
Pump cycles too frequently or runs periodically when fixtures are not in use	<ol style="list-style-type: none"> <li>6. Check valve stuck closed or installed backwards.</li> <li>11. Fixtures are leaking.</li> <li>15. Ground water entering basin.</li> </ol>	<ol style="list-style-type: none"> <li>10. Remove &amp; examine for damage. Replace pump stator if required.</li> <li>11. Repair fixtures as required to eliminate leakage.</li> </ol>
Pump shuts off and turns on independent of switch, (trips thermal overload protector). <b>CAUTION!</b> Pump may start unexpectedly. Disconnect power supply.	<ol style="list-style-type: none"> <li>1. Incorrect voltage.</li> <li>4. Excessive inflow or pump not properly sized for application.</li> <li>8. Cutter jammed, loose on shaft, worn or damaged, inlet plugged.</li> <li>12. Excessive water temperature.</li> </ol>	<ol style="list-style-type: none"> <li>12. Check pump temperature limits &amp; fluid temperature.</li> <li>13. Replace portion of discharge pipe with flexible connector.</li> <li>14. Turn to automatic position.</li> </ol>
Pump operates noisily or vibrates excessively	<ol style="list-style-type: none"> <li>4. Operating at too high a pressure.</li> <li>5. Discharge restricted.</li> <li>8. Cutter broken.</li> <li>13. Piping attachments to building structure too rigid or too loose.</li> </ol>	<ol style="list-style-type: none"> <li>15. Check for leaks around basin inlet and outlets.</li> </ol>

MODEL:PART NO.	
SGV3072L	111608
SGV3062L	111612
SGV3032L	111609
SGV3042L	111610
SGV3052L	111611

MODEL:PART NO.	
SGV5002L	115657
SGV5022L	115658
SGV5062L	111619
SGV5032L	111616
SGV5042L	111617
SGV5052L	111618

MODEL:PART NO.	
SGV7532L	111613
SGV7542L	111614
SGV7552L	111615

**SGV5002L & SGV5022L ONLY**

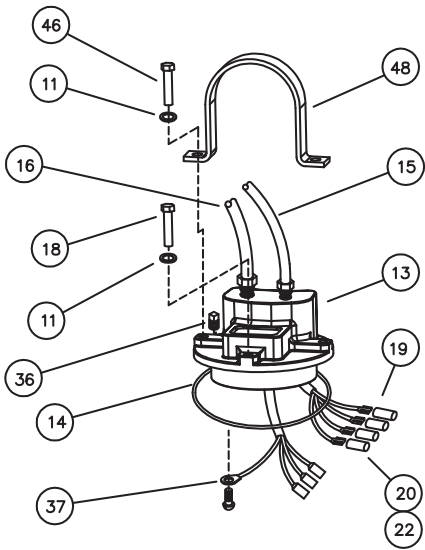

**ALL OTHER MODELS**

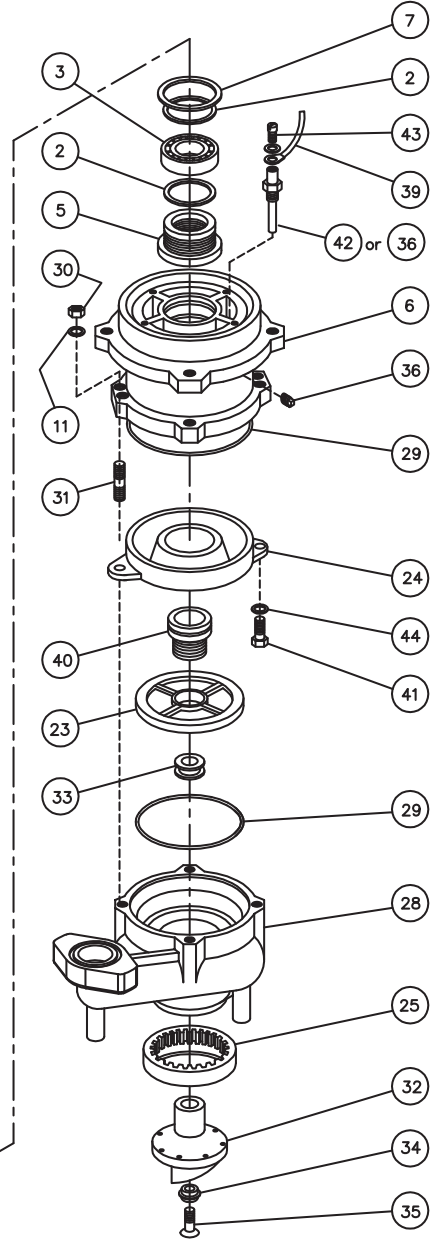
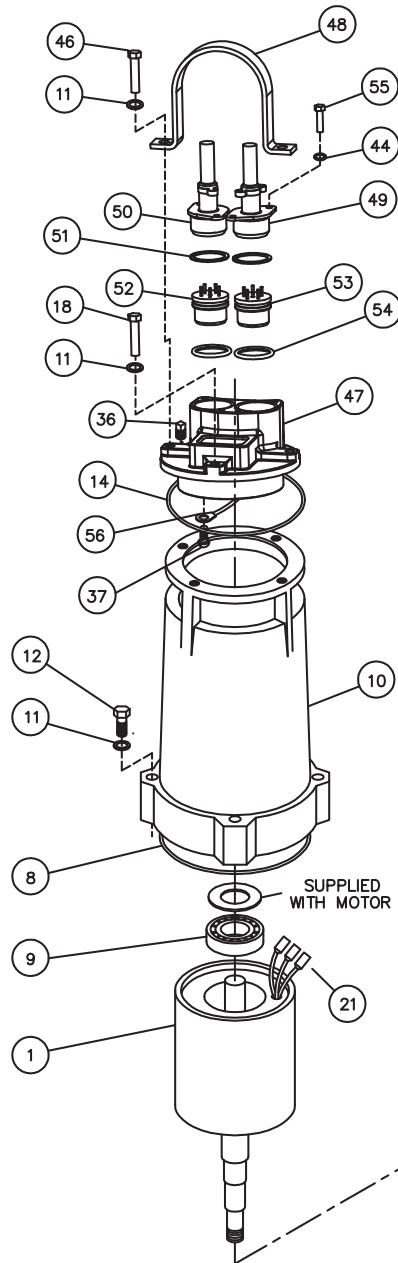

## PARTS KITS

**Seal Repair Kit, All Except 5Hp, 1Ph .... P/N: 085223**  
**Seal Repair Kit, For 5Hp, 1Ph Only..... P/N: 118042**  
**Overhaul Kit, All Except 5Hp, 1Ph..... P/N: 115771**  
**Overhaul Kit, For 5Hp, 1Ph Only..... P/N: 115772**  
**Cutter Kit ..... P/N: 085225**

Item #s 5,8,14,16D,29,34,35,40  
 Item #s 5,8,14,15D,16D,29,34,35,40  
 Item #s 2,3,5,7,8,9,14,16d,19,22,29,34,35,40  
 Item #s 2,3,5,7,8,9,14,15d,16d,19,22,29,34,35,40  
 Item #s 12,25,27,32,33,34,35

## PARTS LIST

ITEM	QTY	PART NO.	DESCRIPTION
1	1	116430	MOTOR: 3HP, 200-240V, 1Ph
		116431	3HP, 200V, 3Ph
		116432	3HP, 240/480V, 3Ph
		116433	3HP, 600V, 3Ph
		115358	5HP, 200-240V, 1Ph
		116435	5HP, 200V, 3Ph
		116436	5HP, 240/480V, 3Ph
		116437	5HP, 600V, 3Ph
		116438	7.5HP, 240/480V, 3Ph
		116439	7.5HP, 600V, 3Ph
2	2	019851	Retaining Ring
3	1	061031	Ball Bearing
5	1	070713	Seal, Inner, C\C\B (STD)
6	1	087118A	Intermediate Coupling
7	1	070708	Retaining Ring
8	1	070711	Square Ring
9	1	017414	Ball Bearing
10	1	070715	Motor Housing
11	12	027115	Lockwasher. 7/16" SS
12	6	053525	Screw 7/16-14 x 2.25" SS
<b>See Cord &amp; Plate Assemblies</b>			
23	1	132462	Impeller, Cast Iron 6.46" Dia. (STD), 7.5HP
		132462TB	6.25" Dia. (STD), 5HP
		132462TM	5.00" Dia. (STD), 3HP
24	1	070714	Seal Plate
25	1	070729	Shredding Ring
28	1	072084B	Volute (STD)
29	1	019289	Square Ring
30	4	027116	Hex Nut 7/16-14, SS
31	4	070706	Stud 7/16-14 x 3.25" SS
32	1	070728	Radial Cutter
33	2	070707	Shim (.010)
34	1	070702	Washer, SS
35	1	070703	Screw 3/8-16 x 1.75" SS
36	4	003217	Pipe Plug (2 replaced by Opt. Moist. sensor #42
37	1	2-61-6	Ground Screw

ITEM	QTY.	PART NO.	DESCRIPTION
38	4¾ Qts	029034	Motor Cooling Oil (±)
	1½ Qts	029034	Seal Cavity
39	2	070108	Wire Assy, M/S - 5HP 1Ph Only
		070108A	Wire Assy, Moisture Sensor
40	1	070712	Seal, Outer, C\C\B (STD)
41		1-131-1	Screw 5/16-18 x 1.25" SS
42	2	087115	Moisture Sensor (Opt)
43	2	038156	Machine screw, Moist. (Opt)
44	2	026322	Lockwasher 5/16 SS (Opt)
45	1	070717	Sleeve Bearing (included w/#6)
<b>Cord &amp; Plate Assembly for Models SGV5022L &amp; SGV5002L ONLY</b>			
13	1	112162A	Cover Plate SGV5022L -ONLY
		112162B	SGV5002L - ONLY
14	1	067564	Square Ring
15	1	093284XC	Cord Set, Power, 30Ft (STD)
		093285XC	SGV5002L - Only SGV5022L - Only
15B	1	052259	Gland Nut SGV5002L & SGV5022L
15C	2	110929	Friction Ring SGV5002L & SGV5022L
		110928	Grommet SGV5002L & SGV5022L
16	1	071769XC	Cord Set, Temp, 30Ft. (STD)
		079031XC	Cord Set, Moist & Temp, 30Ft
16B	1	051448	Gland Nut
16C	2	051449	Friction Ring, Temp Friction Ring, Moist & Temp
		051451	Grommet, Temp Grommet, Moist & Temp
16D	1	066871	Grommet, Temp Grommet, Moist & Temp
18	2	1-147-1	Screw 7/16-14 x 1.50" SS
19	4	079318	Terminal Connector, Moist
	2	079318	Terminal Connector, Temp
20	3	016405	Wire Connector, 1 & 3Ph, 480V
21	3	625-00163	Wire Connector, 3 Phase Only
22	3	016406	Connector (All except 240V, 3Ph)
		052290*	7.5HP, 240V, 3Ph
		055844	5 & 3HP, 240V, 3Ph
		030148	5HP, 1Ph
46	2	1-319-1	Screw 7/16-14 x 2" SS
48	1	113316	Lifting Bail
<b>Continued on Next Page</b>			

ITEM	QTY	PART NO.	DESCRIPTION
<b>Cord &amp; Plate Assembly for ALL Other Models</b>			
14	1	067564	Square Ring
18	2	1-147-1	Screw 7/16-14 x 1.50" SS
46	2	1-319-1	Screw 7/16-14 x 2" SS
47	1	112162	Cover Plate
48	1	113316	Lifting Bail
49	1	103741XC 113288XC	Cord Set 14/3 Temp Only Cord Set 18/5 Moist & Temp
50	1	103739XC	Cord Set 10/4 Power
51	2	2-31051-224	O-Ring
52	1	103586	Terminal Block, 4 Pin - Power
53	1	103584 113272	Temp - Terminal Block Moist & Temp - Terminal Block
54	2	105197	Retaining Ring
55	4	1-156-1	Screw 5/16-18 x 1" SS
56	1	105111A 105111	Ground Wire Assy Ground Wire Assy (Opt. Moist. sensor only)

Contact your local Distributor or the Factory for other impeller sizes, seal materials, cord lengths and other optional equipment.  
 (‡) Oil capacity shown is for the smallest HP motor, as HP increases oil capacity decreases.

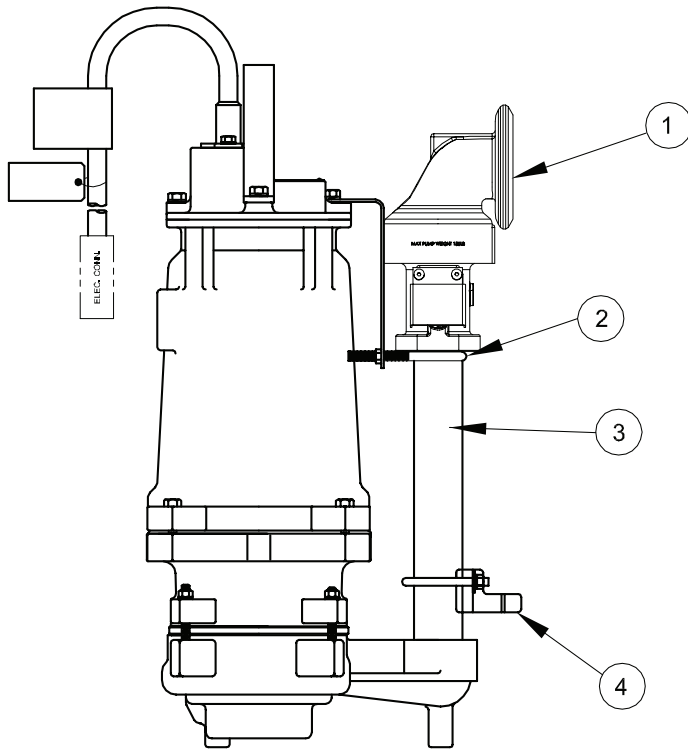

**MOVEABLE ASSEMBLY  
 P/N: 116728\* PARTS LIST  
 For 3, 5, & 7.5HP SGV Grinders,  
 "C" Channel Basin Package**

ITEM	QTY	PART NO	DESCRIPTION
1	1	115254	Check Valve/Upper Moveable
2	1	116726	Upper Pump Support Assy.
3	1	107369	Pipe Nipple 2" x 15" Lg
4	1	107361	Lower Guide Support Assy

(\*) Pump **NOT** included under this part number. The Moveable Assembly will be factory assembled to the pump when a Basin Package system is ordered.

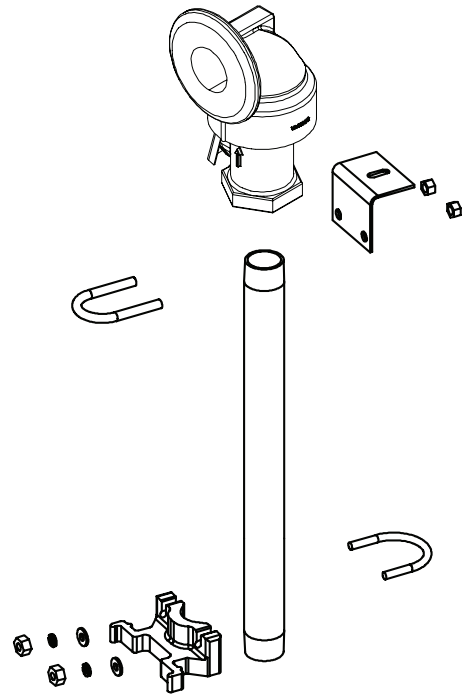

**BARNES®**



**burks®**

**WEINMAN®**

**DEMING®**

**PROSSER®**

## Limited 24 Month Warranty

Crane Pumps & Systems warrants that products of our manufacture will be free of defects in material and workmanship under normal use and service for twenty-four (24) months after manufacture date, when installed and maintained in accordance with our instructions. This warranty gives you specific legal rights, and there may also be other rights which vary from state to state. In the event the product is covered by the Federal Consumer Product Warranties Law (1) the duration of any implied warranties associated with the product by virtue of said law is limited to the same duration as stated herein, (2) this warranty is a LIMITED WARRANTY, and (3) no claims of any nature whatsoever shall be made against us, until the ultimate consumer, his successor, or assigns, notifies us in writing of the defect, and delivers the product and/or defective part(s) freight prepaid to our factory or nearest authorized service station. Some states do not allow limitations on how long an implied warranty lasts, so the above limitation may not apply. **THE SOLE AND EXCLUSIVE REMEDY FOR BREACH OF ANY AND ALL WARRANTIES WITH RESPECT TO ANY PRODUCT SHALL BE TO REPLACE OR REPAIR AT OUR ELECTION, F.O.B. POINT OF MANUFACTURE OR AUTHORIZED REPAIR STATION, SUCH PRODUCTS AND/OR PARTS AS PROVEN DEFECTIVE. THERE SHALL BE NO FURTHER LIABILITY, WHETHER BASED ON WARRANTY, NEGLIGENCE OR OTHERWISE.** Unless expressly stated otherwise, guarantees in the nature of performance specifications furnished in addition to the foregoing material and workmanship warranties on a product manufactured by us, if any, are subject to laboratory tests corrected for field performance. Any additional guarantees, in the nature of performance specifications must be in writing and such writing must be signed by our authorized representative. Due to inaccuracies in field testing if a conflict arises between the results of field testing conducted by or for user, and laboratory tests corrected for field performance, the latter shall control. **RECOMMENDATIONS FOR SPECIAL APPLICATIONS OR THOSE RESULTING FROM SYSTEMS ANALYSES AND EVALUATIONS WE CONDUCT WILL BE BASED ON OUR BEST AVAILABLE EXPERIENCE AND PUBLISHED INDUSTRY INFORMATION. SUCH RECOMMENDATIONS DO NOT CONSTITUTE A WARRANTY OF SATISFACTORY PERFORMANCE AND NO SUCH WARRANTY IS GIVEN.**

This warranty shall not apply when damage is caused by (a) improper installation, (b) improper voltage (c) lightning (d) excessive sand or other abrasive material (e) scale or corrosion build-up due to excessive chemical content. Any modification of the original equipment will also void the warranty. We will not be responsible for loss, damage or labor cost due to interruption of service caused by defective parts. Neither will we accept charges incurred by others without our prior written approval.

This warranty is void if our inspection reveals the product was used in a manner inconsistent with normal industry practice and/or our specific recommendations. The purchaser is responsible for communication of all necessary information regarding the application and use of the product. **UNDER NO CIRCUMSTANCES WILL WE BE RESPONSIBLE FOR ANY OTHER DIRECT OR CONSEQUENTIAL DAMAGES, INCLUDING BUT NOT LIMITED TO TRAVEL EXPENSES, RENTED EQUIPMENT, OUTSIDE CONTRACTOR FEES, UNAUTHORIZED REPAIR SHOP EXPENSES, LOST PROFITS, LOST INCOME, LABOR CHARGES, DELAYS IN PRODUCTION, IDLE PRODUCTION, WHICH DAMAGES ARE CAUSED BY ANY DEFECTS IN MATERIAL AND/OR WORKMANSHIP AND/OR DAMAGE OR DELAYS IN SHIPMENT. THIS WARRANTY IS EXPRESSLY IN LIEU OF ANY OTHER EXPRESS OR IMPLIED WARRANTY, INCLUDING ANY WARRANTY OF MERCHANTABILITY OR FITNESS FOR A PARTICULAR PURPOSE.**

No rights extended under this warranty shall be assigned to any other person, whether by operation of law or otherwise, without our prior written approval.

**CRANE**  
®

**PUMPS & SYSTEMS**

A Crane Co. Company

420 Third Street  
Piqua, Ohio 45356  
(937) 778-8947  
Fax (937) 773-7157  
[www.cranepumps.com](http://www.cranepumps.com)

83 West Drive  
Brampton, Ont. Canada L6T 2J6  
(905) 457-6223  
Fax (905) 457-2650



**IMPORTANT!  
WARRANTY REGISTRATION**

Your product is covered by the enclosed Warranty.  
To complete the Warranty Registration Form go to:

<http://www.cranepumps.com/ProductRegistration/>

If you have a claim under the provision of the warranty, contact your local  
Crane Pumps & Systems, Inc. Distributor.

**RETURNED GOODS**

**RETURN OF MERCHANDISE REQUIRES A "RETURNED GOODS AUTHORIZATION".  
CONTACT YOUR LOCAL CRANE PUMPS & SYSTEMS, INC. DISTRIBUTOR.**



**Products Returned Must Be Cleaned, Sanitized,  
Or Decontaminated As Necessary Prior To Shipment,  
To Insure That Employees Will Not Be Exposed To Health  
Hazards In Handling Said Material. All Applicable Laws  
And Regulations Shall Apply.**



A Crane Co. Company

# PUMPS & SYSTEMS

## START-UP REPORT

### General Information

Pump Owner's Name: \_\_\_\_\_  
 Address: \_\_\_\_\_  
 Location of Installation: \_\_\_\_\_  
 Contact Person: \_\_\_\_\_ Phone: \_\_\_\_\_  
 Purchased From: \_\_\_\_\_

### Nameplate Data

Pump Model #: \_\_\_\_\_ Serial #: \_\_\_\_\_  
 Part #: \_\_\_\_\_ Impeller Diameter: \_\_\_\_\_  
 Voltage: \_\_\_\_\_ Phase: \_\_\_\_\_ Ø Hertz: \_\_\_\_\_ Horsepower: \_\_\_\_\_  
 Full Load Amps: \_\_\_\_\_ Service Factor Amps: \_\_\_\_\_  
 Motor Manufacturer: \_\_\_\_\_

### Controls

Control panel manufacturer: \_\_\_\_\_  
 Model/Part number: \_\_\_\_\_  
 Number of pumps operated by control panel: \_\_\_\_\_  
 Short circuit protection? YES\_\_\_ NO\_\_\_ Type: \_\_\_\_\_  
 Number and size of short circuit device(s): \_\_\_\_\_ Amp rating: \_\_\_\_\_  
 Overload Type: \_\_\_\_\_ Size: \_\_\_\_\_ Amp rating: \_\_\_\_\_  
 Do protection devices comply with pump and motor Amp rating? YES\_\_\_ NO\_\_\_  
 Are all electrical and panel entry connections tight? YES\_\_\_ NO\_\_\_  
 Is the interior of the panel dry? YES\_\_\_ NO\_\_\_  
 Liquid level Control Brand and Model: \_\_\_\_\_

### Pre-Startup

#### All Pumps

Type of equipment: NEW\_\_\_ REBUILT\_\_\_ USED\_\_\_  
 Condition of equipment at Start-Up: DRY\_\_\_ WET\_\_\_ MUDDY\_\_\_  
 Was Equipment Stored? YES\_\_\_ NO\_\_\_ Length of Storage: \_\_\_\_\_  
 Liquid being pumped: \_\_\_\_\_ Liquid Temperature: \_\_\_\_\_  
 Supply Voltage/Phase/Frequency matches nameplate? YES\_\_\_ NO\_\_\_  
 Shaft turns freely? YES\_\_\_ NO\_\_\_  
 Direction of rotation verified for 3Ø motors? YES\_\_\_ NO\_\_\_  
 Debris in piping or wet well? YES\_\_\_ NO\_\_\_  
 Debris removed in your presence? YES\_\_\_ NO\_\_\_  
 Pump case/wet well filled with liquid before startup? YES\_\_\_ NO\_\_\_  
 Is piping properly supported? YES\_\_\_ NO\_\_\_

#### Non-Submersible Pumps

Is base plate properly installed / grouted? YES\_\_\_ NO\_\_\_ N/A\_\_\_  
 Coupling Alignment Verified per I&O Manual? YES\_\_\_ NO\_\_\_ N/A\_\_\_  
 Grease Cup/Oil Reservoir Level checked? YES\_\_\_ NO\_\_\_ N/A\_\_\_

**Submersible Pumps**

Resistance of cable and pump motor (measured at pump control):

Red-Black: \_\_\_\_\_ Ohms(Ω) Red-White: \_\_\_\_\_ Ohms(Ω) White-Black: \_\_\_\_\_ Ohms(Ω)

Resistance of Ground Circuit between Control Panel and outside of pump: \_\_\_\_\_ Ohms(Ω)

MEG Ohms check of insulation:

Red to Ground: \_\_\_\_\_ White to Ground: \_\_\_\_\_ Black to Ground: \_\_\_\_\_

**Operational Checks**

Is there noise or vibration present? YES\_\_\_ NO\_\_\_ Source of noise/vibration: \_\_\_\_\_

Does check valve operate properly? YES\_\_\_ NO\_\_\_ N/A\_\_\_

Is system free of leaks? YES\_\_\_ NO\_\_\_ Leaks at: \_\_\_\_\_

Does system appear to operate at design flow rate? YES\_\_\_ NO\_\_\_

Nominal Voltage: \_\_\_\_\_ Phase: 1Ø 3Ø (select one)

Voltage Reading at panel connection, Pump OFF: L1, L2 \_\_\_\_\_ L2, L3 \_\_\_\_\_ L1, L3 \_\_\_\_\_

Voltage Reading at panel connection, Pump ON: L1, L2 \_\_\_\_\_ L2, L3 \_\_\_\_\_ L1, L3 \_\_\_\_\_

Amperage Draw, Pump ON: L1 \_\_\_\_\_ L2 \_\_\_\_\_ L3 \_\_\_\_\_

**Submersible Pumps**

Are BAF and guide rails level / plumb? YES\_\_\_ NO\_\_\_

Is pump seated on discharge properly? YES\_\_\_ NO\_\_\_

Are level controls installed away from turbulence? YES\_\_\_ NO\_\_\_

Is level control operating properly? YES\_\_\_ NO\_\_\_

Is pump fully submerged during operation? YES\_\_\_ NO\_\_\_

**Follow up/Corrective Action Required**

YES\_\_\_ NO\_\_\_

**Additional Comments:**

\_\_\_\_\_  
\_\_\_\_\_  
\_\_\_\_\_  
\_\_\_\_\_  
\_\_\_\_\_  
\_\_\_\_\_  
\_\_\_\_\_

Startup performed by: \_\_\_\_\_ Date: \_\_\_\_\_

**Present at Start-Up**

( ) Engineer: \_\_\_\_\_ ( ) Operator: \_\_\_\_\_

( ) Contactor: \_\_\_\_\_ ( ) Other: \_\_\_\_\_

**All parties should retain a copy of this report for future trouble shooting/reference**



**PUMPS & SYSTEMS**

A Crane Co. Company

420 Third Street  
Piqua, Ohio 45356  
(937) 778-8947  
Fax (937) 773-7157  
www.cranepumps.com

83 West Drive  
Brampton, Ont. Canada L6T 2J6  
(905) 457-6223  
Fax (905) 457-2650

