

BARNES®

INSTALLATION MANUAL Submersible Effluent & Sewage Ejector

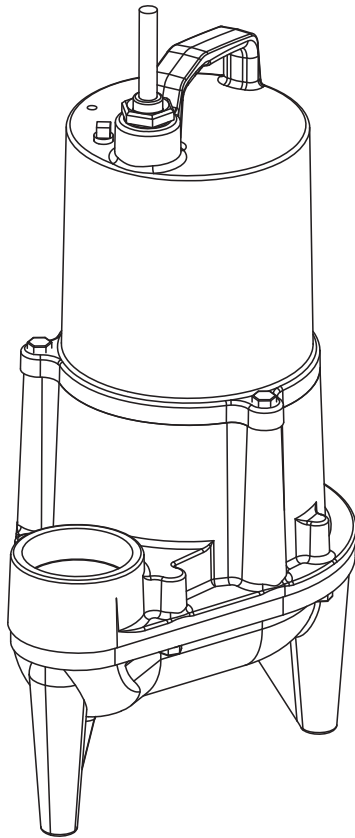

**Series: SEV412
EHV412**
1/2 HP, 3450 RPM, 60 Hz.

IMPORTANT!

*Read all instructions in this manual before operating pump.
As a result of Crane Pumps & Systems, Inc., constant product improvement program,
product changes may occur. As such Crane Pumps & Systems reserves the right to
change product without prior written notification.*

CRANE

A Crane Co. Company

PUMPS & SYSTEMS

420 Third Street
Piqua, Ohio 45356
Phone: (937) 778-8947
Fax: (937) 773-7157
www.cranepumps.com

83 West Drive, Brampton
Ontario, Canada L6T 2J6
Phone: (905) 457-6223
Fax: (905) 457-2650



Form No. 102075-Rev. AA

SAFETY FIRST!

Please Read This Before Installing Or Operating Pump. This information is provided for **SAFETY** and to **PREVENT EQUIPMENT PROBLEMS**. To help recognize this information, observe the following symbols:



IMPORTANT! Warns about hazards that can result in personal injury or indicates factors concerned with assembly, installation, operation, or maintenance which could result in damage to the machine or equipment if ignored.

CAUTION! Warns about hazards that **can or will cause minor** personal injury or property damage if ignored. Used with symbols below.

WARNING! Warns about hazards that can or will cause serious personal injury, death, or major property damage if ignored. Used with symbols below.



Hazardous fluids can cause fire or explosions, burns or death could result.



Extremely hot - Severe burns can occur on contact.



Biohazard can cause serious personal injury.



Hazardous fluids can cause hazardous pressure, eruptions or explosions could cause personal injury or property damage.



Rotating machinery Amputation or severe laceration can result.



Hazardous voltage can shock, burn or cause death.

Only qualified personnel should install, operate and repair pump. Any wiring of pumps should be performed by a qualified electrician.

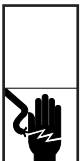

WARNING ! To reduce risk of electrical shock, pumps and control panels must be properly grounded in accordance with the National Electric Code (NEC) or the Canadian Electrical Code (CEC) and all applicable state, province, local codes and ordinances. Improper grounding voids warranty.



WARNING! To reduce risk of electrical shock, always disconnect the pump from the power source before handling or servicing. Lock out power and tag.



WARNING! Operation against a closed discharge valve will cause premature bearing and seal failure on any pump, and on end suction and self priming pump the heat build may cause the generation of steam with resulting dangerous pressures. It is recommended that a high case temperature switch or pressure relief valve be installed on the pump body.



CAUTION ! Never operate a pump with a plug-in type power cord without a ground fault circuit interrupter.



CAUTION ! Pumps build up heat and pressure during operation-allow time for pumps to cool before handling or servicing.



WARNING ! Do not pump hazardous materials (flammable, caustic, etc.) unless the pump is specifically designed and designated to handle them.



CAUTION ! Do not block or restrict discharge hose, as discharge hose may whip under pressure.



WARNING ! Do not wear loose clothing that may become entangled in moving parts.



WARNING ! Keep clear of suction and discharge openings. **DO NOT** insert fingers in pump with power connected.



Always wear eye protection when working on pumps.

Make sure lifting handles are securely fastened each time before lifting. **DO NOT** operate pump without safety devices in place. Always replace safety devices that have been removed during service or repair. Secure the pump in its operating position so it can not tip over, fall or slide.



DO NOT exceed manufacturers recommendation for maximum performance, as this could cause the motor to overheat.



DO NOT remove cord and strain relief. **DO NOT** connect conduit to pump.



WARNING ! Cable should be protected at all times to avoid punctures, cut, bruises and abrasions. Inspect frequently. Never handle connected power cords with wet hands.



WARNING ! To reduce risk of electrical shock, all wiring and junction connections should be made per the NEC or CEC and applicable state or province and local codes. Requirements may vary depending on usage and location.



WARNING! Submersible Pumps are not approved for use in swimming pools, recreational water installations decorative fountains or any installation where human contact with the pumped fluid is common.



WARNING! Products returned must be cleaned, sanitized, or decontaminated as necessary prior to shipment, to insure that employees will not be exposed to health hazards in handling said material. All Applicable Laws And Regulations Shall Apply.



Bronze/brass and bronze/brass fitted pumps may contain lead levels higher than considered safe for potable water systems. Lead is known to cause cancer and birth defects or other reproductive harm. Various government agencies have determined that leaded copper alloys should not be used in potable water applications. For non-leaded copper alloy materials of construction, please contact factory.



Crane Pumps & Systems, Inc. is not responsible for losses, injury, or death resulting from a failure to observe these safety precautions, misuse or abuse of pumps or equipment.

Other brand and product names are trademarks or registered trademarks of their respective holders.

® Barnes is a registered trademark of Crane Pumps & Systems, Inc.

1998, 2000, 2001, 2002, 2003, 8/05, 2/06, 9/06

PUMP SPECIFICATIONS - SEV412 SERIES:

DISCHARGE 2" NPT, Female, Vertical
LIQUID TEMPERATURE 77°F (25°C) Continuous
MOTOR HOUSING Cast Iron
PUMP BODY Cast Iron
IMPELLER:

Design Multi-vane, vortex
Material Cast Iron

SHAFT 416 Stainless Steel

O-RINGS Buna-N

HARDWARE 300 Series Stainless Steel

PAINT Air dry enamel

SEAL *Design* Single Mechanical, Oil Filled reservoir
Material Carbon/Ceramic/Buna-N

Hardware - 300 series stainless steel

CORD ENTRY 20 Ft. (6m) Quick disconnect cord with plug, pressure grommet for sealing and strain relief.

UPPER BEARING:

Design Single Row, Ball, Oil Lubricated
Load Radial

LOWER BEARING:

Design Single Row, Ball, Oil Lubricated
Load Radial & Thrust

MOTOR: *Design* Oil Filled
Insulation Class B

SINGLE PHASE Permanent Split Capacitor (PSC)
 Includes Thermal Overload Protection in motor

LEVEL CONTROLS:

SEV412 None

SEV412A Wide Angle, PVC, Mechanical,
 20 Ft. (6m) Cord w/Piggy-back plug
 N/O, Pipe Mounted

SEV412AT Wide Angle, PVC, Mechanical,
 20 Ft. (6m) Cord w/Piggy-back plug
 N/O, Pump Mounted

SEV412VF Vertical Float, PVC, Snap Action,
 20 Ft. (6m) Cord w/Piggy-back plug
 OFF Point only is Adjustable

SEV412DT Diaphragm Switch, Pressure Operated,
 Snap Action, Normally Open, 20 Ft.
 (6m) Cord

OPTIONAL EQUIPMENT Seal Material, Additional Cord

SEV412A
SEV412 (Less Float)
SEV412AT (Float Attached to Pump)

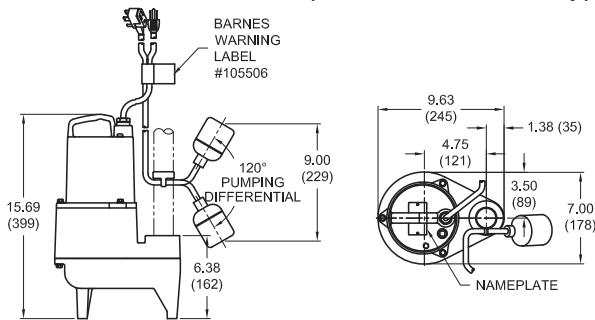

SEV412DT

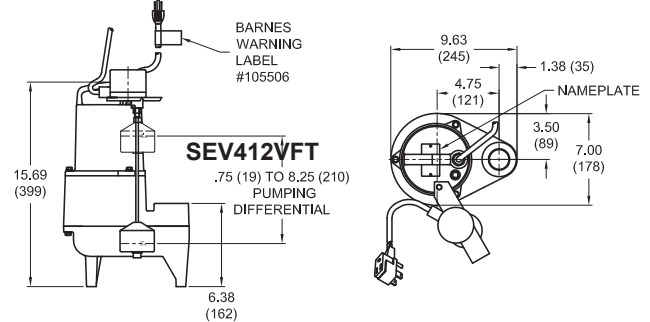

SEV412VF

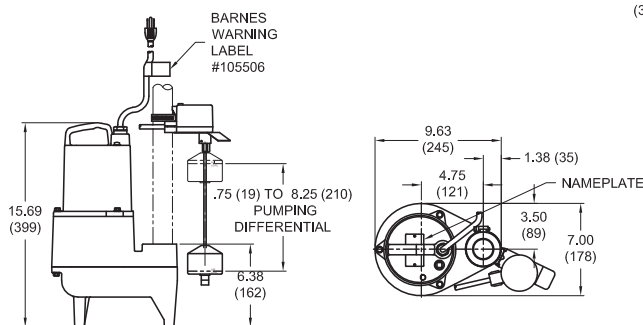

IMPORTANT !

- 1.) PUMP MAY BE OPERATED "DRY" FOR EXTENDED PERIODS WITHOUT DAMAGE TO MOTOR AND/OR SEALS.
- 2.) THIS PUMP IS APPROPRIATE FOR THOSE APPLICATIONS SPECIFIED AS CLASS I DIVISION II HAZARDOUS LOCATIONS.
- 3.) THIS PUMP IS NOT APPROPRIATE FOR THOSE APPLICATIONS SPECIFIED AS CLASS I DIVISION I HAZARDOUS LOCATIONS.
- 4.) INSTALLATIONS SUCH AS DECORATIVE FOUNTAINS OR WATER FEATURES PROVIDED FOR VISUAL ENJOYMENT MUST BE INSTALLED IN ACCORDANCE WITH THE NATIONAL ELECTRIC CODE ANSI/NFPA 70 AND/OR THE AUTHORITY HAVING JURISDICTION. THIS PUMP IS NOT INTENDED FOR USE IN SWIMMING POOLS, RECREATIONAL WATER PARKS, OR INSTALLATIONS IN WHICH HUMAN CONTACT WITH PUMPED MEDIA IS A COMMON OCCURRENCE.

inches
(mm)

PUMP SPECIFICATIONS - EHV412 SERIES:

DISCHARGE 2" NPT, Female, Vertical
LIQUID TEMPERATURE 77°F (25°C) Continuous
MOTOR HOUSING Cast Iron
PUMP BODY Cast Iron
IMPELLER:
 Design Multi-Vane, Vortex
 Material Cast Iron
SHAFT 420 Stainless Steel
O-RINGS Buna-N
HARDWARE 300 Series Stainless Steel
PAINT Air dry enamel
SEAL *Design* Single Mechanical, Oil Filled reservoir
 Material Carbon/Ceramic/Buna-N
 Hardware - 300 series stainless steel
CORD ENTRY 20 Ft. (6m) Quick disconnect cord
 with plug, pressure grommet for
 sealing and strain relief.
UPPER BEARING:
 Design Single Row, Ball, Oil Lubricated
 Load Radial

LOWER BEARING:
 Design Single Row, Ball, Oil Lubricated
 Load Radial & Thrust
MOTOR: *Design* Oil Filled
 Insulation Class B
SINGLE PHASE Permanent Split Capacitor (PSC)
 Includes Thermal Overload
 Protection in motor
LEVEL CONTROLS:
 EHV412 None
 EHV412A Wide Angle, PVC, Mechanical,
 20 Ft. (6m) Cord w/Piggy-back plug
 N/O, Pipe Mounted
 EHV412AT Wide Angle, PVC, Mechanical,
 20 Ft. (6m) Cord w/Piggy-back plug
 N/O, Pump Mounted
 EHV412VF Vertical Float, PVC, Snap Action,
 20 Ft. (6m) Cord w/Piggy-back plug
 OFF Point only is Adjustable
OPTIONAL EQUIPMENT Seal Material, Additional Cord

EHV412A
EHV412 (Less Float)
EHV412AT (Float Attached to Pump)

EHV412VF

inches
 (mm)

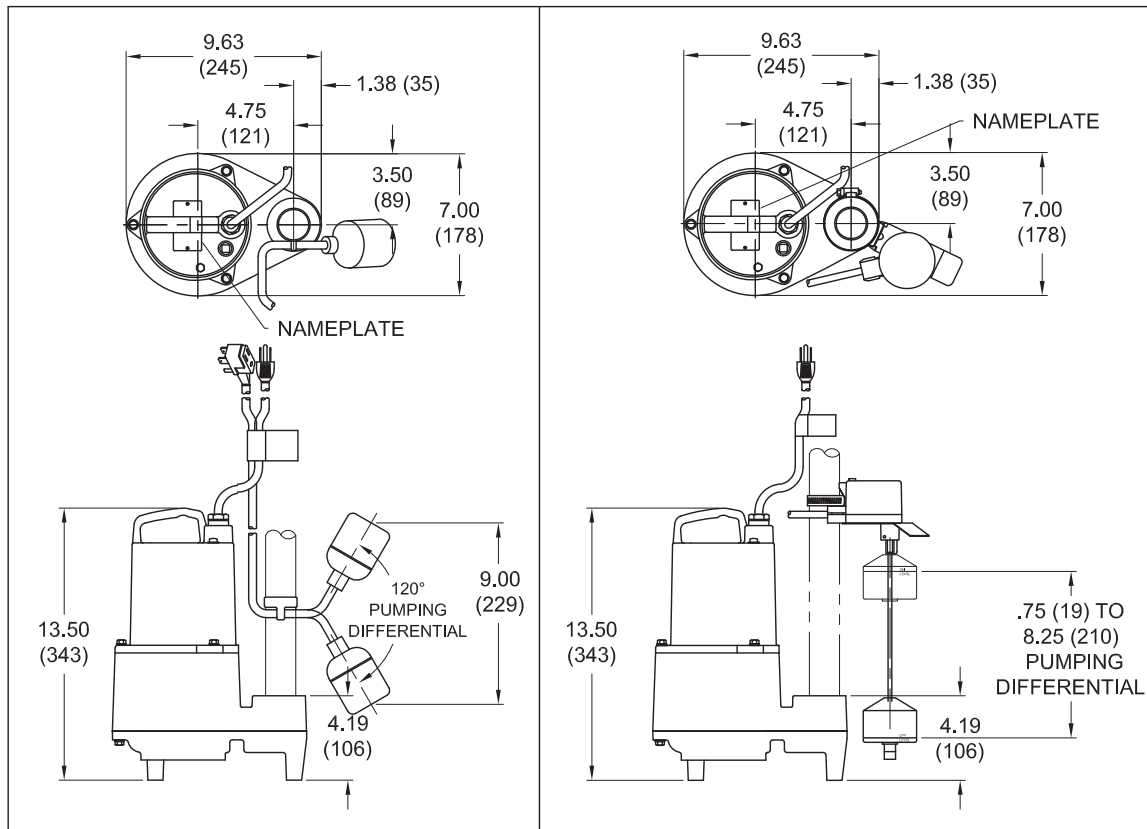

IMPORTANT !

- 1.) PUMP MAY BE OPERATED "DRY" FOR EXTENDED PERIODS WITHOUT DAMAGE TO MOTOR AND/OR SEALS.
- 2.) THIS PUMP IS APPROPRIATE FOR THOSE APPLICATIONS SPECIFIED AS CLASS I DIVISION II HAZARDOUS LOCATIONS.
- 3.) THIS PUMP IS NOT APPROPRIATE FOR THOSE APPLICATIONS SPECIFIED AS CLASS I DIVISION I HAZARDOUS LOCATIONS.
- 4.) INSTALLATIONS SUCH AS DECORATIVE FOUNTAINS OR WATER FEATURES PROVIDED FOR VISUAL ENJOYMENT MUST BE INSTALLED IN ACCORDANCE WITH THE NATIONAL ELECTRIC CODE ANSI/NFPA 70 AND/OR THE AUTHORITY HAVING JURISDICTION. THIS PUMP IS NOT INTENDED FOR USE IN SWIMMING POOLS, RECREATIONAL WATER PARKS, OR INSTALLATIONS IN WHICH HUMAN CONTACT WITH PUMPED MEDIA IS A COMMON OCCURRENCE.

SECTION B: GENERAL INFORMATION

B-1) To The Purchaser:

Congratulations! You are the owner of one of the finest pumps on the market today. Barnes® Pumps are products engineered and manufactured of high quality components. Over one hundred years of pump building experience along with a continuing quality assurance program combine to produce a pump which will stand up to the toughest applications.

Check local codes and requirements before installation. Servicing should be performed by knowledgeable pump service contractors or authorized service stations.

The pump is packaged ready for installation and no connections or adjustments are necessary except for attaching discharge piping and plugging in service cord.

B-2) Receiving:

Upon receiving the pump, it should be inspected for damage or shortages. If damage has occurred, file a claim immediately with the company that delivered the pump. If the manual is removed from the crating, do not lose or misplace.

B-3) Storage:

Short Term- Barnes Pumps are manufactured for efficient performance following long inoperative periods in storage. For best results, pumps can be retained in storage, as factory assembled, in a dry atmosphere with constant temperatures for up to six (6) months.

Long Term- Any length of time exceeding six (6) months, but not more than twenty four (24) months. The units should be stored in a temperature controlled area, a roofed over walled enclosure that provides protection from the elements (rain, snow, wind blown dust, etc.), and whose temperature can be maintained between +40 deg. F and +120 deg. F. Pump should be stored in its original shipping container and before initial start up, rotate impeller by hand to assure seal and impeller rotate freely.

B-4) Service Centers:

For the location of the nearest Barnes Service Center, check your Barnes representative or Crane Pumps & Systems, Inc., Service Department in Piqua, Ohio, telephone (937) 778-8947 or Crane Pumps & Systems Canada, Inc., Bramton, Ontario, (905) 457-6223.

SECTION C: INSTALLATION

C-1) Location:

These pumping units are self-contained and are recommended for use in a sump or basin. The sump or basin shall be vented in accordance with local plumbing codes. This pump is designed to pump effluent or wastewater, nonexplosive and noncorrosive liquids and shall **NOT** be installed in locations classified as hazardous in accordance with the National Electrical Code (NEC),

ANSI/NFPA 70 or the Canadian Electrical Code. Never install the pump in a trench, ditch, or hole with a dirt bottom; the legs will sink into the dirt and the suction will become plugged.

C-1.1) Submergence:

The pump should always be operated in the submerged condition. The minimum sump liquid level should never be less than A Dimension, A = 6.50 inches on SEV Series and A=4.50 inches on EHV Series above the pump bottom. The recommended level should not drop below the top of the motor housing (see Fig. 1).

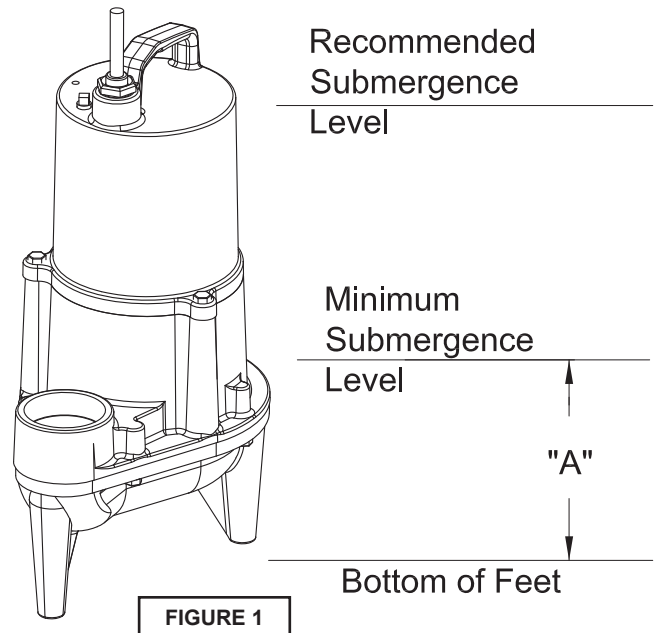

FIGURE 1

C-2) Discharge:

Discharge piping should be as short as possible. Both a check valve and a shut-off valve are recommended for each pump being used. The check valve is used to prevent backflow into the sump. Excessive backflow can cause flooding and/or damage to the pump. The shut-off valve is used to stop system flow during pump or check valve servicing.

C-3) Liquid Level Controls

Figure 2 shows a typical installation for any submersible pump using a level control mounted to the discharge piping with a piggy-back plug.

General Comments:

- 1) Never work in the sump with the power on.
- 2) Level controls are factory set for a pumping differential of 9 inches. If that is the cycle desired, simply circle the discharge pipe with the pipe mounting strap, feed the end through the worm drive, and tighten with a screwdriver. Be certain that the level control cannot hang up or foul in its swing. Also, make certain the pump impeller is still submerged when the level control is in the "OFF" mode.

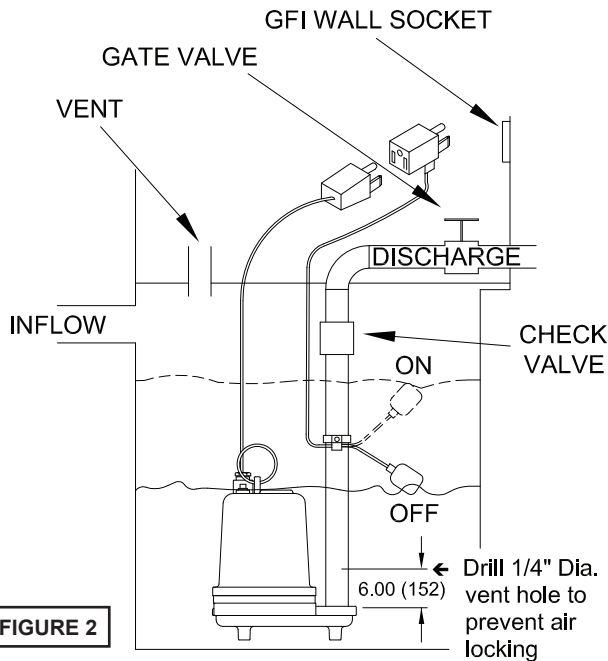

FIGURE 2

- 3) If a higher pump differential is needed, grip the cord near the neck of the float, then using the other hand, exert a steady force on the lower edge of the cable clamp. The cable clamp should slide up to the new pivot point. Attach the level control to the discharge hose in the manner described above.
- 4) Plug the level control plug into the GFI receptacle, then plug the pump into the piggyback plug. One cycle of operation should be observed, so that any potential problems can be corrected.
- 5) It is recommended that the float should be set to insure that the sump well liquid level never drops below the top of the motor housing or a minimum level of 4.50 inches on EHV Series and 6.50 inches on SEV Series above the pump bottom.

6.) Figure 3 shows a typical connection for pumps with the wide angle float and piggy-back plug, for manual and automatic operations.

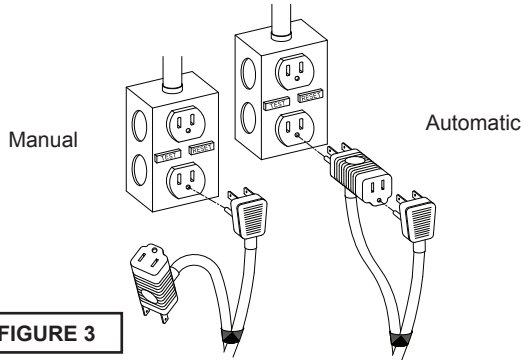

FIGURE 3

Automatic - Plug float cord into GFI outlet, then plug pump cord into float cord.

Manual - Plug pump cord directly into GFI outlet.

C-4) Electrical Connections:

C-4.1) Power Cable:

The cord assembly mounted to the pump must not be modified in any way except for shortening to a specific application. Any splice between the pump and the control panel must be made in accordance with local electric codes. It is recommended that a junction box, if used, be mounted outside the sump or be of at least NEMA 4 (EEMAC-4) construction if located within the wet well. Do not use the power cable to lift pump.

WARNING! - The white wire is not a neutral or ground lead, but a power carrying conductor.

MODEL NO	HP	VOLT/PH	Hz	RPM (Nom)	NEMA START CODE	FULL LOAD AMPS	LOCKED ROTOR AMPS	CORD SIZE	CORD TYPE	WINDING RESISTANCE MAIN - START
SEV412	0.5	115/1	60	3450	H	10.50	18.6	14/3	SJTOW	3.5 - 43
SEV412A	0.5	115/1	60	3450	H	10.50	18.6	14/3	SJTOW	3.5 - 43
SEV412VF	0.5	115/1	60	3450	H	10.50	18.6	14/3	SJTOW	3.5 - 43
SEV412AT	0.5	115/1	60	3450	H	10.50	18.6	14/3	SJTOW	3.5 - 43
SEV412VFT	0.5	115/1	60	3450	H	10.50	18.6	14/3	SJTOW	3.5 - 43
SEV412DT	0.5	115/1	60	3450	H	10.50	18.6	14/3	SJTOW	3.5 - 43
EHV412	0.5	115/1	60	3450	H	6.4	19.6	14/3	SJTOW	3.5 - 43
EHV412A	0.5	115/1	60	3450	H	6.4	19.6	14/3	SJTOW	3.5 - 43
EHV412VF	0.5	115/1	60	3450	H	6.4	19.6	14/3	SJTOW	3.5 - 43
EHV412AT	0.5	115/1	60	3450	H	6.4	19.6	14/3	SJTOW	3.5 - 43
EHV412VFT	0.5	115/1	60	3450	H	6.4	19.6	14/3	SJTOW	3.5 - 43

Winding Resistance ± 5%.
Pump rated for operation at ± 10% voltage at motor.

C-4.2) Overload Protection:

Single Phase - The type of in-winding overload protector used is referred to as an inherent overheating protector and operates on the combined effect of temperature and current. This means that the overload protector will trip out and shut the pump off if the windings become too hot, or the load current passing through them becomes too high. It will then automatically reset and start the pump up after the motor cools to a safe temperature. In the event of an overload, the source of this condition should be determined and rectified immediately. **DO NOT LET THE PUMP CYCLE OR RUN IF AN OVERLOAD CONDITION OCCURS !**

If current through the temperature sensor exceeds the values listed, an intermediate control circuit relay must be used to reduce the current or the sensor will not work properly.

TEMPERATURE SENSOR ELECTRICAL RATINGS		
Volts	Continuous Amperes	Inrush Amperes
110-120	3.00	30.0

C-4.3) Wire Size:

Consult a qualified electrician for proper wire size. See table for electrical information.

SECTION D: SERVICE AND REPAIR

NOTE: All item numbers () refer to Figure 8.

D-1) Lubrication:

Anytime the pump is removed from operation, the cooling oil in the motor housing must be checked visually for oil level and contamination.

D-1.1) Checking Oil:

To check oil, set unit upright. Remove pipe plug. With a flashlight, visually inspect the oil in the motor housing to make sure it is clean, clear and that the oil level is above all internal componentry. If oil appears satisfactory, replace pipe plug. If oil is low or appears contaminated, test oil as per section D-1.2

D-1.2) Testing Oil:

1. Place pump on its side, remove pipe plug and drain oil into clean, dry container.
2. Check oil for contamination using an oil tester with a range to 30 kilovolts breakdown.
3. If oil is found to be clean and uncontaminated (measures above 15 kilovolts breakdown), refill the motor housing with oil.
4. If oil is found to be dirty or contaminated (measures below 15 kilovolts breakdown), then the pump must be carefully inspected for leaks at the shaft seal (1), cord inlet (2), square ring and pipe plug before refilling with oil.

D-1.3 Replacing Oil in Motor Housing:

Drain all oil from motor housing and dispose of properly. Refill with 32 ounces of new cooling oil as per Table 1. An air space must remain in the top of the motor housing to compensate for air expansion. Set unit upright and fill only until oil level from top of pipe plug boss is 3" ± 1/4".

WARNING ! - DO NOT overfill oil. Overfilling of motor housing with oil can create excessive and dangerous hydraulic pressure which can destroy the pump and create a hazard. Overfilling oil voids warranty.



TABLE 1 - COOLING OIL - Dielectric

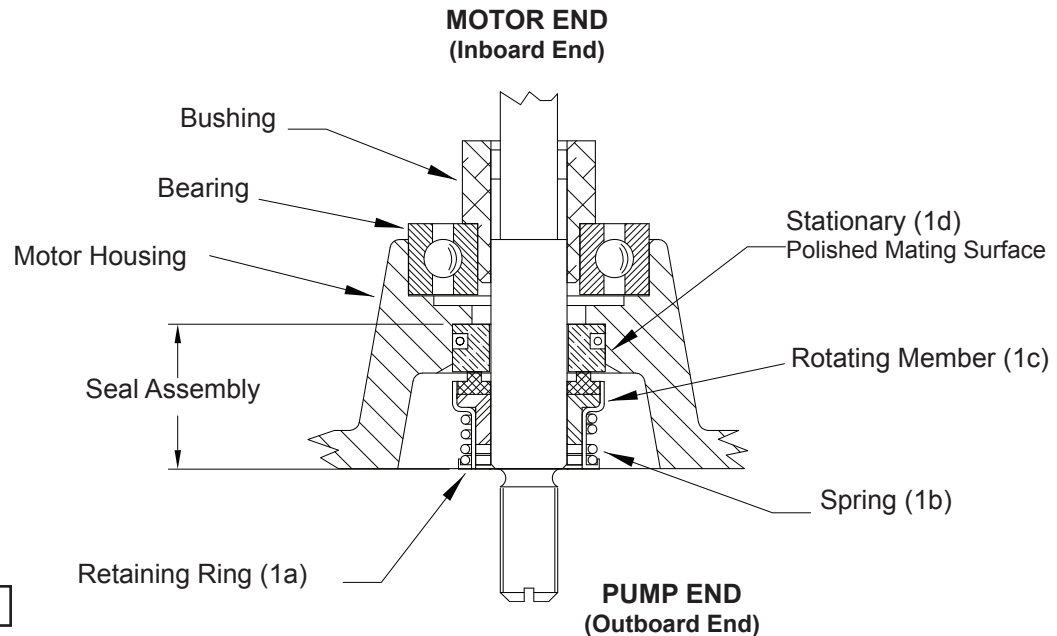

FIGURE 4

SUPPLIER	GRADE
BP	Enerpar SE100
Conoco	Pale Paraffin 22
Mobile	D.T.E. Oil Light
G & G Oil	Circulating 22
Imperial Oil	Voltesso-35
Shell Canada	Transformer-10
Texaco	Diala-Oil-AX
Woco	Premium 100

E-1 SHAFT SEAL SERVICE:

Disconnect power, remove screws and lockwashers, and vertically lift motor assembly from body. Clean out body if necessary. Clean and examine impeller for pitting or wear. The impeller is threaded onto the shaft and to remove, unscrew impeller, holding shaft with a large screwdriver.

CAUTION: - Handle seal parts with extreme care. DO NOT scratch or mar lapped surfaces.



To expose shaft seal (1) disassemble volute and impeller as outlined in above paragraph. Remove rotating member (1b) from shaft (See Fig. 4). Examine all seal parts and especially contact faces. Inspect seal for signs of wear such as uneven wear pattern on stationary members, chips and scratches on either seal face. **DO NOT** interchange seal components, replace the entire shaft seal (1). If replacing seal, remove stationary (1a) by prying out with flat screw driver.

Clean and oil seal cavities in lower motor housing. Lightly oil (DO NOT use grease) outer surface of stationary member (1a). Press stationary member (1a) firmly into lower motor housing, using a seal pusher, nothing but the seal pusher is to come in contact with seal face (See Fig. 5).

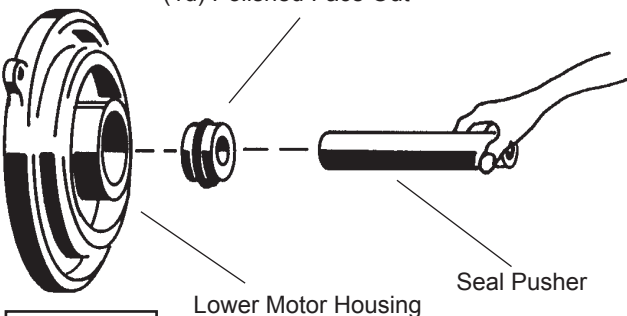

FIGURE 5

oil (DO NOT use grease) outer surface of stationary member (1a). Press stationary member (1a) firmly into lower motor housing, using a seal pusher, nothing but the seal pusher is to come in contact with seal face (See Fig. 5).

IMPORTANT ! - DO NOT hammer on the seal pusher- it will damage the seal face.



Make sure the stationary member is in straight. Slide a

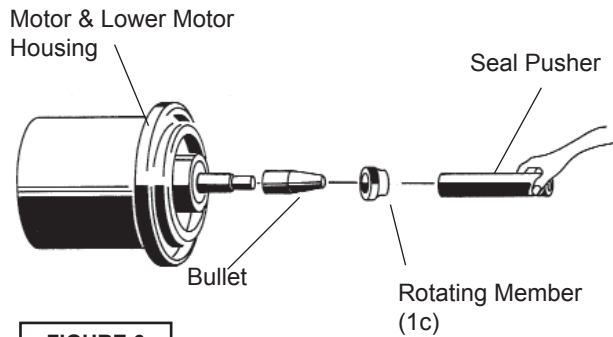

FIGURE 6

bullet (see parts list-seal tool kit) over motor shaft. Lightly oil (DO NOT use grease) shaft, bullet and inner surface of bellows on rotating member (1b) See Fig. 6. With lapped surface of rotating member (1b) facing inward toward stationary member (1a), slide rotating member (1b) over bullet and onto shaft, using seal pusher, until lapped faces of (1a) and (1b) are together (See Fig. 4).

It is extremely important to keep seal faces clean during assembly. Dirt particles lodged between these faces will cause the seal to leak. Place spring (1b) over shaft and in place on rotating member (1c), making sure it is seated. Slide retaining ring (1a) over shaft and let rest on spring (1b).

Before installing impeller, inspect threads on shaft and impeller to assure that they are clean. Apply a thread-locking compound to shaft threads and screw impeller onto shaft and tighten. Rotate impeller to check for binding. Install motor housing assembly on pump body. Apply thread locking compound to each cap screw, thread into body with lockwashers, and torque to 11 ft. lbs. Check for free rotation of impeller. Assemble impeller and volute replace oil

SECTION: F REPLACEMENT PARTS

SINGLE PHASE - 115 VOLTS
MANUAL & AUTOMATIC

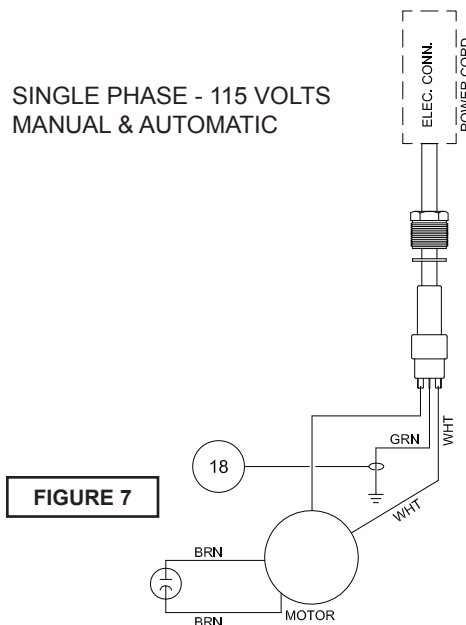



FIGURE 7

F-1 ORDERING REPLACEMENT PARTS:

When ordering replacement parts, ALWAYS furnish the following information:

1. Pump Part Number
2. Pump model number
3. Pump date code

F-2 Part Number:

BARNEL 3 ®		BARNES PUMPS, INC. Mansfield, Ohio	THERMALLY PROTECTED
MODEL	PART No.	MAX AMB. TEMP. 25°C	 CSA 108 UL 778 LR16567
② ○ SEV412	101292	INS. CLASS: B	
○ SEV412A	101293	HP: 0.5	
○ SEV412VF	101294	FLA: 10.5	
○ SEV412AT	103544	RPM: 3450	
○ SEV412VFT	110404	VOLTS: 115	
		HZ: 60	
		PH: 1	
USE WITH APPROVED MOTOR CONTROL THAT MATCHES MOTOR INPUT IN FULL LOAD AMPS & HP. (UTILISER UND? MARREUR APPROUV? CONVENANT AU COURANT? PLEINE CHARGE DU MOTEUR ET HP.)			
		①	
① ② ③ ④ ⑤ ⑥ ⑦ ⑧ ⑨ ⑩ ⑪ ⑫			

105509

BARNEL 3 ®		BARNES PUMPS, INC. Mansfield, Ohio	THERMALLY PROTECTED
MODEL	PART No.	MAX AMB. TEMP. 25°C	 CSA 108 UL 778 LR16567
② ○ EHV412	101298	INS. CLASS: B	
○ EHV412	101298G	HP: 0.5	
○ EHV412A	103542	FLA: 6.4	
○ EHV412AT	103543	RPM: 3450	
		VOLTS: 115	
		HZ: 60	
		PH: 1	
USE WITH APPROVED MOTOR CONTROL THAT MATCHES MOTOR INPUT IN FULL LOAD AMPS & HP. (UTILISER UND? MARREUR APPROUV? CONVENANT AU COURANT? PLEINE CHARGE DU MOTEUR ET HP.)			
		①	
① ② ③ ④ ⑤ ⑥ ⑦ ⑧ ⑨ ⑩ ⑪ ⑫			

105509A

The part number consists of a six (6) digit number, which appears in the catalog. A one or two letter suffix may follow this number to designate the design configuration. This number is used for ordering and obtaining information.

F-2 Model Number:

This designation consists of numbers and letters which represents the horsepower, motor phase and voltage, and pump design. This number is used for ordering and obtaining information.

F-3 Date Code:

The Date Code consists of two numbers which are punched holes in the nameplate. This specifies the month and year which indicates the date the unit was built.

SEV412

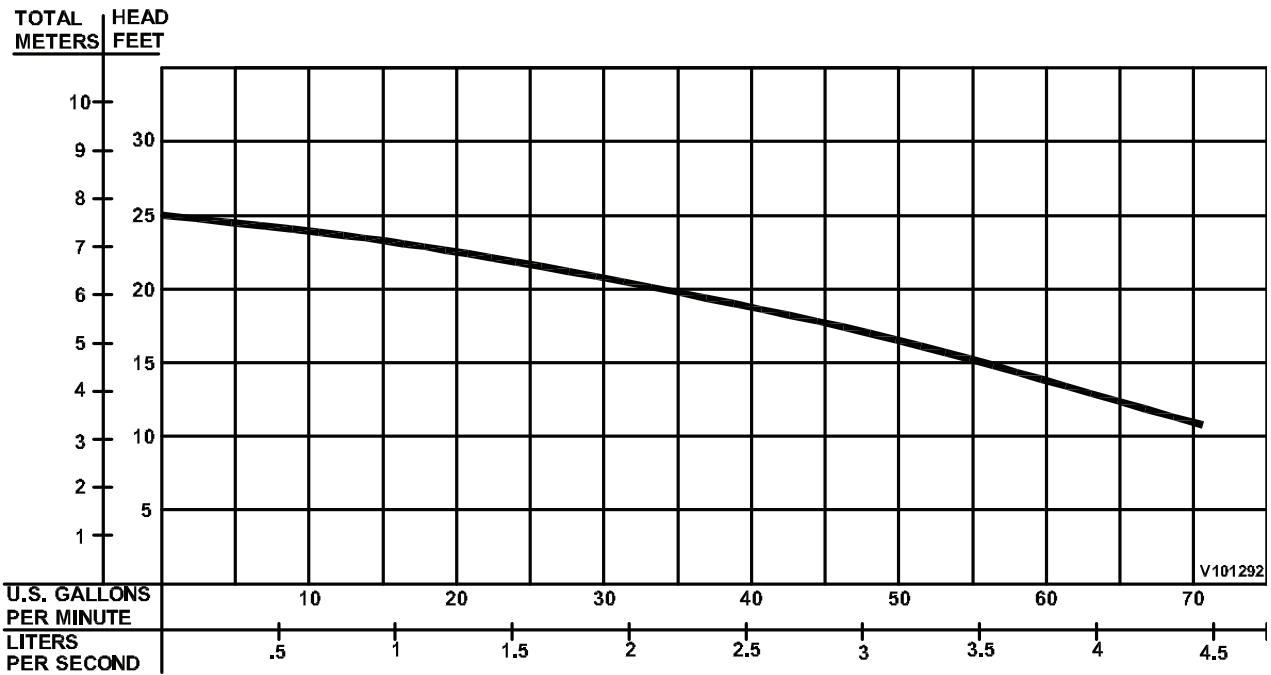

Testing is performed with water specific gravity of 1.0 @ 68°F (20°C), other fluids may vary performance

EHV412

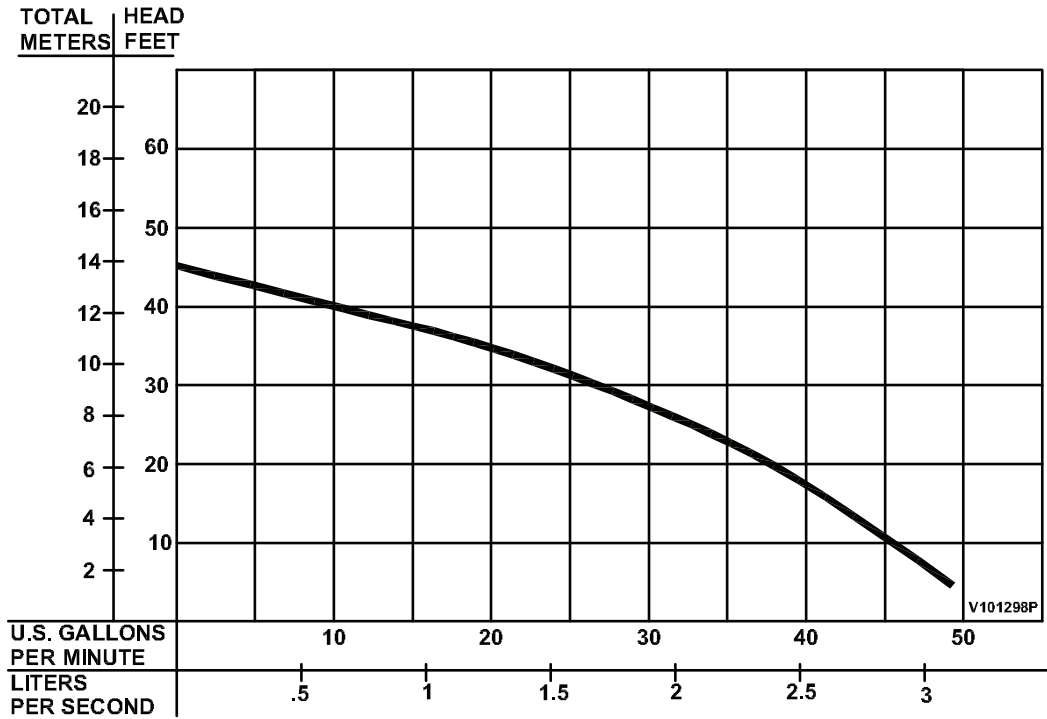

TROUBLE SHOOTING

CAUTION ! Always disconnect the pump from the electrical power source before handling.
 If the system fails to operate properly, carefully read instructions and perform maintenance recommendations.
 If operating problems persist, the following chart may be of assistance in identifying and correcting them:
MATCH “CAUSE” NUMBER WITH CORRELATING “CORRECTION” NUMBER.

NOTE: Not all problems and corrections will apply to each pump model.

PROBLEM	CAUSE	CORRECTION
Pump will not run	<ol style="list-style-type: none"> 1. Poor electrical connection, blown fuse, tripped breaker or other interruption of power, improper power supply. 2. Motor or switch inoperative (to isolate cause, go to manual operation of pump). <ol style="list-style-type: none"> 2a. Float movement restricted. 2b. Switch will not activate pump or is defective. 2c. Defective motor 3. Insufficient liquid level. 	<ol style="list-style-type: none"> 1. Check all electrical connections for security. Have electrician measure current in motor leads, if current is within $\pm 20\%$ of locked rotor Amps, impeller is probably locked. If current is 0, overload may be tripped. Remove power, allow pump to cool, then recheck current. 2a. Reposition pump or clean basin as required to provide adequate clearance for float.
Pump will not turn off	<ol style="list-style-type: none"> 2a. Float movement restricted. 2b. Switch will not activate pump or is defective. 4. Excessive inflow or pump not properly sized for application. 9. Pump may be airlocked 14. H-O-A switch on panel is in “HAND” position 	<ol style="list-style-type: none"> 2b. Disconnect level control. Set ohmmeter for a low range, such as 100 ohms full scale and connect to level control leads. Actuate level control manually and check to see that ohmmeter shows zero ohms for closed switch and full scale for open switch. (Float Switch). 2c. Check winding insulation (Megger Test) and winding resistance. If check is outside of range, dry and recheck. If still defective, replace per service instructions.
Pump hums but does not run	<ol style="list-style-type: none"> 1. Incorrect voltage 8. Impeller jammed or loose on shaft, worn or damaged, impeller cavity or inlet plugged. 	<ol style="list-style-type: none"> 2c. Check winding insulation (Megger Test) and winding resistance. If check is outside of range, dry and recheck. If still defective, replace per service instructions.
Pump delivers insufficient capacity	<ol style="list-style-type: none"> 1. Incorrect voltage. 4. Excessive inflow or pump not properly sized for application. 5. Discharge restricted. 6. Check valve stuck closed or installed backwards. 7. Shut-off valve closed. 8. Impeller jammed or loose on shaft, worn or damaged, impeller cavity or inlet plugged. 9. Pump may be airlocked. 10. Pump running backwards 	<ol style="list-style-type: none"> 3. Make sure liquid level is at least equal to suggested turn-on point. 4. Recheck all sizing calculations to determine proper pump size. 5. Check discharge line for restrictions, including ice if line passes through or into cold areas. 6. Remove and examine check valve for proper installation and freedom of operation. 7. Open valve.
Pump cycles too frequently or runs periodically when fixtures are not in use	<ol style="list-style-type: none"> 6. Check valve stuck closed or installed backwards. 11. Fixtures are leaking. 15. Ground water entering basin. 	<ol style="list-style-type: none"> 8. Check impeller for freedom of operation, security and condition. Clean impeller and inlet of any obstruction. 9. Loosen union slightly to allow trapped air to escape. Verify that turn-off level of switch is set so that the suction is always flooded. Clean vent hole.
Pump shuts off and turns on independent of switch, (trips thermal overload protector). CAUTION! Pump may start unexpectedly. Disconnect power supply.	<ol style="list-style-type: none"> 1. Incorrect voltage. 4. Excessive inflow or pump not properly sized for application. 8. Impeller jammed, loose on shaft, worn or damaged, impeller cavity or inlet plugged. 12. Excessive water temperature. (internal protection only) 	<ol style="list-style-type: none"> 10. Check rotation. If power supply is three phase, reverse any two of three power supply leads to ensure proper impeller rotation.. 11. Repair fixtures as required to eliminate leakage.
Pump operates noisily or vibrates excessively	<ol style="list-style-type: none"> 2c. Worn bearings, motor shaft bent. 8. Debris in impeller cavity or broken impeller 10. Pump running backwards 13. Piping attachments to building structure too rigid or too loose. 	<ol style="list-style-type: none"> 12. Check pump temperature limits & fluid temperature. 13. Replace portion of discharge pipe with flexible connector. 14. Turn to automatic position. 15. Check for leaks around basin inlet and outlets.

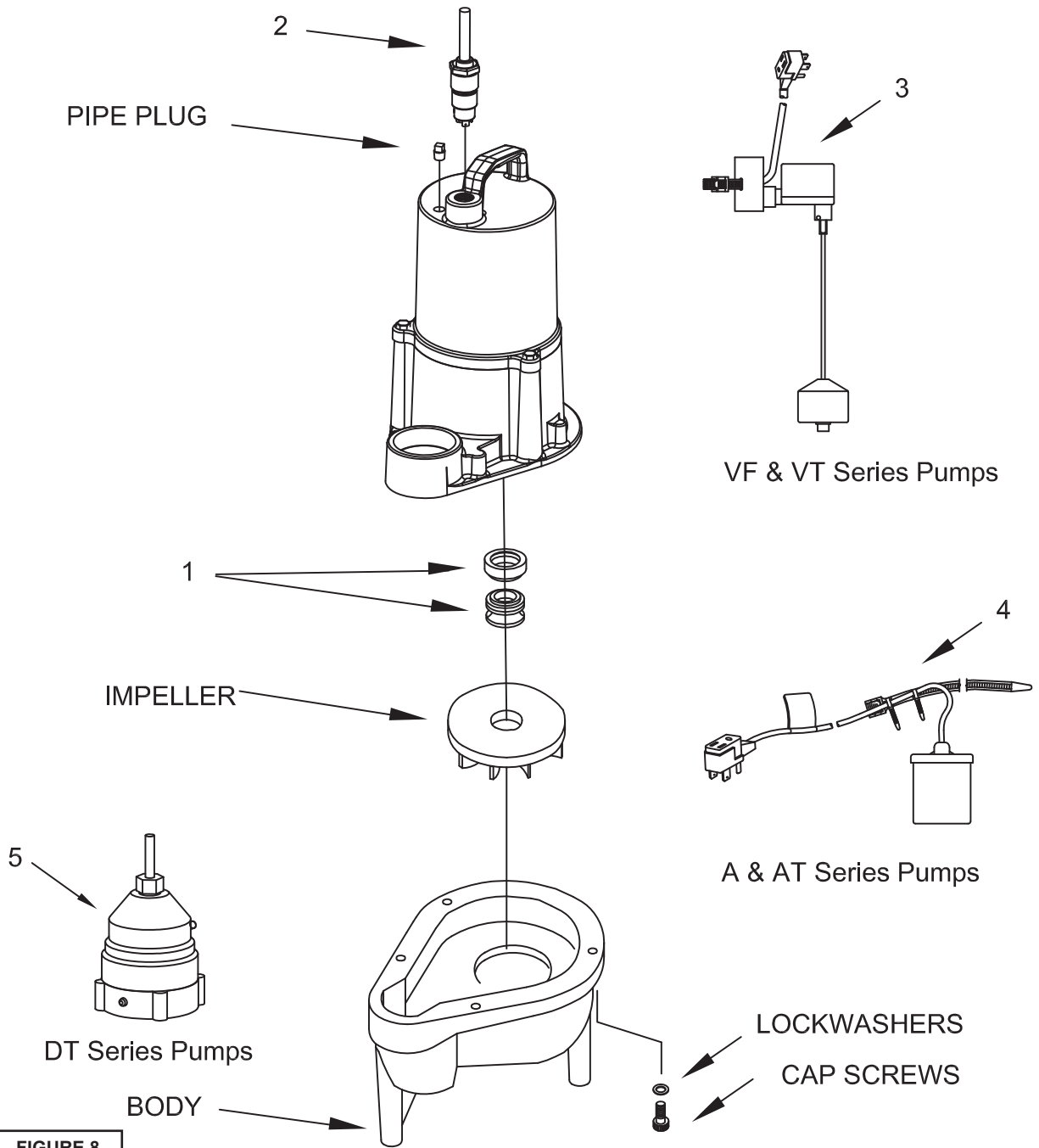

FIGURE 8

PARTS LIST			
ITEM	QTY	DESCRIPTION	PART NO.
1	1	Shaft Seal	128260
2	1	Cord Set Assy, 20 Ft.	099260XA
3	1	Vertical Float, 20 Ft. Cord - VF Series	103476
		Vertical Float, 20 Ft. Cord - VFT Series	103475A
4	1	Wide Angle Float, Piggy-Back Plug	101758XA
5	1	Diaphragm Switch, 20 Ft. Cord - DT Series	135367-20

PUMPS ARE SOLD AS COMPLETE UNITS ONLY, Except for the above listed parts.

BARNES®



burks®

WEINMAN®

DEMING®

PROSSER®

Limited 24 Month Warranty

Crane Pumps & Systems warrants that products of our manufacture will be free of defects in material and workmanship under normal use and service for twenty-four (24) months after manufacture date, when installed and maintained in accordance with our instructions. This warranty gives you specific legal rights, and there may also be other rights which vary from state to state. In the event the product is covered by the Federal Consumer Product Warranties Law (1) the duration of any implied warranties associated with the product by virtue of said law is limited to the same duration as stated herein, (2) this warranty is a LIMITED WARRANTY, and (3) no claims of any nature whatsoever shall be made against us, until the ultimate consumer, his successor, or assigns, notifies us in writing of the defect, and delivers the product and/or defective part(s) freight prepaid to our factory or nearest authorized service station. Some states do not allow limitations on how long an implied warranty lasts, so the above limitation may not apply.

THE SOLE AND EXCLUSIVE REMEDY FOR BREACH OF ANY AND ALL WARRANTIES WITH RESPECT TO ANY PRODUCT SHALL BE TO REPLACE OR REPAIR AT OUR ELECTION, F.O.B. POINT OF MANUFACTURE OR AUTHORIZED REPAIR STATION, SUCH PRODUCTS AND/OR PARTS AS PROVEN DEFECTIVE. THERE SHALL BE NO FURTHER LIABILITY, WHETHER BASED ON WARRANTY, NEGLIGENCE OR OTHERWISE. Unless expressly stated otherwise, guarantees in the nature of performance specifications furnished in addition to the foregoing material and workmanship warranties on a product manufactured by us, if any, are subject to laboratory tests corrected for field performance. Any additional guarantees, in the nature of performance specifications must be in writing and such writing must be signed by our authorized representative. Due to inaccuracies in field testing if a conflict arises between the results of field testing conducted by or for user, and laboratory tests corrected for field performance, the latter shall control. **RECOMMENDATIONS FOR SPECIAL APPLICATIONS OR THOSE RESULTING FROM SYSTEMS ANALYSES AND EVALUATIONS WE CONDUCT WILL BE BASED ON OUR BEST AVAILABLE EXPERIENCE AND PUBLISHED INDUSTRY INFORMATION. SUCH RECOMMENDATIONS DO NOT CONSTITUTE A WARRANTY OF SATISFACTORY PERFORMANCE AND NO SUCH WARRANTY IS GIVEN.**

This warranty shall not apply when damage is caused by (a) improper installation, (b) improper voltage (c) lightning (d) excessive sand or other abrasive material (e) scale or corrosion build-up due to excessive chemical content. Any modification of the original equipment will also void the warranty. We will not be responsible for loss, damage or labor cost due to interruption of service caused by defective parts. Neither will we accept charges incurred by others without our prior written approval.

This warranty is void if our inspection reveals the product was used in a manner inconsistent with normal industry practice and/or our specific recommendations. The purchaser is responsible for communication of all necessary information regarding the application and use of the product. **UNDER NO CIRCUMSTANCES WILL WE BE RESPONSIBLE FOR ANY OTHER DIRECT OR CONSEQUENTIAL DAMAGES, INCLUDING BUT NOT LIMITED TO TRAVEL EXPENSES, RENTED EQUIPMENT, OUTSIDE CONTRACTOR FEES, UNAUTHORIZED REPAIR SHOP EXPENSES, LOST PROFITS, LOST INCOME, LABOR CHARGES, DELAYS IN PRODUCTION, IDLE PRODUCTION, WHICH DAMAGES ARE CAUSED BY ANY DEFECTS IN MATERIAL AND/OR WORKMANSHIP AND/OR DAMAGE OR DELAYS IN SHIPMENT. THIS WARRANTY IS EXPRESSLY IN LIEU OF ANY OTHER EXPRESS OR IMPLIED WARRANTY, INCLUDING ANY WARRANTY OF MERCHANTABILITY OR FITNESS FOR A PARTICULAR PURPOSE.**

No rights extended under this warranty shall be assigned to any other person, whether by operation of law or otherwise, without our prior written approval.

CRANE®

PUMPS & SYSTEMS

A Crane Co. Company

420 Third Street
Piqua, Ohio 45356
(937) 778-8947
Fax (937) 773-7157
www.cranepumps.com

83 West Drive
Brampton, Ont. Canada L6T 2J6
(905) 457-6223
Fax (905) 457-2650

**IMPORTANT!
WARRANTY REGISTRATION**

Your product is covered by the enclosed Warranty.
To complete the Warranty Registration Form go to:

<http://www.cranepumps.com/ProductRegistration/>

If you have a claim under the provision of the warranty, contact your local
Crane Pumps & Systems, Inc. Distributor.

RETURNED GOODS

**RETURN OF MERCHANDISE REQUIRES A "RETURNED GOODS AUTHORIZATION".
CONTACT YOUR LOCAL CRANE PUMPS & SYSTEMS, INC. DISTRIBUTOR.**



**Products Returned Must Be Cleaned, Sanitized,
Or Decontaminated As Necessary Prior To Shipment,
To Insure That Employees Will Not Be Exposed To Health
Hazards In Handling Said Material. All Applicable Laws
And Regulations Shall Apply.**