

BARNES®

INSTALLATION and OPERATION MANUAL Self-Priming Centrifugal Pumps

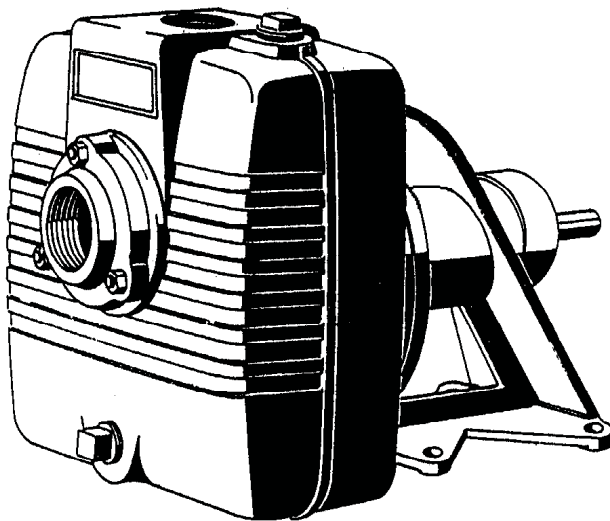

**Universal Drive
Models: 5CU-1
7CU-1**

IMPORTANT!

*Read all instructions in this manual before operating pump.
As a result of Crane Pumps & Systems, Inc., constant product improvement program,
product changes may occur. As such Crane Pumps & Systems reserves the right to
change product without prior written notification.*

CRANE[®]

A Crane Co. Company

PUMPS & SYSTEMS

420 Third Street
Piqua, Ohio 45356
Phone: (937) 778-8947
Fax: (937) 773-7157
www.cranepumps.com

83 West Drive, Bramton
Ontario, Canada L6T 2J6
Phone: (905) 457-6223
Fax: (905) 457-2650

Form No. 022568-Rev. L

TABLE OF CONTENTS

SAFETY FIRST	3
A. PUMP SPECIFICATIONS	4 - 5
B. GENERAL INFORMATION	6
C. INSTALLATION	6
D. OPERATION	7
E. PUMP SERVICE and REPAIR	7
F. REPLACEMENT PARTS.....	7
TRUBLE SHOOTING	8
CROSS-SECTION	9
EXPLODED VIEW	10
PARTS LIST	11
RETURNED GOODS POLICY.....	12
WARRANTY	13
START-UP REPORT	15 - 18
WARRANTY REGISTRATION	

Other brand and product names are trademarks or registered trademarks of their respective holders.

® Barnes is a registered trademark of Crane Pumps & Systems, Inc
1984, 2002, 4/06, 5/06, 8/06

Alteration Rights Reserved

SAFETY FIRST!

Please Read This Before Installing Or Operating Pump.
This information is provided for **SAFETY and to PREVENT EQUIPMENT PROBLEMS**. To help recognize this information, observe the following symbols:



IMPORTANT! Warns about hazards that can result in personal injury or Indicates factors concerned with assembly, installation, operation, or maintenance which could result in damage to the machine or equipment if ignored.

CAUTION ! Warns about hazards that can or will cause minor personal injury or property damage if ignored. Used with symbols below.

WARNING ! Warns about hazards that can or will cause serious personal injury, death, or major property damage if ignored. Used with symbols below.



Hazardous fluids can cause fire or explosions, burnes or death could result.



Extremely hot - Severe burnes can occur on contact.



Biohazard can cause serious personal injury.



Hazardous fluids can Hazardous pressure, eruptions or explosions could cause personal injury or property damage.



Rotating machinery Amputation or severe laceration can result.



Hazardous voltage can shock, burn or cause death.



Toxic Fumes - Breathing can cause nausea, fainting or death



Eye protectiong required

Only qualified personnel should install, operate and repair pump. Any wiring of pumps should be performed by a qualified electrician.



WARNING ! - To reduce risk of electrical shock, pumps and control panels must be properly grounded in accordance with the National Electric Code (NEC) or the Canadian Electrical Code (CEC) and all applicable state, province, local codes and ordinances. Improper grounding voids warranty.



WARNING! - To reduce risk of electrical shock, always disconnect the pump from the power source before handling or servicing. Lock out power and tag.



WARNING! Operation against a closed discharge valve will cause premature bearing and seal failure on any pump, and on end suction and self priming pump the heat build may cause the generation of steam with resulting dangerous pressures. It is recommended that a high case temperature switch or pressure relief valve be installed on the pump body.



CAUTION! Pumps build up heat and pressure during operation-allow time for pumps to cool before handling or servicing.



WARNING! - **DO NOT** pump hazardous materials (flammable, caustic, etc.) unless the pump is specifically designed and designated to handle them.



CAUTION! - Do not block or restrict discharge hose, as discharge hose may whip under pressure.



WARNING! - **DO NOT** wear loose clothing that may become entangled in the impeller or other moving parts. Always wear appropriate safety gear, such as safety glasses, when working on the pump or piping.



WARNING! - Keep clear of suction and discharge openings. **DO NOT** insert fingers in pump with power connected.



Make sure lifting handles are securely fastened each time before lifting. **DO NOT** operate pump without safety devices in place. Always replace safety devices that have been removed during service or repair. Secure the pump in its operating position so it can not tip over, fall or slide.



DO NOT exceed manufacturers recommendation for maximum performance, as this could cause the motor to overheat.



WARNING! Cable should be protected at all times to avoid punctures, cut, bruises and abrasions - inspect frequently. Never handle connected power cords with wet hands.



WARNING! To reduce risk of electrical shock, all wiring and junction connections should be made per the NEC or CEC and applicable state or province and local codes. Requirements may vary depending on usage and location.



WARNING! Products Returned Must Be Cleaned, Sanitized, Or Decontaminated As Necessary Prior To Shipment, To Insure That Employees Will Not Be Exposed To Health Hazards In Handling Said Material. All Applicable Laws And Regulations Shall Apply.

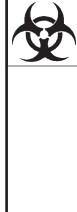

Bronze/brass and bronze/brass fitted pumps may contain lead levels higher than considered safe for potable water systems. Lead is known to cause cancer and birth defects or other reproductive harm. Various government agencies have determined that leaded copper alloys should not be used in potable water applications. For non-leaded copper alloy materials of construction, please contact factory.



IMPORTANT! - Crane Pumps & Systems, Inc. is not responsible for losses, injury, or death resulting from a failure to observe these safety precautions, misuse or abuse of pumps or equipment.

SECTION: A - PUMP SPECIFICATIONS

SUCTION/DISCHARGE. 1½" x 1½" NPT, Female
LIQUID TEMP 160°F (71°C) Continuous
INTERMEDIATE..... Cast Iron ASTM A-48, Class 30
VOLUTE..... Cast Iron ASTM A-48, Class 30
 Removable
BODY Cast Iron ASTM A-48, Class 30
PEDESTAL..... Cast Iron ASTM A-48, Class 30
IMPELLER Design Semi-Open
 Material Cast Iron ASTM A-48, Class 30
 Dynamically Balanced, ISO G6.3
SHAFT..... Stainless Steel
SQUARE RINGS..... Buna-N
HARDWARE 300 Series Stainless Steel
PAINT Air dry enamel
SEAL Design Mechanical
 Lubrication.... Self-Lubricating
 Material Rotating Faces - Carbon
 Stationary Faces - Ceramic
 Elastomer - Buna-N
 Hardware - 300 series stainless steel

BEARING - PUMP END
 Design Single Row, Ball
 Lubrication.... Grease
 Load Radial
BEARING - DRIVE END
 Design Single Row, Ball
 Lubrication.... Grease
 Load Radial
CHECK VALVE:
 Material Valve Flap - Neoprene
 Weight - Cast Iron ASTM A-48, Class 30
OPTIONAL EQUIPMENT: Seal Material, Flex Coupled Assy.
 with Base & OSHA Guard; Right Hand V-Belt Drive Assy.,
 Left Hand V-Belt Drive Assy. and In-Line Vertical V-Belt Drive
 Assy. with Base, Motor Adjusting Base & OSHA Guard.

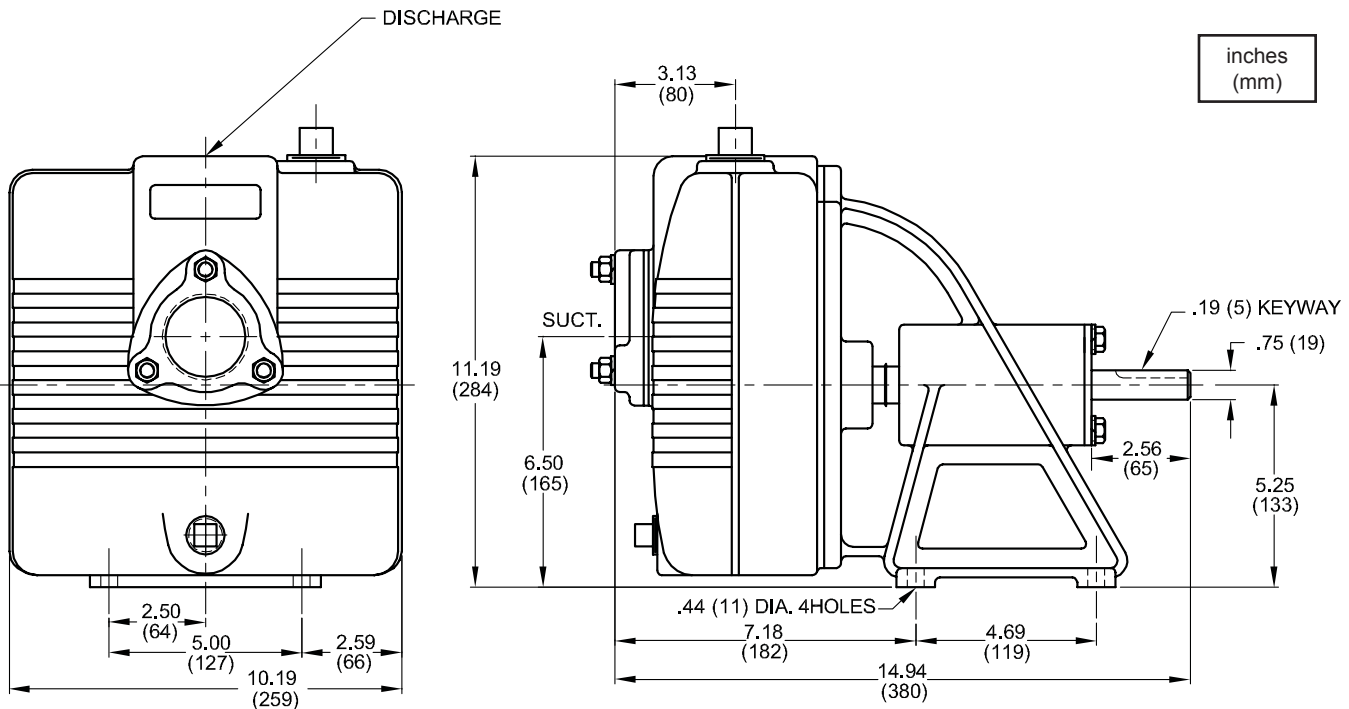

IMPORTANT!

- 1.) **DO NOT** USE FOR PUMPING FLUIDS WITH A FLASH POINT OF LESS THAN 100°F.
- 2.) MAKE CERTAIN THAT PUMP AND/OR MOTOR ASSEMBLY AND CONTROLS HAVE THE APPROPRIATE RATINGS FOR THE GIVEN APPLICATION AREA CLASSIFICATION (ie DIVISION I, AGENCY LISTING ETC.)

SECTION: A - PUMP SPECIFICATIONS

SUCTION/DISCHARGE. 2" x 2" NPT, Female
LIQUID TEMP 160°F (71°C) Continuous
INTERMEDIATE..... Cast Iron ASTM A-48, Class 30
VOLUTE..... Cast Iron ASTM A-48, Class 30
 Removable
BODY..... Cast Iron ASTM A-48, Class 30
PEDESTAL..... Cast Iron ASTM A-48, Class 30
IMPELLERDesign.....Semi-Open
 Material Cast Iron ASTM A-48, Class 30
 Dynamically Balanced, ISO G6.3
SHAFT..... Stainless Steel
SQUARE RINGS..... Buna-N
HARDWARE 300 Series Stainless Steel
PAINT Air dry enamel
SEAL Design..... Mechanical
 Lubrication.... Self-Lubricating
 Material Rotating Faces - Carbon
 Stationary Faces - Ceramic
 Elastomer - Buna-N
 Hardware - 300 series stainless steel

BEARING - PUMP END
 Design..... Single Row, Ball
 Lubrication.... Grease
 Load Radial
BEARING - DRIVE END
 Design..... Single Row, Ball
 Lubrication.... Grease
 Load Radial
CHECK VALVE:
 Material Valve Flap - Neoprene
 Weight - Cast Iron ASTM A-48, Class 30
OPTIONAL EQUIPMENT: Seal Material, Flex Coupled Assy.
 with Base & OSHA Guard; Right Hand V-Belt Drive Assy.,
 Left Hand V-Belt Drive Assy. and In-Line Vertical V-Belt Drive
 Assy. with Base, Motor Adjusting Base & OSHA Guard.

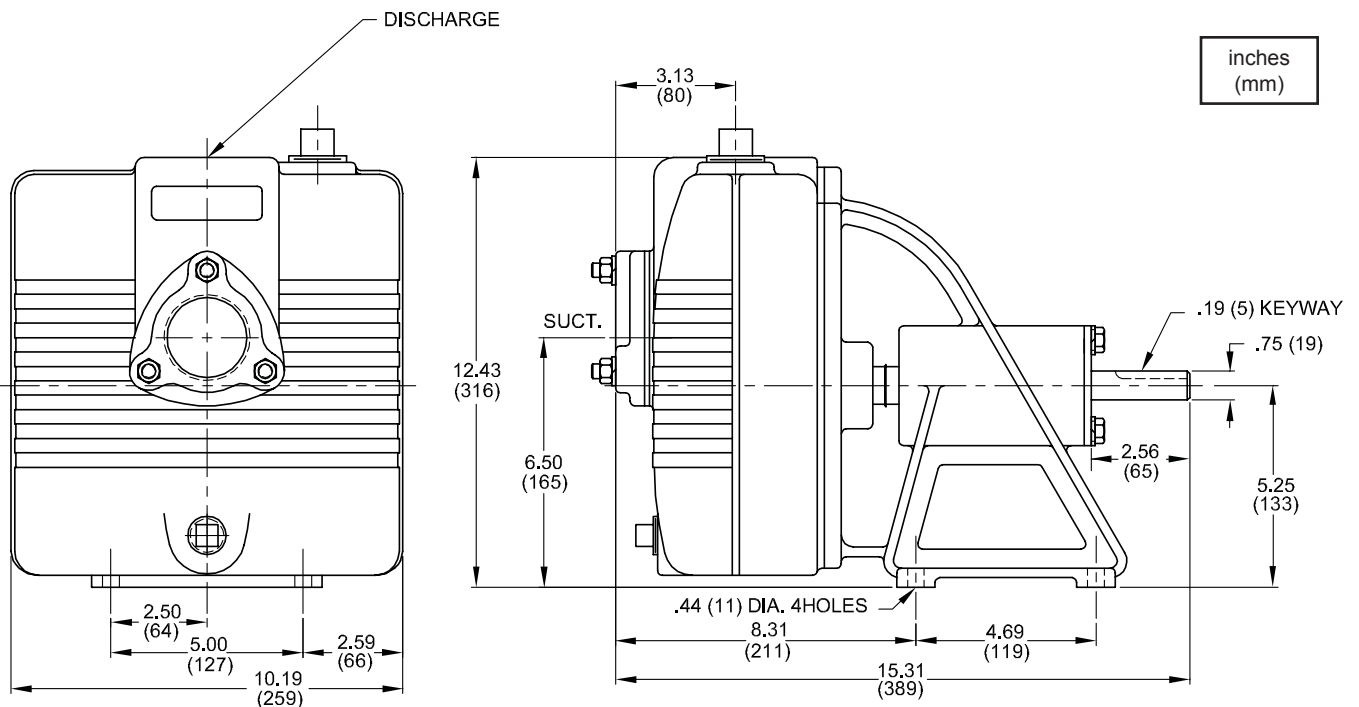

IMPORTANT!

- 1.) **DO NOT USE** FOR PUMPING FLUIDS WITH A FLASH POINT OF LESS THAN 100°F.
- 2.) MAKE CERTAIN THAT PUMP AND/OR MOTOR ASSEMBLY AND CONTROLS HAVE THE APPROPRIATE RATINGS FOR THE GIVEN APPLICATION AREA CLASSIFICATION (ie DIVISION I, AGENCY LISTING ETC.)

SECTION B: GENERAL INFORMATION

B-1) To the Purchaser:

Congratulations! You are the owner of one of the finest pumps on the market today. Barnes products are engineered and manufactured of high quality components. Over one hundred years of pump building experience along with a continuing quality assurance program combine to produce a pump which will stand up to the toughest applications. This manual will provide helpful information concerning installation, maintenance, and proper service guidelines.

B-2) Receiving:

Upon receiving the pump, it should be inspected for damage or shortages. If damage has occurred, file a claim immediately with the company that delivered the pump. If the manual is removed from the packaging, do not lose or misplace.

B-3) Storage:

Short Term- Barnes pump's are manufactured for efficient performance following short inoperative periods in storage. For best results, pumps can be retained in storage, as factory assembled, in a dry atmosphere with constant temperatures for up to six (6) months.

Long Term- Any length of time exceeding six (6) months, but not more than twenty four (24) months. The units should be stored in a temperature controlled area, a roofed over walled enclosure that provides protection from the elements (rain, snow, wind blown dust, etc.), and whose temperature can be maintained between +40 deg. F and +120 deg. F. If extended high humidity is expected to be a problem, all exposed parts should be inspected before storage and all surfaces that have the paint scratched, damaged, or worn should be recoated with a water base, air dry enamel paint. All surfaces should then be sprayed with a rust-inhibiting oil.

Pump should be stored in its original shipping container and on initial start up, rotate impeller by hand to assure seal and impeller rotate freely.

B-4) SERVICE CENTERS:

For the location of the nearest Barnes Service Center, check your Barnes representative or Barnes Service Department in Piqua, Ohio, telephone (937) 778-8947 or Crane Pumps & Systems Canada, Bramton, Ontario (905) 457-6223.

SECTION C: INSTALLATION:

C-1) Location:

The pump should be located as near as possible to the liquid to be pumped and in no case should the pump be more than 25 feet above the surface of the liquid supply. The pump should always be as level as possible.

All pump units rotate clockwise when looking from the driven end of the pump. The impellers are threaded on the shaft and it is necessary to slide one half of the flexible coupling back when checking rotation in order to eliminate the possibility of unscrewing the impeller and damaging the pump.

NOTE: Where impellers thread on pump shaft, never check the direction of electric motor rotation without first disconnecting flexible coupling.

Locate the pump on a firm footing to make sure the pump will not move due to vibration. Flex coupled and V-belt driven units should be permanently grouted onto a cement foundation. The pumps should be level to provide favorable operating conditions. In addition, the flexible coupling should be realigned after grouting in order to eliminate excessive wear on the coupling.

Allow a minimum of 18 inches in front of the pump case cover or hatch cover to permit easy removal and access to the interior of the pump. On belt driven units, allow a minimum of 10 inches at the shaft end to permit easy removal of the pedestal or rotating cartridge.

C-2) Suction System:

It is advisable to use a suction line of the same size as the pump port size. All horizontal suction lines should slope up to the pump to avoid trapped air pockets. An adjustable stand, pipe clamp or floor flange must be installed to support the weight of the suction line. Using a smaller suction line than the pump port size can cause internal damage to the pump.

The suction line must not have holes, even small holes. The smallest air leak in the suction line may prevent the pump from priming. Coat all threaded connections in the suction line with pipe thread compound to insure an air tight joint. In addition, suction flanges should be pulled up tight to prevent air leaks.



CAUTION! - This pump should not be operated without a strainer on the end of the suction line to prevent sticks, stones, rags and other foreign matter from being drawn into the impeller. The strainer should be cleaned regularly to insure full flow.

C-3) Discharge System:

Connect discharge hose or pipe to the side outlet on the discharge tee or to the discharge elbow.

C-4) Driver:

Read Engine Or Motor Manufacturer's Instruction Book.

C-5) Pump Lubrication:

The pump requires no lubrication. The impeller and seal are the only moving parts of the pump and these parts are water lubricated and need no attention.



CAUTION! - DO NOT operate pump without liquid in pump body as operating dry will result in damage to the seal.

SECTION D: OPERATION:

D-1) Priming:

Remove the priming plug in the top of the discharge tee or in top of pump body, and fill the pump body completely with liquid as free of solids as possible. In freezing weather, the pump should be primed with warm water, if possible, to prevent any damage that may be caused by ice films within the pump.

D-2) Starting:

After completion of procedures outlined in Section C and D-1, the pump is then ready for operation. Start pump by applying power to motor or by starting engine as outlined in the **ENGINE or MOTOR INSTRUCTION MANUAL.**

D-3) Shutdown:

Operation may be discontinued by stopping the engine as outlined in the ENGINE MANUAL or by disconnecting electric power if motor driven.

When the pump has been operating in freezing weather or in liquid containing a considerable amount of solids, it is advisable to drain the pump body by removing drain plug (26) and flushing the solids out of the body. Replace the drain plug.

D-4) Restart:

At each subsequent start, particularly if the pump has been drained, the priming liquid level should be checked since the pump is self-priming only when the body is full of liquid.

SECTION E: PUMP SERVICE AND REPAIR:

E-1) Check Valve Service:

To clean out or repair check valve, disconnect suction piping. Remove hex nuts (30) and suction flange (23). **DO NOT PRY ON FLANGE** but rather bump off with a block of wood and a hammer. Pull off gasket (22B) together with weights (22A) and (22E), round head screw (22D) and lock washer (22C). Examine and replace any parts showing wear or damage. When replacing gasket and weight assembly onto pump body make sure that HINGE section of gasket (22B) is at TOP and that LARGE weight is on PUMP SIDE of gasket.

E-2) Body, Volute and Impeller Service:

To clean out or repair the body (18), volute (15) or impeller (12), disconnect suction and discharge piping. Remove hex nuts (21) and lock washers (20) and pull body (18) from pedestal (2). This will expose O-ring (4), impeller (12), volute (15) and volute gasket (17). Examine and replace any part showing undue wear or damage.

When impeller (12) needs replaced, pull volute (15) from pedestal (2) and unscrew the impeller from the shaft (1). The impeller is screwed onto the shaft with right hand thread and to break loose use a block of wood against a vane and strike with a hammer. At reassembly, be sure to use the required number of shims (10) and (11) to result in an impeller-to-volute clearance of not more than .015".

E-3) Shaft Seal Service:

To examine or replace shaft seal, remove body (18) and impeller (12) as outlined in Paragraph E-2. Remove impeller shims (10) and (11). Remove rotating member of shaft seal (9) from shaft (1).

All of the components of the shaft seal are now exposed for examination. If any part shows wear or damage, replace entire shaft seal assembly. When stationary member needs replacing, pry used stationary member from pedestal (2).



CAUTION! - handle seal parts with extreme care. DO NOT scratch or mar lapped faces.

Lightly oil ring and press stationary member over shaft (1) and into pedestal (2). Lightly oil shaft (1) and inner surface of bellows of rotating member. With lapped surface facing pedestal, slide rotating member onto shaft until lapped faces of rotating member and stationary member are together. Reassemble remainder of pump.

E-4) Pedestal and Shaft Service:

To examine or replace shaft (1) or pedestal (2), disassemble as outlined in Paragraph E-2 and E-3.

Remove slinger (3), cap screws (5), lockwashers (6) and pull bearing cap (28) together with shims (27). Remove shaft with assembled bearings. Examine all parts and replace those showing wear or damage.

SECTION: F REPLACEMENT PARTS

F-1 ORDERING REPLACEMENT PARTS:

When ordering replacement parts, ALWAYS furnish the following information:

1. Pump serial number and date code. (F-4)
2. Pump model number. (F-3)
3. Pump part number. (F-2)
4. Part description.
5. Item part number.
6. Quantity required.
7. Shipping instructions.
8. Billing instructions.

BARNES [®]	
Model No. 2	Serial No. 1
Part No. 3	
Impeller Dia.	

036352

F-2 PART NUMBER:

The part number consists of a six (6) digit number, which appears in the catalog. A one or two letter suffix may follow this number to designate the design configuration. This number is used for ordering and obtaining information.

F-3 MODEL NUMBER:

This designation consists of numbers and letters which represent the discharge size, series horsepower, motor phase and voltage, speed and pump design. This number is used for ordering and obtaining information.

F-4 SERIAL NUMBER:

The serial number block will consist of a six digit number, which is specific to each pump and may be preceded by a alpha character, which indicates the plant location. This number will also be suffixed with a four digit number, which indicates the date the unit was built (Date Code). EXAMPLE: A012345 0490.

Reference the six digit portion (Serial Number) of this number when referring to the product.

TROUBLE SHOOTING

CAUTION ! Always disconnect the pump from the electrical power source before handling.
If the system fails to operate properly, carefully read instructions and perform maintenance recommendations.

SYMPTOM	POSSIBLE CAUSE(S)	
Little or no discharge and unit will not prime	<ol style="list-style-type: none"> 1. Casing not filled with water 2. Total head too high 3. Suction head higher than pump designed for 4. Impeller partially or completely plugged 5. Hole or leak in suction line 6. Foot-valve too small 7. Impeller damaged 8. Foot-valve or suction line not submerged deep enough in water; pulling air 9. Insufficient inlet pressure or suction head 10. Suction piping too small 11. Casing gasket leaking 12. Suction or discharge line valves closed 13. Piping is fouled or damaged 14. Clogged strainer or foot-valve 15. Incorrect engine speed 	<ol style="list-style-type: none"> 1. Fill pump casing. Using a foot-valve will extend pump life and facilitate immediate priming 2. Shorten suction head 3. Lower suction head, install foot-valve and prime. 4. Disassemble pump and clean out impeller 5. Repair or replace suction line 6. Match foot-valve to piping or install one size larger foot-valve 7. Disassemble pump and replace impeller 8. Submerge lower in water 9. Increase inlet pressure by adding more water to tank or increasing back pressure by turning gate valve on discharge line partially closed position 10. Increase pipe size to pump inlet size or larger 11. Replace 12. Open 13. Clean or replace 14. Clean or replace 15. Increase speed
Loss of suction after satisfactory operation	<ol style="list-style-type: none"> 1. Air leak in suction line 2. When unit was last turned off, water siphoned out of pump casing 3. Suction head higher than pump designed for 4. Insufficient inlet pressure or suction head 5. Clogged foot-valve, strainer, or pump 6. Defective wearplate(s) 	<ol style="list-style-type: none"> 1. Repair or replace suction line 2. Refill (reprime) pump casing before restarting 3. Lower suction head, install foot-valve and primer 4. Increase inlet pressure by adding more water to tank or increasing back pressure by turning gate valve on discharge line to partially closed position. 5. Unclog, clear or replace as necessary. 6. Replace.
Pump overloads driver	<ol style="list-style-type: none"> 1. Total head lower than pump rating, unit delivering too much water 2. Specific gravity and viscosity of liquid being pumped different than the pump rating 3. Speed to high 	<ol style="list-style-type: none"> 1. Increase back pressure on pump by turning gate valve on discharge line to partially closed position that will not overload motor. 2. Consult factory. 3. Check and correct, lower speed
Pump vibrates and/or makes excessive noise	<ol style="list-style-type: none"> 1. Mounting plate or foundation not rigid enough 2. Foreign material in pump causing unbalance 3. Impeller bent 4. Cavitation present 5. Piping not supported to relieve any strain on pump assembly 	<ol style="list-style-type: none"> 1. Reinforce. 2. Disassemble pump and remove. 3. Replace impeller. 4. Check suction line for proper size and check valve in suction line if completely open, remove any sharp bends before pump and shorten suction line. 5. Make necessary adjustments.
Pump runs but no fluid	<ol style="list-style-type: none"> 1. Faulty suction piping (air leak) 2. Pump located too far from fluid source 3. Gate valve closed 4. Clogged strainer 5. Fouled foot-valve 6. Discharge height too great 7. Fouled impeller 8. Faulty mechanical seal 	<ol style="list-style-type: none"> 1. Replace 2. Replace 3. Open 4. Clean or replace 5. Clean or replace 6. Lower the height 7. Clean or replace. 8. Replace
Pump leaks at shaft	<ol style="list-style-type: none"> 1. Worn mechanical seal 2. Replacement seal not installed properly 	<ol style="list-style-type: none"> 1. Replace 2. Follow Maintenance instructions carefully

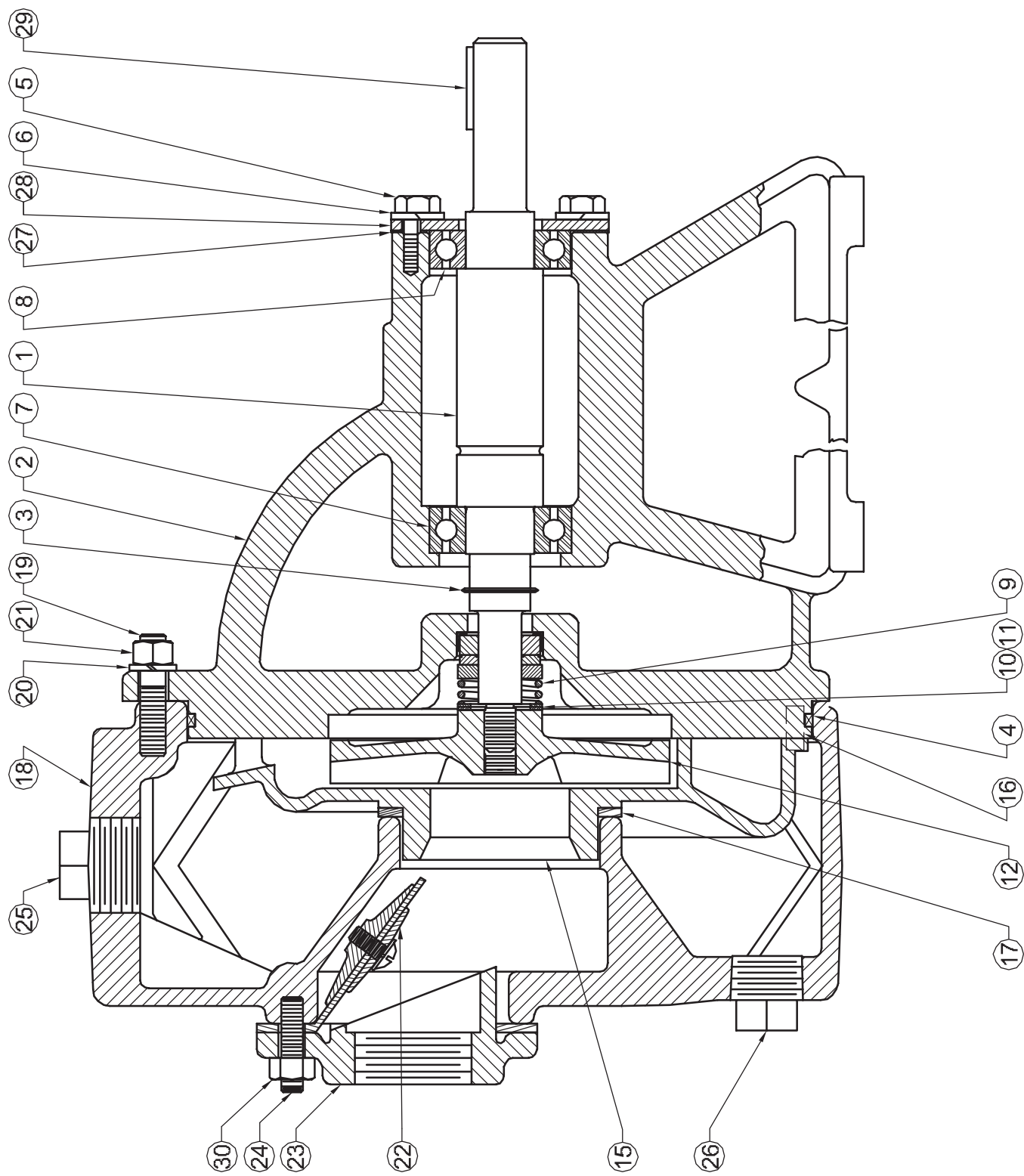

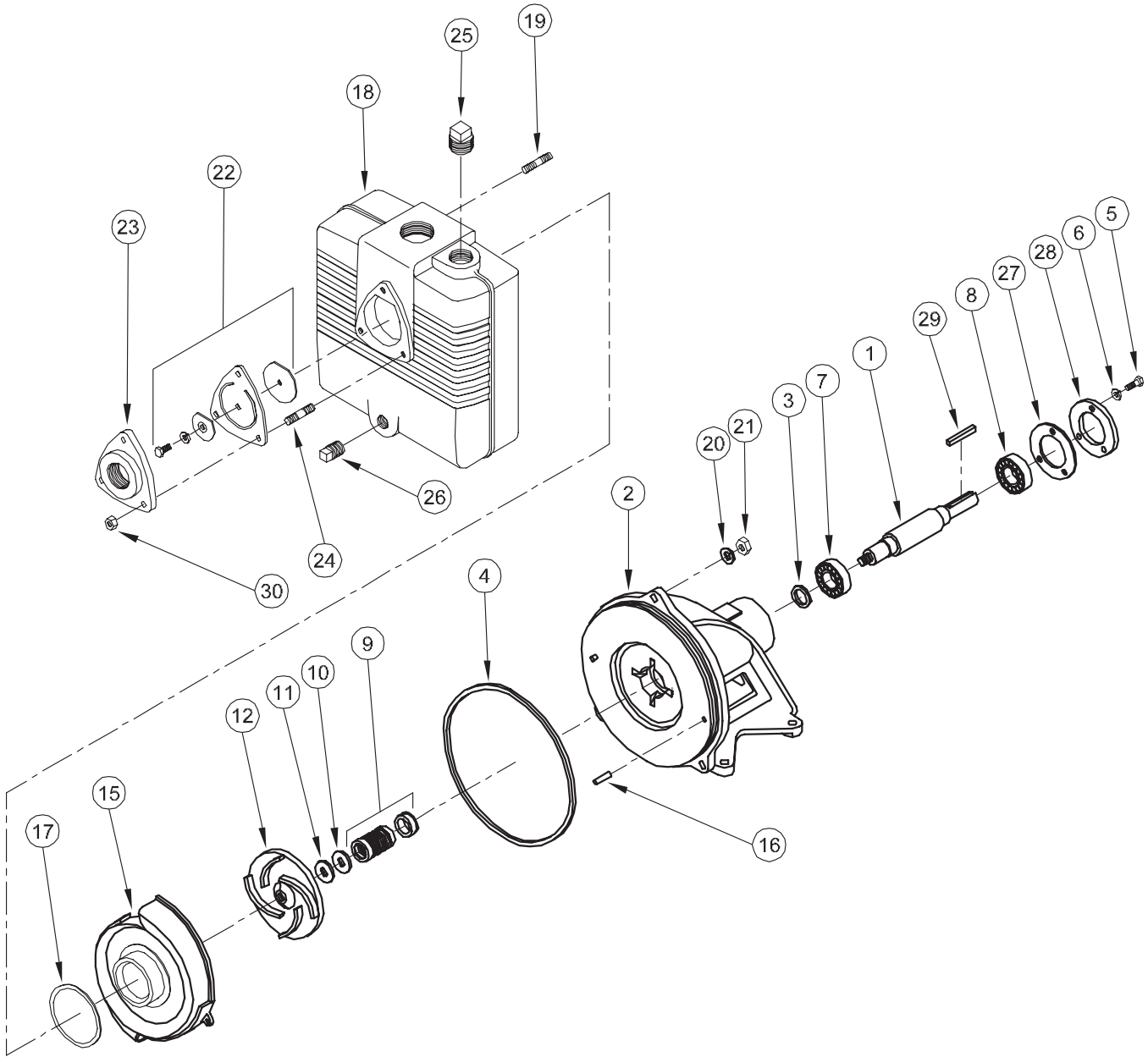

PARTS KIT

Seal Kit P/N: 120742 (†) 3, 4, 9, 10, 11, 16, 17, 22b

ITEM	QTY.	PART No.	DESCRIPTION
1	1	018874	Shaft Stainless
2	1	017805	Pedestal
3	1	018878	† Slinger Buna-N
4	1	017713	† O-Ring
5	3	002201	Hex Hd Screw 1/4-20 x .625" Lg, Steel
6	3	002601	Lockwasher 1/4" Steel
7	1	017807	Bearing
8	1	017807	Bearing
9	1	018873	† Shaft Seal C/C/N
10	1	017064	† Shim, .010
11	1	017109	† Shim, .005
12	1	018094	Impeller 4.87" Dia
15	1	018095	Volute
16	2	017715	† Volute Pin
17	1	017714	† Volute Gasket
18	1	018097	Body 5CU-1
		023723	7CU-1
19	3	018924	Stud 3/8-16 x 1.50" Lg, Stainless
20	3	018926	Lock washer 3/8", Stainless
21	3	15-23-1	Hex Nut 3/8-16, Stainless
22	1	017718	Check Valve Assy
22A	1	001338	Weight 2.50" O.D.
22B	1	017712	† Gasket Neoprene
22C	1	20-13-1	Lock Washer 1/4" Stainless
22D	1	023469	Round Hd Screw 1/4-20 x .625" Lg, Stainless
22E	1	001339	Weight 1.56" O.D.
23	1	018099	Suction Flange 5CU-1
		018100	7CU-1
24	3	018931	Stud, 5CU-1 5/16-18 x 1.25" Lg, Stainless
		018925	Stud, 7CU-1 5/16-18 x 2.25" Lg, Stainless
25	1	003204	Pipe Plug 1.75" NPT
26	1	003206	Pipe Plug 1.25" NPT
27	3	018435	Shim 3" O.D., Bronze
28	1	018434	Bearing Cap
29	1	005017	Key 3/16 Sq. x 1.63" Lg
30	3	15-19-1	Hex Nut 5/16-18, Stainless

BARNES®

BARNES®
PRESSURE **PS** SYSTEMS

CROWN

burks®

WEINMAN®

DEMING®

PROSSER®

Limited 24 Month Warranty

Crane Pumps & Systems warrants that products of our manufacture will be free of defects in material and workmanship under normal use and service for twenty-four (24) months after manufacture date, when installed and maintained in accordance with our instructions. This warranty gives you specific legal rights, and there may also be other rights which vary from state to state. In the event the product is covered by the Federal Consumer Product Warranties Law (1) the duration of any implied warranties associated with the product by virtue of said law is limited to the same duration as stated herein, (2) this warranty is a LIMITED WARRANTY, and (3) no claims of any nature whatsoever shall be made against us, until the ultimate consumer, his successor, or assigns, notifies us in writing of the defect, and delivers the product and/or defective part(s) freight prepaid to our factory or nearest authorized service station. Some states do not allow limitations on how long an implied warranty lasts, so the above limitation may not apply. **THE SOLE AND EXCLUSIVE REMEDY FOR BREACH OF ANY AND ALL WARRANTIES WITH RESPECT TO ANY PRODUCT SHALL BE TO REPLACE OR REPAIR AT OUR ELECTION, F.O.B. POINT OF MANUFACTURE OR AUTHORIZED REPAIR STATION, SUCH PRODUCTS AND/OR PARTS AS PROVEN DEFECTIVE. THERE SHALL BE NO FURTHER LIABILITY, WHETHER BASED ON WARRANTY, NEGLIGENCE OR OTHERWISE.** Unless expressly stated otherwise, guarantees in the nature of performance specifications furnished in addition to the foregoing material and workmanship warranties on a product manufactured by us, if any, are subject to laboratory tests corrected for field performance. Any additional guarantees, in the nature of performance specifications must be in writing and such writing must be signed by our authorized representative. Due to inaccuracies in field testing if a conflict arises between the results of field testing conducted by or for user, and laboratory tests corrected for field performance, the latter shall control. **RECOMMENDATIONS FOR SPECIAL APPLICATIONS OR THOSE RESULTING FROM SYSTEMS ANALYSES AND EVALUATIONS WE CONDUCT WILL BE BASED ON OUR BEST AVAILABLE EXPERIENCE AND PUBLISHED INDUSTRY INFORMATION. SUCH RECOMMENDATIONS DO NOT CONSTITUTE A WARRANTY OF SATISFACTORY PERFORMANCE AND NO SUCH WARRANTY IS GIVEN.**

This warranty shall not apply when damage is caused by (a) improper installation, (b) improper voltage (c) lightning (d) excessive sand or other abrasive material (e) scale or corrosion build-up due to excessive chemical content. Any modification of the original equipment will also void the warranty. We will not be responsible for loss, damage or labor cost due to interruption of service caused by defective parts. Neither will we accept charges incurred by others without our prior written approval.

This warranty is void if our inspection reveals the product was used in a manner inconsistent with normal industry practice and/or our specific recommendations. The purchaser is responsible for communication of all necessary information regarding the application and use of the product. **UNDER NO CIRCUMSTANCES WILL WE BE RESPONSIBLE FOR ANY OTHER DIRECT OR CONSEQUENTIAL DAMAGES, INCLUDING BUT NOT LIMITED TO TRAVEL EXPENSES, RENTED EQUIPMENT, OUTSIDE CONTRACTOR FEES, UNAUTHORIZED REPAIR SHOP EXPENSES, LOST PROFITS, LOST INCOME, LABOR CHARGES, DELAYS IN PRODUCTION, IDLE PRODUCTION, WHICH DAMAGES ARE CAUSED BY ANY DEFECTS IN MATERIAL AND/OR WORKMANSHIP AND/OR DAMAGE OR DELAYS IN SHIPMENT. THIS WARRANTY IS EXPRESSLY IN LIEU OF ANY OTHER EXPRESS OR IMPLIED WARRANTY, INCLUDING ANY WARRANTY OF MERCHANTABILITY OR FITNESS FOR A PARTICULAR PURPOSE.**

No rights extended under this warranty shall be assigned to any other person, whether by operation of law or otherwise, without our prior written approval.



A Crane Co. Company

PUMPS & SYSTEMS

420 Third Street
Piqua, Ohio 45356
(937) 778-8947
Fax (937) 773-7157
www.cranepumps.com

83 West Drive
Brampton, Ont. Canada L6T 2J6
(905) 457-6223
Fax (905) 457-2650

**IMPORTANT!
WARRANTY REGISTRATION**

Your product is covered by the enclosed Warranty.
To complete the Warranty Registration Form go to:

<http://www.cranepumps.com/ProductRegistration/>

If you have a claim under the provision of the warranty, contact your local
Crane Pumps & Systems, Inc. Distributor.

RETURNED GOODS

**RETURN OF MERCHANDISE REQUIRES A "RETURNED GOODS AUTHORIZATION".
CONTACT YOUR LOCAL CRANE PUMPS & SYSTEMS, INC. DISTRIBUTOR.**



**Products Returned Must Be Cleaned, Sanitized,
Or Decontaminated As Necessary Prior To Shipment,
To Insure That Employees Will Not Be Exposed To Health
Hazards In Handling Said Material. All Applicable Laws
And Regulations Shall Apply.**

