

BARNES®

INSTALLATION and OPERATION MANUAL Submersible Non-Clog Pump

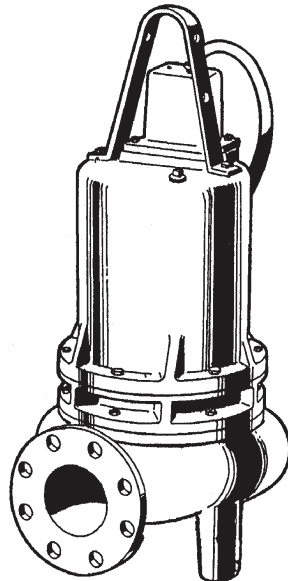
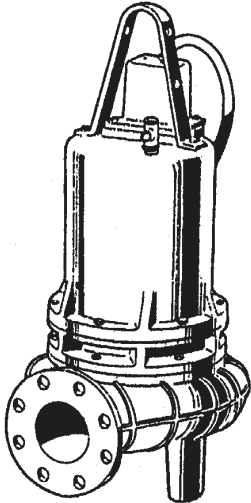

**Series: 4SE-L, 4.5 - 11.3HP
1150RPM, 60Hz**

**Series: 4SE-L, 4.5 - 15HP
1750RPM, 60Hz**

**Series: 4SEU-L, 15HP
1750 & 3450RPM,
60Hz**

**Series: 4SE-HL, 4.5 - 7.5HP
1150RPM, 60Hz**

**Series: 4SE-HL, 7.5 - 15HP
1750RPM, 60Hz**

**Series: 4SE-Z4L, 1.9 - 6.4kW
1450RPM, 50Hz**

IMPORTANT!

Read all instructions in this manual before operating pump.

As a result of Crane Pumps & Systems, Inc., constant product improvement program, product changes may occur. As such Crane Pumps & Systems reserves the right to change product without prior written notification.

CRANE

A Crane Co. Company

PUMPS & SYSTEMS

420 Third Street
Piqua, Ohio 45356
Phone: (937) 778-8947
Fax: (937) 773-7157
www.cranepumps.com

83 West Drive, Bramton
Ontario, Canada L6T 2J6
Phone: (905) 457-6223
Fax: (905) 457-2650



Form No. 084831-Rev. AD

TABLE OF CONTENTS

SAFETY FIRST	3
A. PUMP SPECIFICATIONS	4 - 5
B. GENERAL INFORMATION	6
C. INSTALLATION	6 - 7
ELECTRICAL DATA	8
D. START-UP OPERATION	7
E. PREVENTATIVE MAINTENANCE	9
F. SERVICE and REPAIR	9 - 13
G. REPLACEMENT PARTS.....	14
TROUBLE SHOOTING	15
CROSS-SECTION, 1150 & 1750RPM (Fig. 10).....	16
EXPLODED VIEW, 1150 & 1750RPM (Fig. 11)	17
PARTS LIST	18 - 20
CROSS-SECTION, 3450RPM (Fig. 12).....	21
EXPLODED VIEW, 3450RPM (Fig. 13)	22
PARTS LIST	23 - 24
RETURNED GOODS POLICY.....	25
WARRANT	
START-UP REPORT	
WARRANTY REGISTRATION	
SPECIAL TOOLS AND EQUIPMENT	
INSULATION TESTER (MEGGER)	
DIELECTRIC TESTER	
SEAL TOOL KIT (see parts list)	
PRESSURE GAUGE KIT (see parts list)	

SAFETY FIRST!

Please Read This Before Installing Or Operating Pump.
This information is provided for **SAFETY and to PREVENT EQUIPMENT PROBLEMS**. To help recognize this information, observe the following symbols:



IMPORTANT! Warns about hazards that can result in personal injury or Indicates factors concerned with assembly, installation, operation, or maintenance which could result in damage to the machine or equipment if ignored.

CAUTION ! Warns about hazards that can or will cause minor personal injury or property damage if ignored. Used with symbols below.

WARNING ! Warns about hazards that can or will cause serious personal injury, death, or major property damage if ignored. Used with symbols below.



Hazardous fluids can cause fire or explosions, burnes or death could result.



Extremely hot - Severe burnes can occur on contact.



Biohazard can cause serious personal injury.



Hazardous fluids can Hazardous pressure, eruptions or explosions could cause personal injury or property damage.



Rotating machinery Amputation or severe laceration can result.



Hazardous voltage can shock, burn or cause death.

Only qualified personnel should install, operate and repair pump. Any wiring of pumps should be performed by a qualified electrician.



WARNING ! - To reduce risk of electrical shock, pumps and control panels must be properly grounded in accordance with the National Electric Code (NEC) or the Canadian Electrical Code (CEC) and all applicable state, province, local codes and ordinances.



WARNING! - To reduce risk of electrical shock, always disconnect the pump from the power source before handling or servicing. Lock out power and tag.



WARNING! Operation against a closed discharge valve will cause premature bearing and seal failure on any pump, and on end suction and self priming pump the heat build may cause the generation of steam with resulting dangerous pressures. It is recommended that a high case temperature switch or pressure relief valve be installed on the pump body.



CAUTION ! Never operate a pump with a plug-in type power cord without a ground fault circuit interrupter.



CAUTION! Pumps build up heat and pressure during operation-allow time for pumps to cool before handling or servicing.



WARNING! - **DO NOT** pump hazardous materials (flammable, caustic, etc.) unless the pump is specifically designed and designated to handle them.



Do not block or restrict discharge hose, as discharge hose may whip under pressure.



WARNING! - DO NOT wear loose clothing that may become entangled in the impeller or other moving parts.



WARNING! - Keep clear of suction and discharge openings. **DO NOT** insert fingers in pump with power connected.



Always wear eye protection when working on pumps.



Make sure lifting handles are securely fastened each time before lifting. **DO NOT** operate pump without safety devices in place. Always replace safety devices that have been removed during service or repair. Secure the pump in its operating position so it can not tip over, fall or slide.



DO NOT exceed manufacturers recommendation for maximum performance, as this could cause the motor to overheat.



DO NOT remove cord and strain relief. Do not connect conduit to pump.



WARNING! Cable should be protected at all times to avoid punctures, cut, bruises and abrasions - inspect frequently. Never handle connected power cords with wet hands.



WARNING! To reduce risk of electrical shock, all wiring and junction connections should be made per the NEC or CEC and applicable state or province and local codes. Requirements may vary depending on usage and location.



WARNING! Submersible Pumps are not approved for use in swimming pools, recreational water installations, decorative fountains or any installation where human contact with the pumped fluid is common.



WARNING! Products Returned Must Be Cleaned, Sanitized, Or Decontaminated As Necessary Prior To Shipment, To Insure That Employees Will Not Be Exposed To Health Hazards In Handling Said Material. All Applicable Laws And Regulations Shall Apply.



Bronze/brass and bronze/brass fitted pumps may contain lead levels higher than considered safe for potable water systems. Lead is known to cause cancer and birth defects or other reproductive harm. Various government agencies have determined that leaded copper alloys should not be used in potable water applications. For non-leaded copper alloy materials of construction, please contact factory.



IMPORTANT! - Crane Pumps & Systems, Inc. is not responsible for losses, injury, or death resulting from a failure to observe these safety precautions, misuse or abuse of pumps or equipment.

SECTION: A - PUMP SPECIFICATIONS:
4SE-L and 4SEU-L Pump Models

DISCHARGE 4" 125lb Flange, Horizontal
LIQUID TEMPERATURE . 104°F (40°C) Continuous
MOTOR HOUSING Cast Iron ASTM A-48, Class 30
VOLUTE Cast Iron ASTM A-48, Class 30
SEAL PLATE Cast Iron ASTM A-48, Class 30
IMPELLER:
Design 2 Vane, Open with Pump out vanes on Back side. Dynamically balanced, ISO G6.3
Material Cast Iron ASTM A-48, Class 30
SHAFT 416 Stainless Steel
SQUARE RINGS Buna-N
DIAPHRAGM Buna-N
HARDWARE 300 Series Stainless Steel
LIFTING BAIL 304 Stainless Steel
PAINT Air dry enamel, top coat (Epoxy Optional)
SEAL *Design* Double Mechanical in oil filled pressure equalized reservoir
Material Rotating Faces - Carbon
 Stationary Faces - Ceramic
 Elastomer - Buna-N
 Hardware - 300 series stainless steel
CORD ENTRY 40 Ft. (12.1m) Cord, Epoxy sealed housing with secondary pressure grommet for sealing and strain relief

SPEED 1150, 1750 & 3450RPM, 60Hz (nominal), 1450RPM, 50Hz
BEARINGS:
Upper Single Row, Ball, Oil Lubricated
Load Radial
Lower Single Row, Ball, Oil Lubricated
Load Radial
Life 50,000 HR L10 Design
MOTOR: *Design* NEMA L, Single phase, NEMA B, Three Phase Torque Curve, Oil Filled, Squirrel Cage Induction
Winding Class F, Class H Rated Magnet Wire
Service Factor 1.15
SINGLE PHASE Capacitor Start/Capacitor Run. Requires BARNES Starter/Panel Which includes capacitors and overload protection
THREE PHASE 200-240/480, 60Hz is Tri voltage motor. 380-415, 60Hz Dual voltage. Requires overload protection to be included in control panel, VFD Suitable
MOISTURE SENSOR N/O, Requires relay in control panel
TEMP. SENSOR N/C, Requires relay in control panel
OPTIONAL EQUIPMENT.. Seal Material, Impeller Trims, Additional Cord, Epoxy Paint

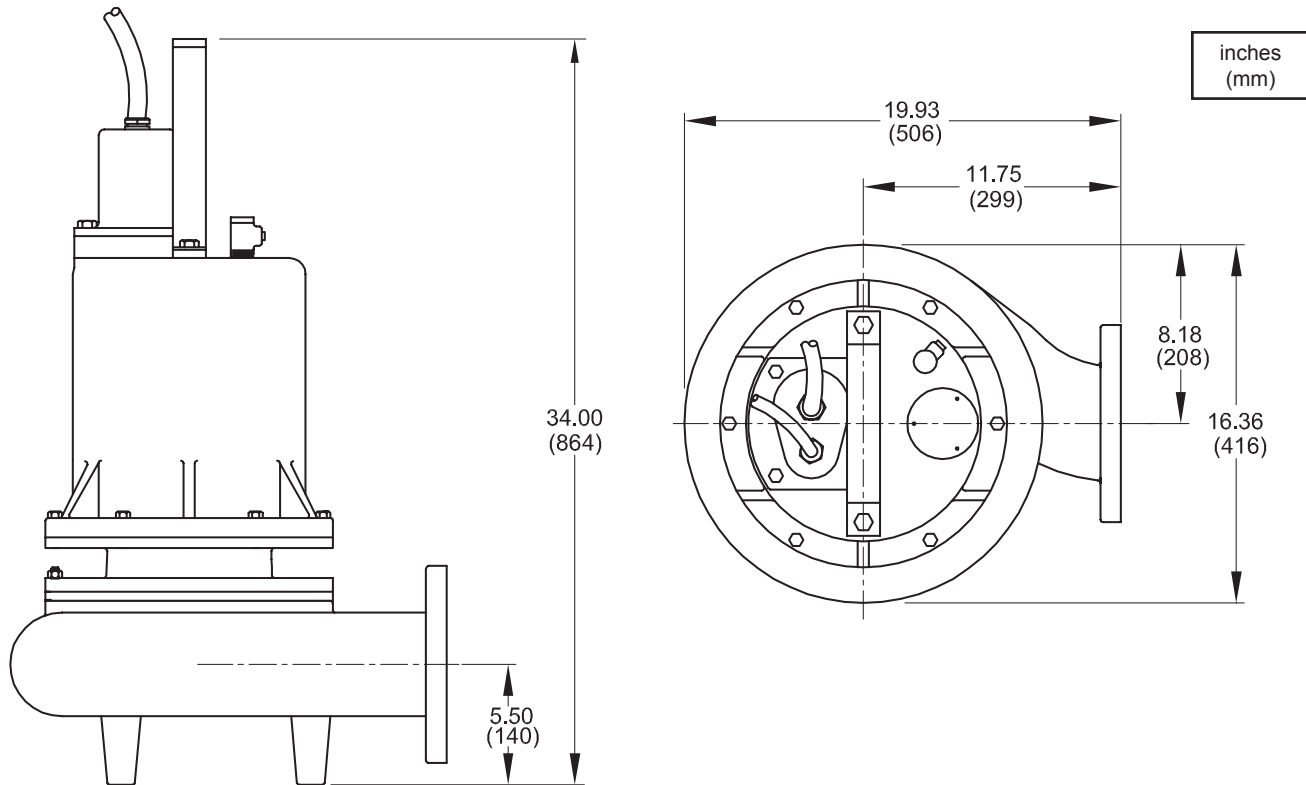

IMPORTANT !

- 1.) PUMP MAY BE OPERATED "DRY" FOR EXTENDED PERIODS WITHOUT DAMAGE TO MOTOR AND/OR SEALS.
- 2.) THIS PUMP IS APPROPRIATE FOR THOSE APPLICATIONS SPECIFIED AS CLASS I DIVISION II HAZARDOUS LOCATIONS.
- 3.) THIS PUMP IS NOT APPROPRIATE FOR THOSE APPLICATIONS SPECIFIED AS CLASS I DIVISION I HAZARDOUS LOCATIONS.
- 4.) INSTALLATIONS SUCH AS DECORATIVE FOUNTAINS OR WATER FEATURES PROVIDED FOR VISUAL ENJOYMENT MUST BE INSTALLED IN ACCORDANCE WITH THE NATIONAL ELECTRIC CODE ANSI/NFPA 70 AND/OR THE AUTHORITY HAVING JURISDICTION. THIS PUMP IS NOT INTENDED FOR USE IN SWIMMING POOLS, RECREATIONAL WATER PARKS, OR INSTALLATIONS IN WHICH HUMAN CONTACT WITH PUMPED MEDIA IS A COMMON OCCURRENCE.

**SECTION: A - PUMP SPECIFICATIONS:
4SE-HL (High Efficiency) Pump Models**

DISCHARGE 4" 125lb Flange, Horizontal
LIQUID TEMPERATURE . 104°F (40°C) Continuous
MOTOR HOUSING Cast Iron ASTM A-48, Class 30
VOLUTE Cast Iron ASTM A-48, Class 30
 with Bronze Wear Ring
SEAL PLATE Cast Iron ASTM A-48, Class 30
IMPELLER:
 Design 2 Vane, Enclosed with Pump out
 vanes on Back side. Dynamically
 balanced, ISO G6.3
 Material Cast Iron ASTM A-48, Class 30
SHAFT 416 Stainless Steel
SQUARE RINGS Buna-N
DIAPHRAGM Buna-N
HARDWARE 300 Series Stainless Steel
LIFTING BAIL 304 Stainless Steel
PAINT Air dry enamel, top coat
 (Epoxy Optional)
SEAL *Design* Double Mechanical in oil filled
 pressure equalized reservoir
 Material Rotating Faces - Carbon
 Stationary Faces - Ceramic
 Elastomer - Buna-N
 Hardware - 300 series stainless steel
CORD ENTRY 40 Ft. (12.1m) Cord, Epoxy sealed
 housing with secondary pressure
 grommet for sealing and strain relief

SPEED 1150 & 1750RPM, 60Hz (nominal)
BEARINGS:
 Upper Single Row, Ball, Oil Lubricated
 Load Radial
 Lower Single Row, Ball, Oil Lubricated
 Load Radial
 Life 50,000 HR L10 Design
MOTOR: *Design* NEMA L, Single phase,
 NEMA B, Three Phase Torque Curve,
 Oil Filled, Squirrel Cage Induction
 Winding Class F, Class H Rated Magnet Wire
 Service Factor 1.15
SINGLE PHASE Capacitor Start/Capacitor Run.
 Requires BARNES Starter/Panel
 Which includes capacitors and
 overload protection
THREE PHASE Tri voltage 200-240/480, 1150RPM;
 Dual Voltage 240/480, 1750RPM;
 Requires overload protection
 to be included in control panel, VFD
 Suitable
MOISTURE SENSOR N/O, Requires relay in control panel
TEMP. SENSOR N/C, Requires relay in control panel
OPTIONAL EQUIPMENT . Seal Material, Impeller Trims,
 Additional Cord, Epoxy Paint

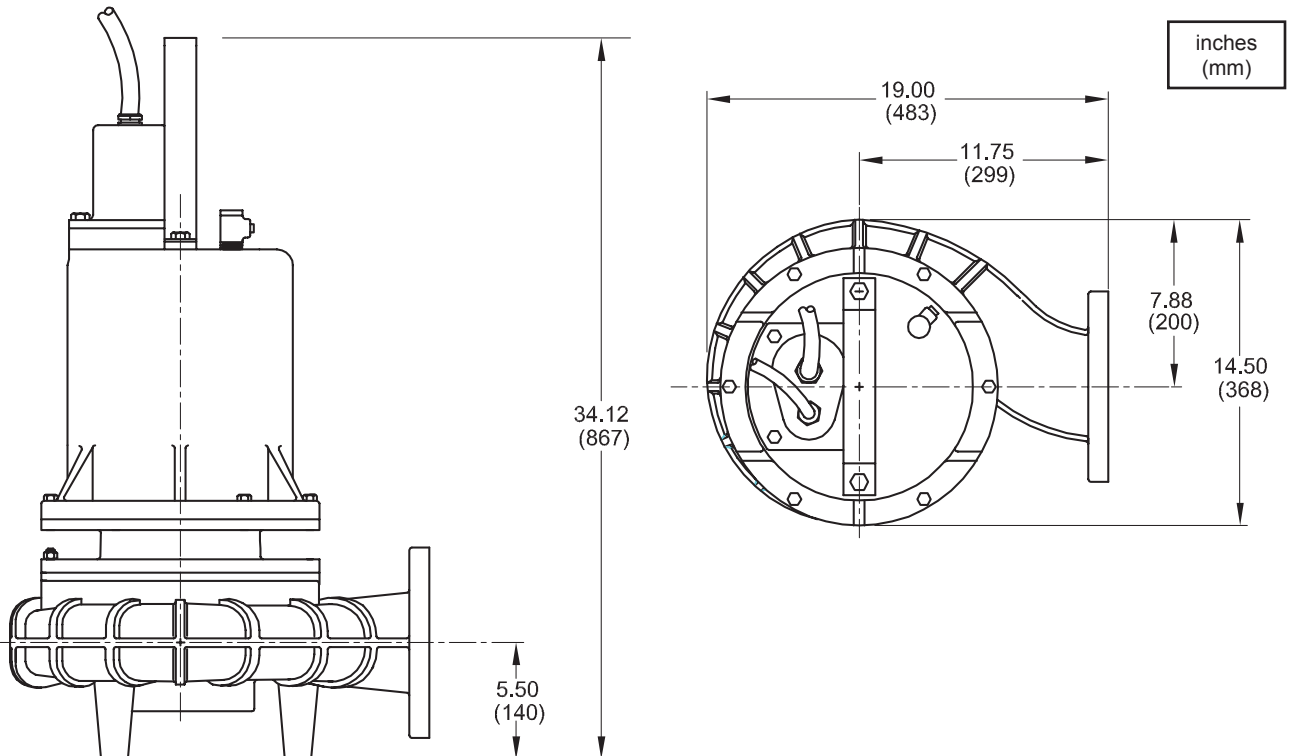

IMPORTANT !

- 1.) PUMP MAY BE OPERATED "DRY" FOR EXTENDED PERIODS WITHOUT DAMAGE TO MOTOR AND/OR SEALS.
- 2.) THIS PUMP IS APPROPRIATE FOR THOSE APPLICATIONS SPECIFIED AS CLASS I DIVISION II HAZARDOUS LOCATIONS.
- 3.) THIS PUMP IS NOT APPROPRIATE FOR THOSE APPLICATIONS SPECIFIED AS CLASS I DIVISION I HAZARDOUS LOCATIONS.
- 4.) INSTALLATIONS SUCH AS DECORATIVE FOUNTAINS OR WATER FEATURES PROVIDED FOR VISUAL ENJOYMENT MUST BE INSTALLED IN ACCORDANCE WITH THE NATIONAL ELECTRIC CODE ANSI/NFPA 70 AND/OR THE AUTHORITY HAVING JURISDICTION. THIS PUMP IS NOT INTENDED FOR USE IN SWIMMING POOLS, RECREATIONAL WATER PARKS, OR INSTALLATIONS IN WHICH HUMAN CONTACT WITH PUMPED MEDIA IS A COMMON OCCURRENCE.

SECTION B: GENERAL INFORMATION

B-1) To the Purchaser:

Congratulations! You are the owner of one of the finest pumps on the market today. CP&S pumps are products engineered and manufactured of high quality components. Over one hundred years of pump building experience along with a continuing quality assurance program combine to produce a pump which will stand up to the toughest applications. This manual will provide helpful information concerning installation, maintenance, and proper service guidelines.

B-2) Receiving:

Upon receiving the pump, it should be inspected for damage or shortages. If damage has occurred, file a claim immediately with the company that delivered the pump. If the manual is removed from the packaging, do not lose or misplace.

B-3) Storage:

Short Term- CP&S Pumps are manufactured for efficient performance following short inoperative periods in storage. For best results, pumps can be retained in storage, as factory assembled, in a dry atmosphere with constant temperatures for up to six (6) months. **Long Term-** Any length of time exceeding six (6) months, but not more than twenty-four (24) months. The unit should be stored in a temperature controlled area, a roofed over walled enclosure that provides protection from the elements (rain, snow, wind-blown dust, etc.), and whose temperature can be maintained between +40 deg. F and +120 deg. F. (4.4 - 49°C). Pump should be stored in its original shipping container. On initial start up, rotate impeller by hand to assure seal and impeller rotate freely. If it is required that the pump be installed and tested before the long term storage begins, such installation will be allowed provided:

- 1.) The pump is not installed under water for more than one (1) month.
- 2.) Immediately upon satisfactory completion of the test, the pump is removed, thoroughly dried, repacked in the original shipping container, and placed in a temperature controlled storage area.

B-4) Service Centers:

For the location of the nearest Barnes Service Center, check your Barnes representative or Crane Pumps & Systems Service Department in Piqua, Ohio, telephone (937) 778-8947 or Crane Pumps & Systems Canada, in Brampton, Ontario, (905) 457-6223.

SECTION C: INSTALLATION

C-1) Location:

These pumping units are self-contained and are recommended for use in a sump, lift station or basin. This pump is designed to pump sewage, effluent, or other nonexplosive or noncorrosive wastewater and shall NOT be installed in locations classified as hazardous in accordance with the National Electrical Code (NEC), ANSI/NFPA 70 or Canadian Electrical Code. Never install the pump in a trench, ditch or hole with a dirt bottom; the legs will sink into the dirt and the suction will become plugged.

C-1.1 Submergence:

It is recommended that the pump be operated in the submerged condition and the sump liquid level should never be less than dimension "A" in Figure 1.

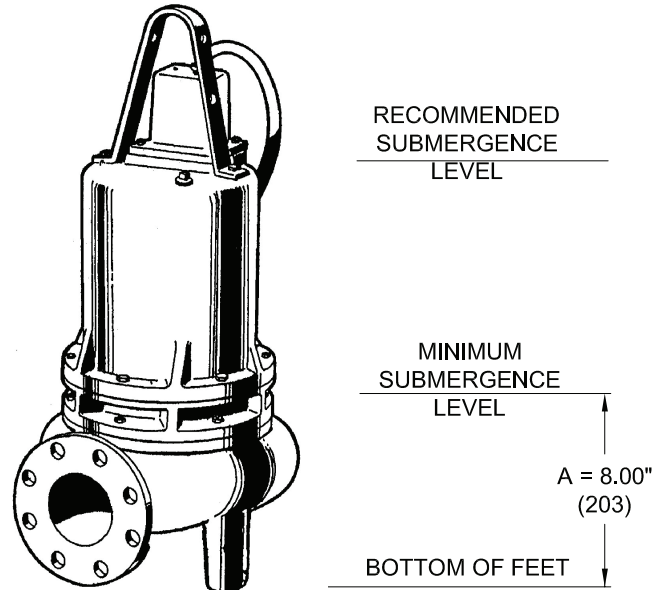

FIGURE 1

C-2) Discharge:

Discharge piping should be as short as possible. Both a check valve and a shut-off valve are recommended for each pump being used. The check valve is used to prevent backflow into the sump. Excessive backflow can cause flooding and/or damage to the pump. The shut-off valve is used to stop system flow during pump or check valve servicing.

Barnes supplies a breakaway fitting discharge system designed to allow the submersible wastewater pump to be installed or removed without requiring personnel to enter the wet well.

Place the Break Away Fitting (BAF) in position. Temporarily secure the guide rails in the upper mounting brackets and locate the base on the bottom of the wet well. Level the base with grout and/or shims. Install the intermediate support brackets, if required. Make sure the rails are in a true vertical position so the pump will clear the access opening and will slide freely down the rails into place on the discharge stationary fitting. Once the rails are in proper alignment, bolt the base into the floor of the station and connect the discharge pipe to the elbow. Connect the movable portion and other supplied fittings of the BAF onto the pump and lower into wet well. See the Break Away Fitting manual for more information.

C-3) Liquid Level Controls:

The level controls are to be supported by a mounting bracket that is attached to the sump wall, cover or junction box. Cord grips are used to hold the cords in place on the mounting bracket. The control level can be changed by loosening the grip and adjusting the cord length as per the plans and specifications. Be certain that the level controls cannot hang up or foul in it's swing and that the pump is completely submerged when the level control is in the "Off" mode.

C-4) Electrical Connections:

C-4.1) Power & Control Cords:

The cord assembly mounted to the pump must not be modified in any way except for shortening to a specific application. Any splice between the pump and the control panel must be made in accordance with all applicable electric codes. It is recommended that a junction box, if used, be mounted outside the sump or be of at least Nema 4 (EEMAC-4) construction if located within the wet well. **DO NOT USE THE POWER OR CONTROL CORDS TO LIFT PUMP.**

NOTE: The White Wire Is Not A Neutral Or Ground Lead. The Black, White And Red Leads Are Power Carrying Conductors. The Green Lead Is For Connection To Ground.

C-4.2) Overload Protection :

C-4.2-1) Three Phase - The normally closed (N/C) thermal sensor is embedded in the motor windings and will detect excessive heat in the event an overload condition occurs. The thermal sensor will trip when the windings become too hot and will automatically reset itself when the pump motor cools to a safe temperature. It is recommended that the thermal sensor be connected in series to an alarm device to alert the operator of an overload condition, and/or the motor starter coil to stop the pump. In the event of an overload, the source of this condition should be determined and rectified immediately. **DO NOT LET THE PUMP CYCLE OR RUN IF AN OVERLOAD CONDITION OCCURS !**

C-4.2-2) Single Phase - The type of in-winding overload protector used is referred to as an inherent overheating protector and operates on the combined effect of temperature and current. This means that the overload protector will trip out and shut the pump off if the windings become too hot, or the load current passing through them becomes too high. It will then automatically reset and start the pump up after the motor cools to a safe temperature. In the event of an overload, the source of this condition should be determined and rectified immediately. **DO NOT LET THE PUMP CYCLE OR RUN IF AN OVERLOAD CONDITION OCCURS !**

NOTE: Single phase pumps can be ordered with an optional Thermal Sensor as well as the standard in winding overload protection.

C-4.3) Moisture Sensors:

A normally open (N/O) detector is installed in the pump seal chamber which will detect any moisture present. It is recommended that this detector be connected in series to an alarm device or the motor starter coil to alert the operator that a moisture detect has occurred. In the event of a moisture detect, check the individual moisture sensor probe leads for continuity, (∞ resistance = no moisture) and the junction box/control box for moisture content. The above situations may induce a false signal in the moisture detecting circuit. If none of the above test prove conclusive, the pump(s) should be pulled and the source of the failure identified and repaired. **IF A MOISTURE DETECT HAS OCCURRED SCHEDULE MAINTENANCE AS SOON AS POSSIBLE.**

C-4.4) Wire Size:

Consult a qualified electrician for proper wire size if additional power cable is required. See table for electrical information.

TEMPERATURE SENSOR ELECTRICAL RATINGS		
Volts	Continuous Amperes	Inrush Amperes
110-120	3.00	30.0
220-240	1.50	15.0
440-480	0.75	7.5
600	0.60	6.0

SECTION: D START-UP OPERATION

D-1) Check Voltage and Phase:

Before operating pump, compare the voltage and phase information stamped on the pump identification plate to the available power.

D-2) Check Pump Rotation:

Before putting pump into service for the first time, the motor rotation must be checked. Improper motor rotation can result in poor pump performance and can damage the motor and/or pump. To check the rotation, suspend the pump freely, momentarily apply power and observe the "kickback". "Kickback" should always be in a counter-clockwise direction as viewed from the top of the pump motor housing.

D-2.1) Incorrect Rotation for Three-Phase Pumps:

In the event that the rotation is incorrect for a three-phase installation, interchange any two power cable leads at the control box. **DO NOT** change leads in the cable housing in the motor. Recheck the "kickback" rotation again by momentarily applying power.

D-2.2) Incorrect Rotation for Single-Phase Pumps:

In the unlikely event that the rotation is incorrect for a single phase pump, contact a Barnes Service Center.

D-3) Start-Up Report:

Included at the end of this manual is a start-up report sheet, this sheet is to be completed as applicable. Return one copy to Barnes and store the second in the control panel or with the pump manual if no control panel is used. It is important to record this data at initial start-up since it will be useful to refer to should servicing the pump be required in the future.

D-3.1) Identification Plate:

Record the numbers from the pump identification plate on both START-UP REPORTS provided at the end of the manual for future reference.

D-3.2) Insulation Test:

Before the pump is put into service, an insulation (megger) test should be performed on the motor. The resistance values (ohms) as well as the voltage (volts) and current (amps) should be recorded on the start-up report.

D-3.3) Pump-Down Test:

After the pump has been properly wired and lowered into the basin, sump or lift station, it is advisable to check the system by filling with liquid and allowing the pump to operate through its pumping cycle. The time needed to empty the system, or pump-down time along with the volume of water, should be recorded on the start-up report.

MODEL NO	HP (kW)	VOLT	PH	RPM (Nom)	NEMA START CODE	FULL LOAD AMPS	LOCKED ROTOR AMPS	CORD SIZE	CODE TYPE	CORD O.D. ± .02 (-.5) in (mm)	WINDING RESISTANCE MAIN -- START
4SEU15034L	15	230	3	1750	D	38.0	160.0	6/4	SOW	1.06	0.35
4SEU15044L	15	460	3	1750	D	19.0	80.0	6/4	SOW	1.06	1.45
4SEU15054L	15	575	3	1750	D	15.2	63.8	10/4	SOW	0.75	2.20
4SEU15032L	15	230	3	3450	D	38.0	160.0	6/4	SOW	1.06	0.23
4SEU15042L	15	460	3	3450	D	19.0	80.0	6/4	SOW	1.06	0.91
4SEU15052L	15	575	3	3450	D	15.2	63.8	10/4	SOW	0.75	1.30
4SE4526L	4.5	230	1	1150	E	22.0	95.0	10/4	SOW	0.75	1.00 -- 0.88
4SE4596L	4.5	200-230	3	1150	C/G	16.6/14.4	51.3/64.0	10/4	SOW	0.75	1.24
4SE4546L	4.5	460	3	1150	F	7.2	29.5	10/4	SOW	0.75	4.96
4SE4556L	4.5	575	3	1150	F	5.7	23.6	10/4	SOW	0.75	----
4SE7596L	7.5	200-230	3	1150	B/E	25.3/22.0	74.8/86.0	8/4	SOW	0.83	0.86
4SE7546L	7.5	460	3	1150	E	11.0	43.0	8/4	SOW	0.83	3.44
4SE7556L	7.5	575	3	1150	E	8.8	34.4	10/4	SOW	0.75	----
4SE11396L	11.3	200-230	3	1150	B/D	32.2/28.0	107.8/124	8/4	SOW	0.83	0.75
4SE11346L	11.3	460	3	1150	D	14.0	62.0	8/4	SOW	0.83	2.99
4SE11356L	11.3	575	3	1150	D	11.2	49.6	10/4	SOW	0.75	----
4SE4524L	4.5	230	1	1750	A	26.0	59.0	10/4	SOW	0.75	0.30 -- 1.20
4SE4564L	4.5	200	3	1750	C	20.9	48.6	10/4	SOW	0.75	0.71
4SE4534L	4.5	230	3	1750	E	18.2	56.0	10/4	SOW	0.75	1.43
4SE4544L	4.5	460	3	1750	E	9.1	28.0	10/4	SOW	0.75	5.71
4SE4554L	4.5	575	3	1750	E	7.2	22.4	10/4	SOW	0.75	----
4SE7524L	7.5	230	1	1750	A	39.0	96.0	6/4	SOW	1.06	0.5 -- 2.20
4SE7564L	7.5	200	3	1750	B	30.8	69.5	8/4	SOW	0.83	0.43
4SE7534L	7.5	230	3	1750	D	26.8	80.0	8/4	SOW	0.83	0.71
4SE7544L	7.5	460	3	1750	D	13.4	40.0	8/4	SOW	0.83	2.85
4SE7554L	7.5	575	3	1750	D	10.7	32.0	10/4	SOW	0.75	----
4SE11364L	11.3	200	3	1750	B	32.2	109.5	8/4	SOW	0.83	0.35
4SE11334L	11.3	230	3	1750	D	28.0	126.0	8/4	SOW	0.83	0.43
4SE11344L	11.3	460	3	1750	D	14.0	63.0	8/4	SOW	0.83	1.72
4SE11354L	11.3	575	3	1750	D	11.2	50.4	10/4	SOW	0.75	----
4SE15034L	15	230	3	1750	D	38.0	160.0	6/4	SOW	1.06	0.35
4SE15044L	15	460	3	1750	D	19.0	80.0	6/4	SOW	1.06	1.45
4SE15054L	15	575	3	1750	D	15.2	64.0	8/4	SOW	0.83	----
4SE4526HL	4.5	230	1	1150	E	22.0	95.0	10/4	SOW	0.75	1.00 -- 0.88
4SE4596HL	4.5	200-230	3	1150	C/G	16.6/14.4	51.3/64.0	10/4	SOW	0.75	1.24
4SE4546HL	4.5	460	3	1150	F	7.2	29.5	10/4	SOW	0.75	4.96
4SE4556HL	4.5	575	3	1150	F	5.7	23.6	10/4	SOW	0.75	----
4SE7596HL	7.5	200-230	3	1150	B/E	25.3/22.0	74.8/86.0	10/4	SOW	0.75	0.86
4SE7546HL	7.5	460	3	1150	E	11.0	43.0	10/4	SOW	0.75	3.44
4SE7556HL	7.5	575	3	1150	E	8.8	34.4	10/4	SOW	0.75	----
4SE7524HL	7.5	230	1	1750	A	39.0	96.0	6/4	SOW	1.06	0.5 -- 2.20
4SE7534HL	7.5	230	3	1750	D	26.8	80.0	8/4	SOW	0.83	0.71
4SE7544HL	7.5	460	3	1750	D	13.4	40.0	8/4	SOW	0.83	2.85
4SE7554HL	7.5	575	3	1750	D	10.7	32.0	10/4	SOW	0.75	----
4SE11334HL	11.3	230	3	1750	D	28.0	126.0	8/4	SOW	0.83	0.43
4SE11344HL	11.3	460	3	1750	D	14.0	63.0	8/4	SOW	0.83	1.72
4SE11354HL	11.3	575	3	1750	D	11.2	50.4	10/4	SOW	0.75	----
4SE15034HL	15	230	3	1750	D	38.0	160.0	6/4	SOW	1.06	0.35
4SE15044HL	15	460	3	1750	D	19.0	80.0	6/4	SOW	1.06	1.45
4SE15054HL	15	575	3	1750	D	15.2	64.0	10/4	SOW	0.75	----

50Hz											
4SE45Z4L	(1.9)	380-415	3	1450	E	9.1	28.0	10/4	SOW	0.75	5.71
4SE75Z4L	(3.2)	380-415	3	1450	D	13.4	40.0	10/4	SOW	0.75	2.85
4SE113Z4L	(4.8)	380-415	3	1450	D	14.0	63.0	10/4	SOW	0.75	1.72
4SE150Z4L	(6.4)	380-415	3	1450	D	19.0	80.0	8/4	SOW	0.83	1.45

Winding Resistance ± 5%, measured from terminal block. Pump rated for operation at ± 10% voltage at motor.

Optional - Moisture & Temperature sensor cord for ALL models is 18/5 SOW, 0.476 (12) ± .02 O.D.

SECTION E: PREVENTATIVE MAINTENANCE

As the motor is oil filled, no lubrication or other maintenance is required, and generally Crane Pumps & Systems will give very reliable service and can be expected to operate for years on normal sewage pumping without failing. However as with any mechanical piece of equipment a preventive maintenance program is recommended and suggested to include the following checks:

- 1) Inspect motor and seal chambers for oil level and contamination and repair as required per section F-1.
- 2) Inspect impeller and body for excessive build-up or clogging and repair as required per section F-2.
- 3) Inspect motor and bearings and replace as required per section F-3.
- 4) Inspect seal and diaphragm for wear or leakage and repair as required per section F-4.

SECTION F: SERVICE AND REPAIR

NOTE: All item numbers in () refer to Figures 10 & 11, 4SE-L & 4SEU-L Pumps; Figures 12 & 13, 4SE-HL.

F-1) Lubrication:

Anytime the pump is removed from operation the cooling oil in the motor housing (2) and seal chamber, must be checked visually for oil level and contamination.

F-1.1) Checking Oil:

Motor Housing - To check oil, set unit upright. Remove cap screws (6), lift conduit box assembly (10) from motor housing (2) but **DO NOT** disconnect conduit box wiring from motor leads. With a flashlight, visually inspect the oil in the motor housing (2) to make sure it is clean, clear and that oil level is above all internal componentry.

Seal Chamber - Place pump on its side with pipe plug (22) downward, remove pipe plug (22) and drain oil from the seal chamber. If the oil is found to contain considerable water or other contamination or little oil drains out, the shaft seal (46) and diaphragm (32) should be inspected and replaced if required.

F-1.2) Testing Oil:

1. Place pump on its side, remove cap screws (6), lift conduit box assembly (10) from motor housing (2) and drain oil into a clean, dry container. In separate container drain seal chamber by removing pipe plug (22).
2. Check oil for contamination using an oil tester with a range to 30 Kilovolts breakdown.
3. If oil is found to be clean and uncontaminated (measure above 15 KV. breakdown), refill the motor housing and seal chamber as per section F-1.3.
4. If oil is found to be dirty or contaminated (or measures below 15 KV. breakdown), the the pump must be carefully inspected for leaks at the shaft seal (46), conduit box assembly (10), diaphragm (32), O-ring (42), pipe plug (22) and pressure valve (5) before refilling with oil. To locate the leak, perform a pressure test as per section F-1.4. After leak is repaired, refill with new oil as per section F-1.3.

F-1.3) Replacing Oil:

Motor Housing - Drain all oil from motor housing and dispose of properly. Refill with (see parts list for amount) new cooling oil as per Table 1. An air space must remain in the top of the motor housing to compensate for oil expansion (see Fig. 10 or 12). Set unit upright and fill only until the motor, as viewed through the conduit box opening, is just covered and no more. Reassemble the O-ring (11), conduit box assembly (10) and cap screws (6), apply thread locking compound to each cap screw (6) thread before installing. Torque cap screws (6) to 15 ft., lb.

Seal Chamber - Refill chamber completely full with new cooling oil per Table 1 or reuse the uncontaminated oil. (See parts list for amount.)



Important! - Do not overfill oil! Overfilling of motor housing with oil can create excessive and dangerous hydraulic pressure which can destroy the pump and create a hazard. Overfilling oil voids warranty.

TABLE 1 - COOLING OIL - Dielectric	
SUPPLIER	GRADE
BP	Enerpar SE100
Conoco	Pale Paraffin 22
Mobile	D.T.E. Oil Light
G & G Oil	Circulating 22
Imperial Oil	Voltesso-35
Shell Canada	Transformer-10
Texaco	Diala-Oil-AX
Woco	Premium 100

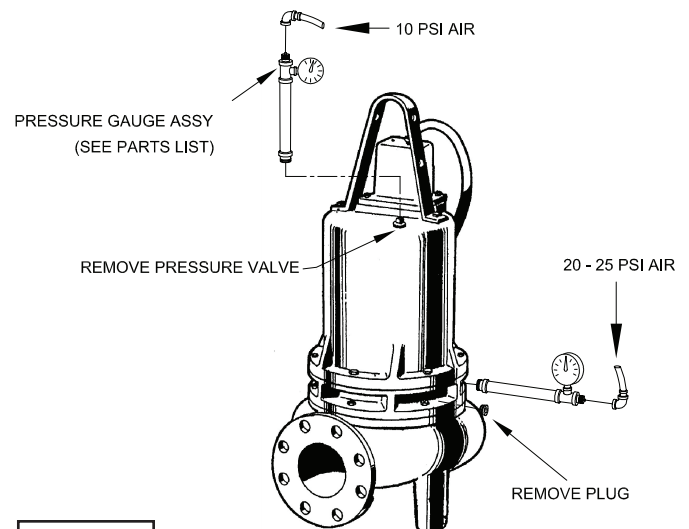

FIGURE 2



Caution! - Pressure builds up extremely fast, increase pressure by "tapping" air nozzle. Too much pressure will damage seal. Do Not exceed 10 P.S.I. in motor housing & 20-25 P.S.I. in seal chamber.

F-1.4) Pressure Test:

Motor Housing - Before checking the pump for leaks around the shaft seal, square rings, and cord inlet, the oil level should be full as described in section F-1.3. Remove pressure valve (5) from motor housing (2). Apply pipe sealant to pressure gauge assembly and tighten into pressure valve hole (See Fig. 2). Pressurize motor housing to 10 P.S.I. Use a soap solution around the sealed areas and inspect joints for “air bubbles”. If, after five minutes, the pressure is still holding constant, and no “bubbles” are observed, slowly bleed the pressure and remove the gauge assembly. Replace the Pressure valve using a sealant. If the pressure does not hold, then the leak must be located.

Seal Chamber - Remove pipe plug (22) from Bearing Bracket (21) and check that seal chamber is full of oil. Apply pipe sealant to pressure gauge assembly and tighten into hole in bearing bracket (21). Pressurize seal chamber to 20-25 PSI and check for leaks as outlined above.

F-2) Impeller and Volute Service:

F-2.1) Disassembly and Inspection:

To clean out volute (26) or replace impeller (28), or replace wear ring (31), on High-Efficiency pumps, disconnect power, remove hex nuts (20) and vertically lift motor and seal assembly from body (26). Clean out body if necessary. Clean and examine impeller (28), for pitting or wear and replace if required, inspect gasket (41) and replace if cut or damaged. If the impeller (28) requires replacing, remove cap screw (34) and washer. The impeller is keyed onto the shaft with a square key (33) and to remove, pull impeller straight off the shaft using a wheel puller, if required. If the wear ring (31) on High-Efficiency pumps require replacing, split the wear ring (31) and remove, be careful not to damage the volute. Before reinstalling, check the motor shaft and impeller bore for damage.

F-2.2) Reassembly:

To install wear ring (31) on High-Efficiency pumps, first apply retaining compound to the bore of body (26) and then press wear ring (31) into bore of body (26) until seated. To install impeller (28), on all models, apply a thin film of oil to motor shaft and slide impeller straight onto shaft, keeping keyways lined up. Drive key (33) into keyway. Locate washer, Apply thread lock primer (such as Loctite® Primer T) let set per manufactures' directions. Apply thread locking compound to cap screw (34) threads, thread cap screw (34) into shaft and torque to 35 ft. lb. Rotate impeller to check for binding. Position gasket (41) on volute flange and install impeller and motor housing over studs and onto volute (26). Apply thread locking compound to threads of each stud (24). Thread nut (20) onto stud (24) and torque to 24 ft. lb. Check for free rotation of motor and impeller.

F-3) Motor and Bearing Service

F-3.1) Disassembly and Inspection:

To examine or replace the motor (1) and bearings (3) and (47), disassemble pump, volute and impeller (as outlined in paragraph F-2.1) and disassemble seal plate and shaft seal (as outlined in paragraph F-4.1). Drain oil from motor as outlined in paragraph F-1.3.

Position unit upright, using blocks to avoid resting unit on shaft. After removal of cable and box assembly (10) from motor housing (2), remove cable lead wires from motor lead wires and moisture and temperature sensors wires (if equipped) from control cable by unscrewing connectors (12) and (17). The wiring connections should be noted to insure correct connections when reassembling. Remove cap screws (19). Vertically lift the outside motor housing (2) from bearing bracket (21) with lifting strap (7). Inspect square ring (42) for damage or cuts. Remove the upper motor bolts and lift upper end bell from motor (1). Examine upper bearing (3) and replace if required. If replacement is required, remove bearing (3) from motor shaft using a wheel puller.

NOTE SPECIAL BELLVILLE WASHERS in upper motor housing required to compensate for shaft expansion. These Bellville washers and spacer shims (9) and (29) must be properly reinstalled to give the required constant down force on the motor shaft. See Section F-3.3.

Vertically lift stator. Inspect winding for shorts and resistance. To test the temperature sensor (if equipped), check for continuity between the black and white wires. If found to be defective contact a motor service station or Crane Pumps & Systems service department. Pull motor rotor and lower bearing (47) vertically from bearing bracket (21). Examine bearing (47) and replace if required. If replacement is required, remove bearing (47) from motor shaft using a wheel puller. Check rotor for wear. If rotor or the stator windings are defective, the complete motor must be replaced. While disassembled, check moisture sensor wires (16) (if equipped), that they are secured to electrodes (18) with lockwashers (15) and screws (14).



Important !

All parts must be clean before reassembly.

F-3.2) Reassembly:

Bearings - When replacing bearings, be careful not to damage the rotor or shaft threads. (If so equipped, fill notch should face the rotor core for both upper and lower bearings). Clean the shaft thoroughly. Apply adhesive compound to the shaft and press bearing (47) on the motor shaft, position squarely onto the shaft applying force to the inner race of the bearing only, until bearing seats against shoulder of the shaft. Reassemble top bearing (3) in the same manner.

Motor - Slide lower bearing (47) and motor rotor squarely into the bearing bracket (21) until bearing seats on the bottom. Position motor housing and stator into pilot, install bellville washers and shims (9) and (29) in upper end bell. Position upper motor end bell aligning holes and thread cap screws into bearing bracket (21). Torque to 16 ft. lb.. Place all motor leads above the motor. Position square ring (42) over bearing bracket (21) and lower housing (2) over motor and into pilot, being sure to orient motor housing handle parallel to motor end bell reliefs. Apply thread locking compound to cap screws (19) threads and install. Torque to 24 ft. lb.

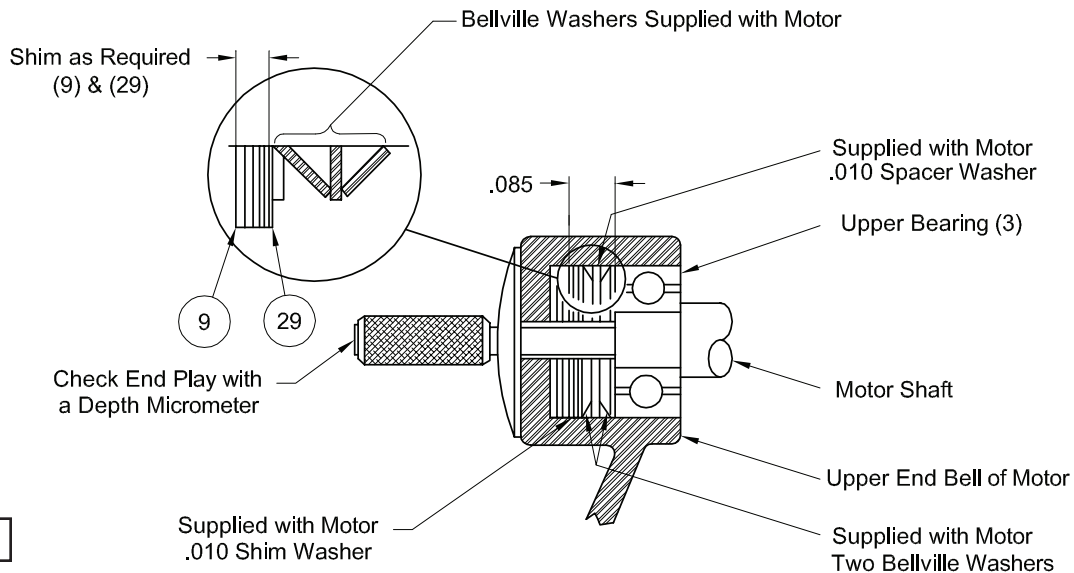

FIGURE 3

F-3.3) Checking Of End-Play:

Measure distance with micrometer from the top surface of the motor cover to the end of the shaft. See Figure 3. Temporarily set the partially assembled unit on the lower end of the shaft, causing the bearings to slide up in the bearing retainer. When the bearings bottom securely, again measure the distance from the top surface of the motor cover to the end of the shaft. This difference should be between .015 to .030 inches. If the end-play is within these tolerances, proceed with reassembly. If the end-play is not within the above listed tolerances, the motor upper end bell must be disassembled and sufficient .010 shims (9) must be added or removed as required. Reassemble and recheck again for the required listed end-play tolerance.

F-4.1) Disassembly and Inspection:

Diaphragm - To examine or replace the diaphragm (32) or shaft seal (46), remove impeller (28) as outlined in paragraph F-2.1. Drain oil from seal chamber as outlined in paragraph F-1.3. Remove cap screws (8) and lifting strap (7). Set unit upside down on blocks to avoid damaging cords. Remove socket head cap screws (39) and lift seal plate (25) vertically, being cautious to avoid seal damage, together with diaphragm (32), clamp (43) and outboard stationary member (46A) of shaft seal (46), from bearing bracket (21). Examine diaphragm (32), if it is ruptured, cracked or damaged, replace by removing screws (44) and diaphragm clamp (43). Also, clean out vent holes in seal plate (25). Check moisture sensor probes (18) (if equipped) for damage. Replace by disconnecting wires (16) by removing screws (14) and lockwashers (15). Then remove probe (18) from bearing bracket (21).

F-4) Shaft Seal and Diaphragm Service:



Important! - Handle seal parts with extreme care. do not scratch or mar lapped surfaces.

Seal - To expose shaft seal (46) for examination, complete above procedure and slide off outboard rotating member (46B), See Figure 4. Remove inboard rotating member (46), from shaft. Examine all seal parts and especially contact faces. Inspect seal for signs of wear such as uneven wear pattern on stationary members, chips and scratches on either seal face. **DO NOT** interchange seal components, replace the entire shaft seal (46).

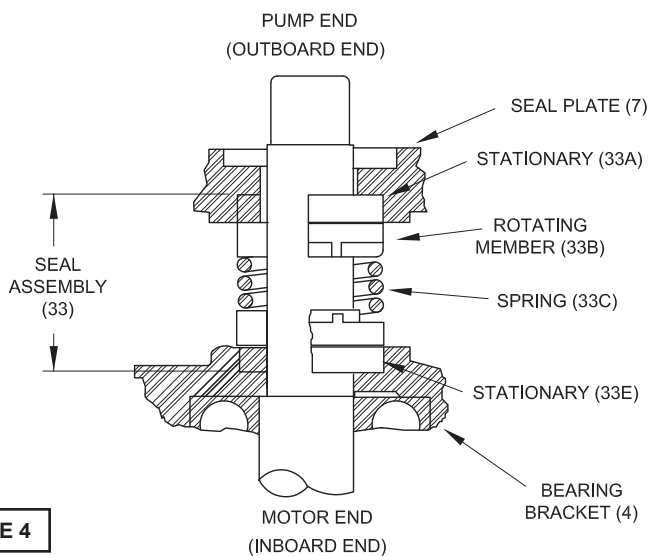

FIGURE 4

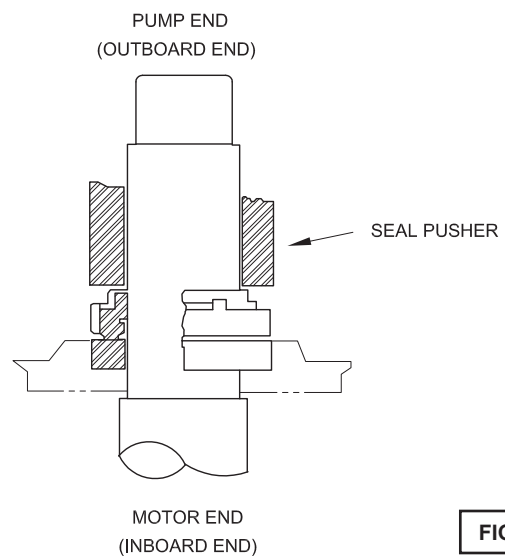

FIGURE 5

F-4.2) Reassembly:

Diaphragm - At reassembly, make sure the bulge and molded-in part number of diaphragm (32) is facing the seal plate (25). With diaphragm (32) in place, lay diaphragm clamp (43) in place on seal plate (25) and insert the four cap screws (44) and tighten. Apply pipe thread compound to moisture sensor probe (18), if equipped, and insert in bearing bracket (21). Attach wires (16) with lockwashers (15) and screws (14).

Seal - Clean and oil seal cavities in bearing bracket (21) and seal plate (25). Lightly oil (**DO NOT use grease**) outer surface of inboard stationary member (46E) and outboard stationary member (46A). Press inboard stationary member (46E) firmly into bearing bracket (21) and outboard stationary (46A) into seal plate (25), using a seal pusher (see parts list-seal tool kit), nothing but the seal pusher is to come in contact with seal face (See Figures 5 & 6).

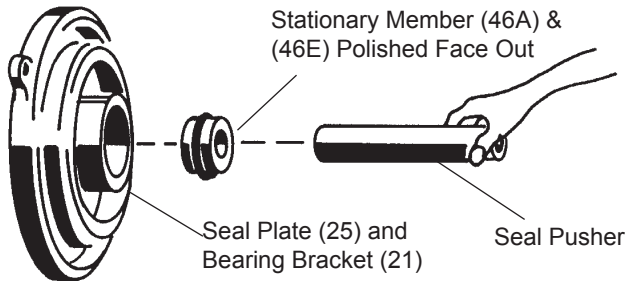

FIGURE 6

Important ! - DO NOT hammer on the seal pusher- it will damage the seal face.

Make sure the stationary members are in straight and that the rubber ring is not out of its groove. Lightly oil (**DO NOT use grease**) shaft and inner surface of bellows on rotating member (46D) See Figure 7. With lapped surface facing bearing bracket (21), slide rotating member (46D) onto shaft, using seal pusher, until lapped faces of (46D) and (46E) are together (See Figure 6). It is extremely important to keep seal faces clean during assembly. Dirt particles lodged between these faces will cause the seal to leak.

Make sure driving lugs in retainer are matched in rotating member. Place spring (46C) over shaft and in place on rotating member (46E), making sure it is seated in retainer and not cocked or resting on bellows tail. Re-oil shaft and lightly oil inner surface of outboard rotating member (46B).

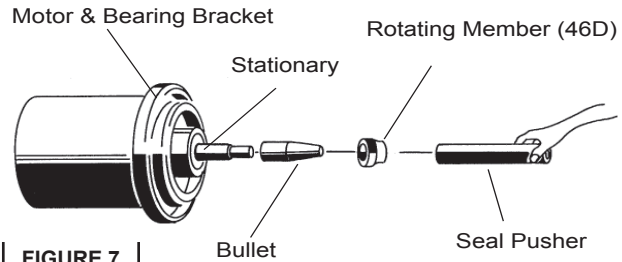

FIGURE 7

With tail section toward bearing bracket (21), slide rotating member (46B) onto shaft with seal pusher until retainer engages spring (46C) and spring is compressed slightly. Make sure spring (46C) is properly engaged in both retainers. Slide seal plate (25) over shaft onto bearing bracket (21), being careful not to damage outboard stationary member (46A) and align holes for socket head cap screws (39). Thread socket head cap screws (39) into bearing bracket (21) and tighten. Fill seal chamber with oil as outlined in paragraph F-1.3. Reassemble impeller and volute per paragraph F-2.2.

F-4.3) Wiring Connections:

Check power cable (10A) and control cable (10D) (if used), on conduit box (10), for cracks or damage and replace complete conduit box assembly (10) if required (see Fig. 5). Bring motor wires through wire opening in top of housing (2), check sleeving (53) and replace if required, position square ring (11) in conduit housing (10) and reconnect motor leads to power cable and moisture and temperature sensor leads to control cable (if equipped) using connectors (12), (17) and insulators (54) as show in Figure 8.

F-4.4) Conduit Box and Cable Assembly:

Refill with cooling oil as outlined in paragraph F-1.3. Position conduit box (10) and square ring (11) over opening, apply thread locking compound to cap screws (6) threads and torque to 16 ft. lb. Remove gland nuts (10B) and (10F), friction rings (10C) and (10G), and grommets (10D) and (10H) from conduit box (10) inspect and replace if required. (See Figure 9). Insert one friction ring (10C), grommet (10D), one friction ring (10C) and gland nut (10B) into conduit box for power cable (10A). For control cable (10E) (if used), insert grommet (10H), friction ring (10G) and gland nut (10F). Torque gland nuts (10B) and (10F) to 15 ft. lb. to prevent water leakage.

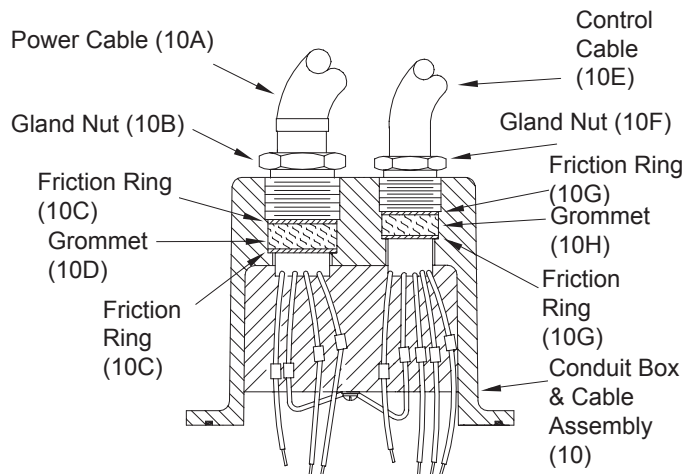
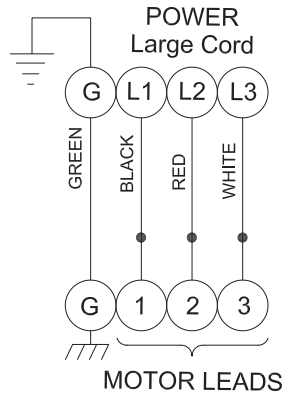
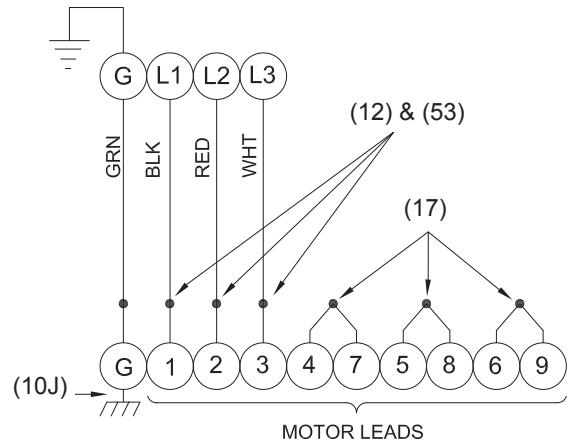

FIGURE 9

SINGLE PHASE 240 VOLT AC	
Power Cable	Motor Lead Number
Green (Ground)	Green
Black	1
Red	2
White	3



THREE PHASE 480-600 VOLT AC	
Power Cable	Motor Lead Number
Green (Ground)	Green
Black	1
Red	2
White	3
	4 & 7 Together
	5 & 8 Together
	6 & 9 Together



THREE PHASE 200-240 VOLT AC	
Power Cable	Motor Lead Number
Green (Ground)	Green
Black	1 & 7
Red	2 & 8
White	3 & 9
	4, 5 & 6 Together

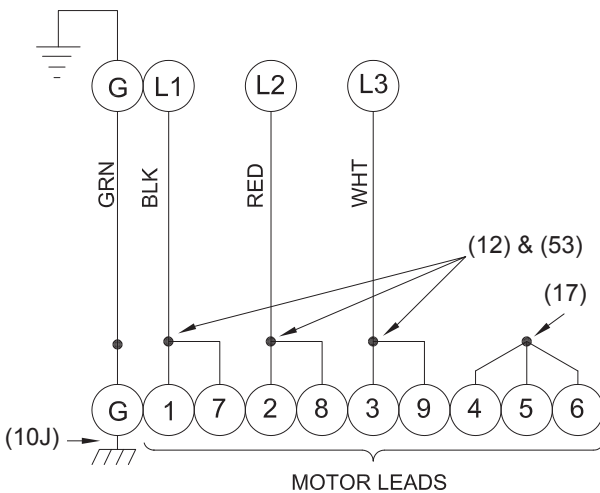

MOISTURE AND TEMPERATURE SENSORS	
Control Cable	Lead Number
Green (Ground)	Green
Black	T1 (Temperature Sensor)
White	T2 (Temperature Sensor)
Red	W1 (Moisture Sensor)
Orange	W2 (Moisture Sensor)

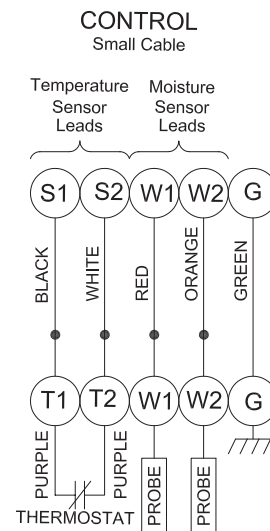

FIGURE 8

SECTION: G REPLACEMENT PARTS

G-1 ORDERING REPLACEMENT PARTS:

When ordering replacement parts, ALWAYS furnish the following information:

1. Pump serial number and date code. (Paragraph G-4)
2. Pump model number. (Paragraph G-3)
3. Pump part number. (Paragraph G-2)
4. Part description.
5. Item part number.
6. Quantity required.
7. Shipping instructions.

HP.	Volts	Code	Ph.	Hz.
RPM	FLA	Model No.	2	
Part No.	3	Serial No.	1	
Impeller Dia.	Max. Liq. Temp. °C	Ins. Class		

CRANE PUMPS & SYSTEMS
105500

WARNING TO REDUCE RISK OF ELECTRICAL SHOCK DISCONNECT THE PUMP FROM THE POWER SOURCE BEFORE HANDLING OR SERVICING. SEE INSTRUCTION MANUAL FOR PROPER INSTALLATION. SEE WARNING PLATE FOR ADDITIONAL CAUTIONS.

8. Billing Instructions.

G-2 PART NUMBER:

The part number consists of a six (6) digit number, which appears in the catalog. A one or two letter suffix may follow this number to designate the design configuration. This number is used for ordering and obtaining information.

G-3 MODEL NUMBER:

This designation consists of numbers and letters which represent the discharge size, series, horsepower, motor phase and voltage, speed and pump design. This number is used for ordering and obtaining information.

G-4 SERIAL NUMBER:

The serial number block will consist of a six digit number, which is specific to each pump and may be preceded by a alpha character, which indicates the plant location. This number will also be suffixed with a four digit number, which indicates the date the unit was built (Date Code). **EXAMPLE: A012345 0490.**

Reference the six digit portion (Serial Number) of this number when referring to the product.

TROUBLE SHOOTING

CAUTION ! Always disconnect the pump from the electrical power source before handling.
 If the system fails to operate properly, carefully read instructions and perform maintenance recommendations.
 If operating problems persist, the following chart may be of assistance in identifying and correcting them:
MATCH “CAUSE” NUMBER WITH CORRELATING “CORRECTION” NUMBER.

NOTE: Not all problems and corrections will apply to each pump model.

PROBLEM	CAUSE	CORRECTION
Pump will not run	1. Poor electrical connection, blown fuse, tripped breaker or other interruption of power, improper power supply. 2. Motor or switch inoperative (to isolate cause, go to manual operation of pump). 2a. Float movement restricted. 2b. Switch will not activate pump or is defective. 2c. Defective motor 3. Insufficient liquid level.	1. Check all electrical connections for security. Have electrician measure current in motor leads, if current is within $\pm 20\%$ of locked rotor Amps, impeller is probably locked. If current is 0, overload may be tripped. Remove power, allow pump to cool, then recheck current. 2a. Reposition pump or clean basin as required to provide adequate clearance for float.
Pump will not turn off	2a. Float movement restricted. 2b. Switch will not activate pump or is defective. 4. Excessive inflow or pump not properly sized for application. 9. Pump may be airlocked 14. H-O-A switch on panel is in “HAND” position	2b. Disconnect level control. Set ohmmeter for a low range, such as 100 ohms full scale and connect to level control leads. Actuate level control manually and check to see that ohmmeter shows zero ohms for closed switch and full scale for open switch. (Float Switch). 2c. Check winding insulation (Megger Test) and winding resistance. If check is outside of range, dry and recheck. If still defective, replace per service instructions.
Pump hums but does not run	1. Incorrect voltage 8. Impeller jammed or loose on shaft, worn or damaged, impeller cavity or inlet plugged.	2c. Check winding insulation (Megger Test) and winding resistance. If check is outside of range, dry and recheck. If still defective, replace per service instructions.
Pump delivers insufficient capacity	1. Incorrect voltage. 4. Excessive inflow or pump not properly sized for application. 5. Discharge restricted. 6. Check valve stuck closed or installed backwards. 7. Shut-off valve closed. 8. Impeller jammed or loose on shaft, worn or damaged, impeller cavity or inlet plugged. 9. Pump may be airlocked. 10. Pump running backwards	3. Make sure liquid level is at least equal to suggested turn-on point. 4. Recheck all sizing calculations to determine proper pump size. 5. Check discharge line for restrictions, including ice if line passes through or into cold areas. 6. Remove and examine check valve for proper installation and freedom of operation. 7. Open valve.
Pump cycles too frequently or runs periodically when fixtures are not in use	6. Check valve stuck closed or installed backwards. 11. Fixtures are leaking. 15. Ground water entering basin.	8. Check impeller for freedom of operation, security and condition. Clean impeller and inlet of any obstruction. 9. Loosen union slightly to allow trapped air to escape. Verify that turn-off level of switch is set so that the suction is always flooded. Clean vent hole.
Pump shuts off and turns on independent of switch, (trips thermal overload protector). CAUTION! Pump may start unexpectedly. Disconnect power supply.	1. Incorrect voltage. 4. Excessive inflow or pump not properly sized for application. 8. Impeller jammed, loose on shaft, worn or damaged, impeller cavity or inlet plugged. 12. Excessive water temperature. (internal protection only)	10. Check rotation. If power supply is three phase, reverse any two of three power supply leads to ensure proper impeller rotation.. 11. Repair fixtures as required to eliminate leakage.
Pump operates noisily or vibrates excessively	2c. Worn bearings, motor shaft bent. 5. Debris in impeller cavity or broken impeller 10. Pump running backwards 13. Piping attachments to building structure too rigid or too loose.	12. Check pump temperature limits & fluid temperature. 13. Replace portion of discharge pipe with flexible connector. 14. Turn to automatic position. 15. Check for leaks around basin inlet and outlets.

4SE & 4SEU Pump Series

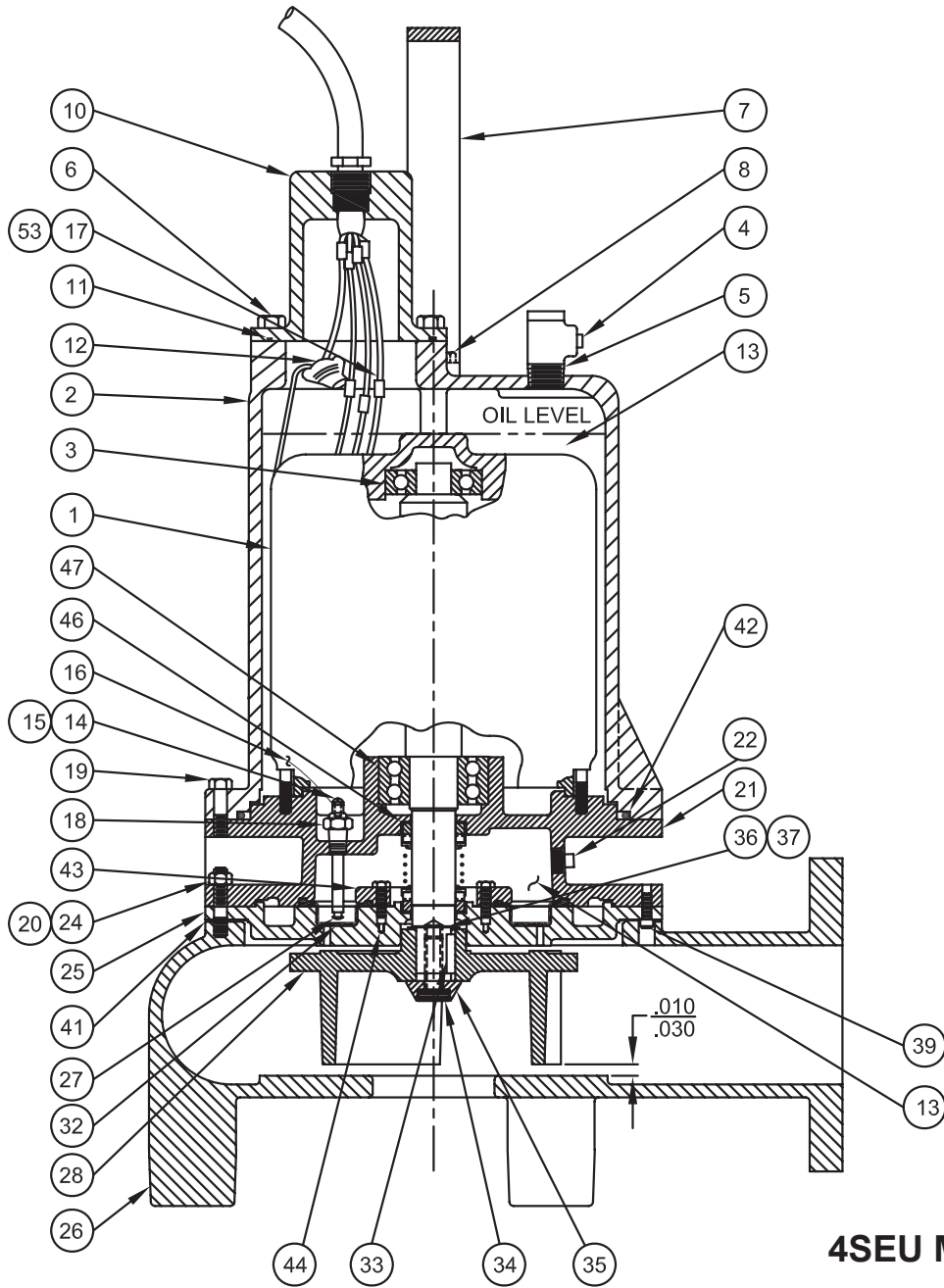

4SEU Models ONLY

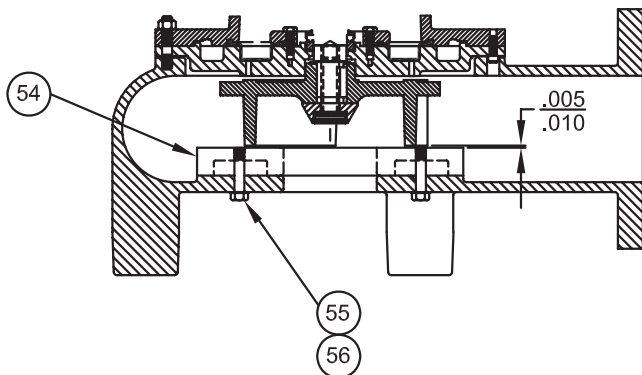
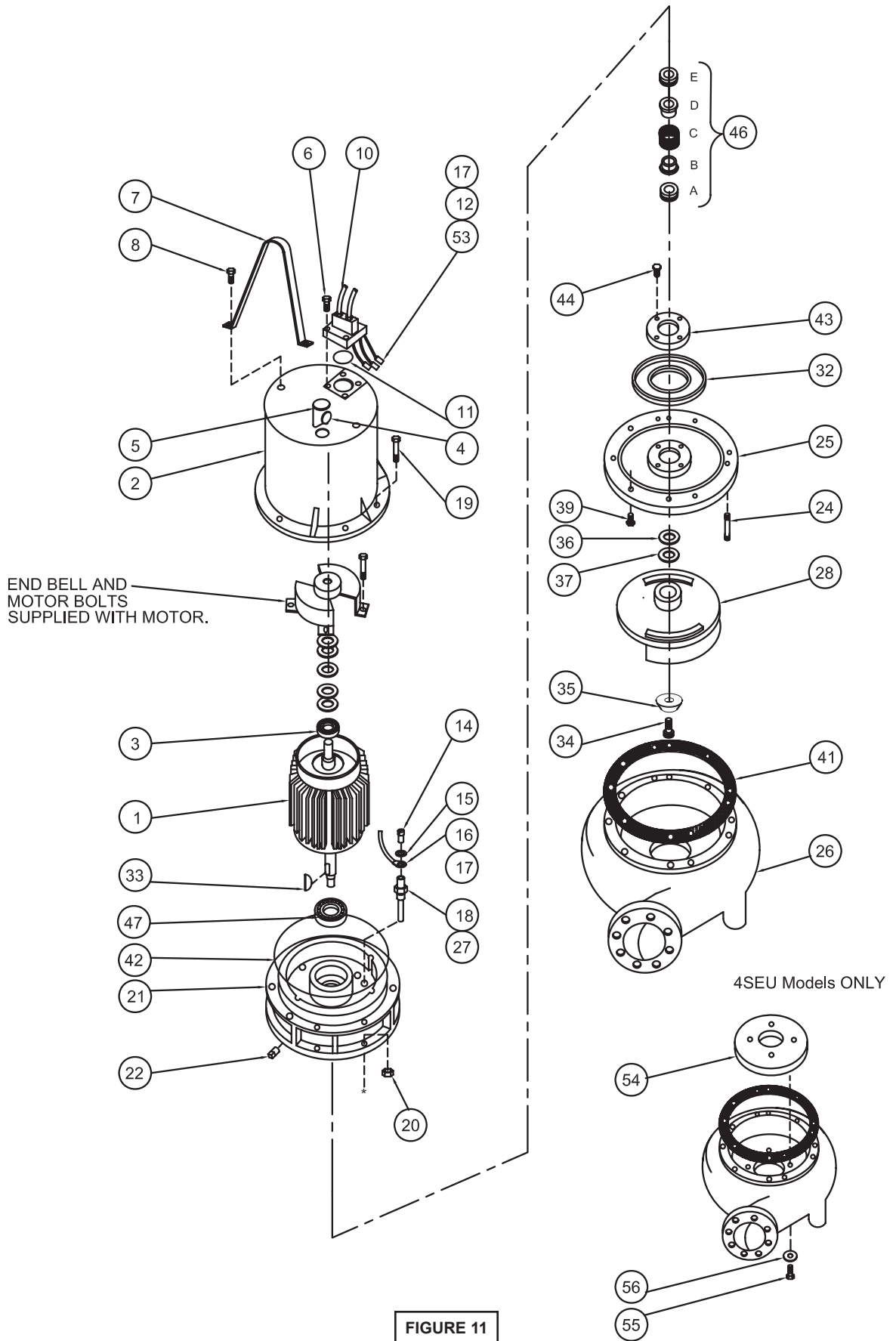

FIGURE 10

4SE & 4SEU Pump Series



4SE & 4SEU Pump Series

PARTS KITS

- Seal Repair Kit.....P/N-130179** (+) 11, 32, 33, 34, 35, 41, 42, 46
Overhaul Kit.....P/N-130175 (◆) 3, 11, 12, 16, 17, 32, 33, 34, 35, 36, 37, 41, 42, 46, 47, 53
Seal Tool Kit.....P/N-085737
Pressure Gauge Kit...P/N-085343

PARTS LIST - Standard

ITEM	QTY	PART NO.	DESCRIPTION
1	1	072688	Motor- 4SE4526L
		072689	4SE4596L, 46L
		092867	4SE4556L
		072690	4SE7596L, 46L
		092868	4SE7556L
		072691	4SE11396L, 46L
		092869	4SE11356L
		072692	4SE4524L
		072695	4SE4564L
		072693	4SE4534L, 44L
		092870	4SE4554L
		072694	4SE7524L
		072696	4SE7564L
		072695	4SE7534L, 44L
		092816	4SE7554L
		072697	4SE11364L
		072697	4SE11334L, 44L
		092817	4SE11354L
		072697	4SE15034L, 44L
		092818	4SE15054L
		072697	4SEU15034L, 44L
		072697F	4SEU15054L
		088795	4SEU15032L, 42L
		088797	4SEU15052L
2	1	053030	Motor Housing
3	1	039734	Ball Bearing
4	1	070624	Pipe Closure
5	1	070623	Pressure Relief Valve
6	4	1-34-1	Cap Screw, 3/8-16 x 1" Ig Stainless
7	1	036863A	S.S. Lifting Strap
8	2	1-68-1	Cap Screw, 1/2-13 x 1-1/4" Ig Stainless
10	1	See Table 2	Conduit Box & Cable Assembly
10a	1	-----	Power Cable (Not Sold Separately)
10b	1	051447	* Gland Nut
	1	072559	* Gland Nut, (For 7.5 & 11.3Hp 3Ph & 15Hp 575V)
	1	052259	* Gland Nut (For 7.5HP, 1PH & 15HP ONLY)
10c	2	051450	* Friction Ring
	2	071431A	* Friction Ring (For 7.5 & 11.3Hp 3Ph & 15Hp 575V)
	2	110929	* Friction Ring (For 7.5HP, 1PH & 15HP ONLY)
10d	1	051452	* Grommet
	1	071430A	* Grommet (For 7.5 & 11.3Hp 3Ph & 15Hp 575V)
	1	110928	* Grommet (For 7.5HP, 1PH & 15HP ONLY)
10e	1	-----	* Control Cable (Not Sold Separately)
10f	1	051448	* Gland Nut
10g	2	021531	* Friction Ring
10h	1	066871	* Grommet
10J	1	030169	* Ground Screw 10-32 x 5/8 Lg Stainless
11	1	051937	+◆ Square Ring
12	5	016406	◆ Connector
	5	030148	◆ Connector (7.5HP, 1PH & 15HP ONLY)
13	2.5 Gal	029034	Oil - Motor Housing
	35 oz.		Oil - Seal Cavity
14	2		Machine Screw 6-32 x 1/4 Cad. Plt. Steel 5-32-6
15	2	052563	Lockwasher No. 6 Steel

(*) Included with item number 10.

4SE & 4SEU Pump Series

16	2	051487	◆	Moisture Sensor Wire	
17	4	052990	◆	Connector	(Sensor Wires)
18	2	039383		Electrode	
19	6	1-38-1		Hex Hd Screw	3/8-16 x 1.50" lg Stainless
20	6	15-23-1		Nut	3/8-16 Stainless
21	1	039030		Bearing Bracket	
22	1	003202		Pipe Plug	
24	6	033824		Stud	3/8-16 x 2" lg Stainless
25	1	039038		Seal Plate	
26	1	066292		Volute	4SE Models
		069753C		Volute	4SEU Models
		085014		Volute (Optional)	With Strainer
27	2	039934		Caplug	
28	1	1150RPM		Impeller, Cast Iron	4SE, Models
		084895TB	1750RPM	11.3HP, 1150RPM	10.50" Dia.
		084895TC			10.38" Dia.
		084895TD			10.25" Dia.
		084895TE			10.12" Dia.
		084895TF		7.5HP, 1150RPM	10.00" Dia.
		084894TG			9.88" Dia.
		084894TH			9.75" Dia.
		084894TJ			9.62" Dia.
		084894TK			9.50" Dia.
		084894TL			9.38" Dia.
		084894TM			9.25" Dia.
		084894TN			9.12" Dia.
		084894TP			9.00" Dia.
		084894TQ			8.88" Dia.
		084894TR		4.5HP, 1150RPM	8.75" Dia.
		084894TS			8.62" Dia.
		084894TT		15HP, 1750RPM	8.50" Dia.
		084894TU			8.38" Dia.
		084894TV			8.25" Dia.
		084894TW			8.12" Dia.
		084894TX		11.3HP, 1750RPM	8.00" Dia.
		084894TY			7.88" Dia.
		084894TZ			7.75" Dia.
		084894UA			7.62" Dia.
		084894UB			7.50" Dia.
		084894UC			7.38" Dia.
		084894UD			7.25" Dia.
		084894UE			7.12" Dia.
		084894UF		7.5HP, 1750RPM	7.00" Dia.
		084894UG			6.88" Dia.
		084894UH			6.75" Dia.
				084895UJ	6.62" Dia.
				084895UK	4.5HP, 1750RPM 6.50" Dia.
				084895UL	6.38" Dia.
				084895UM	6.25" Dia.
				084895UN	6.12" Dia.
				084895UP	6.00" Dia.
				084895UQ	5.88" Dia.
				084895UR	5.75" Dia.
				084895US	5.62" Dia.
				084895UT	5.50" Dia.
				084895UU	5.38" Dia.
				084895UV	5.25" Dia.
				084895UW	5.12" Dia.
				084895UX	5.00" Dia.
28	1	052762		Impeller, Cast Iron, 4SEU, 1750RPM Models ONLY	- 10.87" Dia.
28	1	088794		Impeller, Cast Iron, 4SEU, 3450RPM Models ONLY	- 6.50" Dia.
32	1	022873	+◆	Diaphragm	
33	1	Q21-56-J8	+◆	Shaft Key	1/4 Sq. x 1.00" lg. Stainless
34	1	11-81-1	+	SKHD Screw	1/2-13 x 1-1/4 lg 18-8 stainless
35	1	4587-SS	+◆	Impeller Washer, .531 x 1.562	Stainless

4SE & 4SEU Pump Series

36	2	001348	◆	Shim .031" x 1.5" O.D.	(Impeller)
37	2	001349	◆	Shim .010" x 1.5" O.D.	(Impeller)
39	2	036803		Soc. Hd. Cap Screw	1/4-20 x 3/4" lg Stainless
41	1	036852	+◆	Gasket	
42	1	056668	+◆	Square-Ring	
43	1	022879		Diaphragm Clamp Ring	
44	4	002203		Cap Screw	1/4-20 x 7/8" lg Steel
46	1	039485	+◆	Shaft Seal (Both Ends)	Carbon/Ceramic/Buna-N (STD)
		060817		(Pump End)	Tungsten/Carbide/Buna-N
		060817SC		(Both Ends)	Tungsten/Carbide/Buna-N
47	1	039332	◆	Ball Bearing	
53	5	016405	◆	Insulator	
	5	030149	◆	Insulator	(7.5HP, 1PH & 15HP ONLY)
54	1	052761		Wear Plate	4SEU's ONLY
55	4	1-130-1		Cap Screw	5/16-18 x 1.0" lg, Stainless
56	4	20-2-1		Lockwasher	5/16 Stainless

TABLE 2 - CORD SETS

MODELS/ LENGTHS	ITEM #10 Moist. & Temp (STD) Except; 7.5Hp, 1Ph & 3Ph, 230 & 460 V, 1750RPM 11.3 & 15Hp, 3Ph, 230 & 460V, 1750RPM	ITEM #10 Moist. & Temp (STD) For; 7.5Hp, 1Ph, 1750RPM 15Hp, 3Ph, 1750RPM 15Hp, 3Ph, 230 & 460V, 3450RPM ONLY	ITEM #10 Moist. & Temp (STD) For; 7.5 & 11.3Hp, 3Ph, 230 & 460V. and 15Hp, 575V ONLY
40 Ft. (STD)	072448XE	111160XE	072700XE
50 Ft.	072448XF	111160XF	072700XF
75 Ft.	072448XJ	111160XJ	072700XJ
100 Ft.	072448XL	111160XL	072700XL
150 Ft.	072448XS	111160XS	072700XS

4SE-HL (High Efficiency) Pump Series

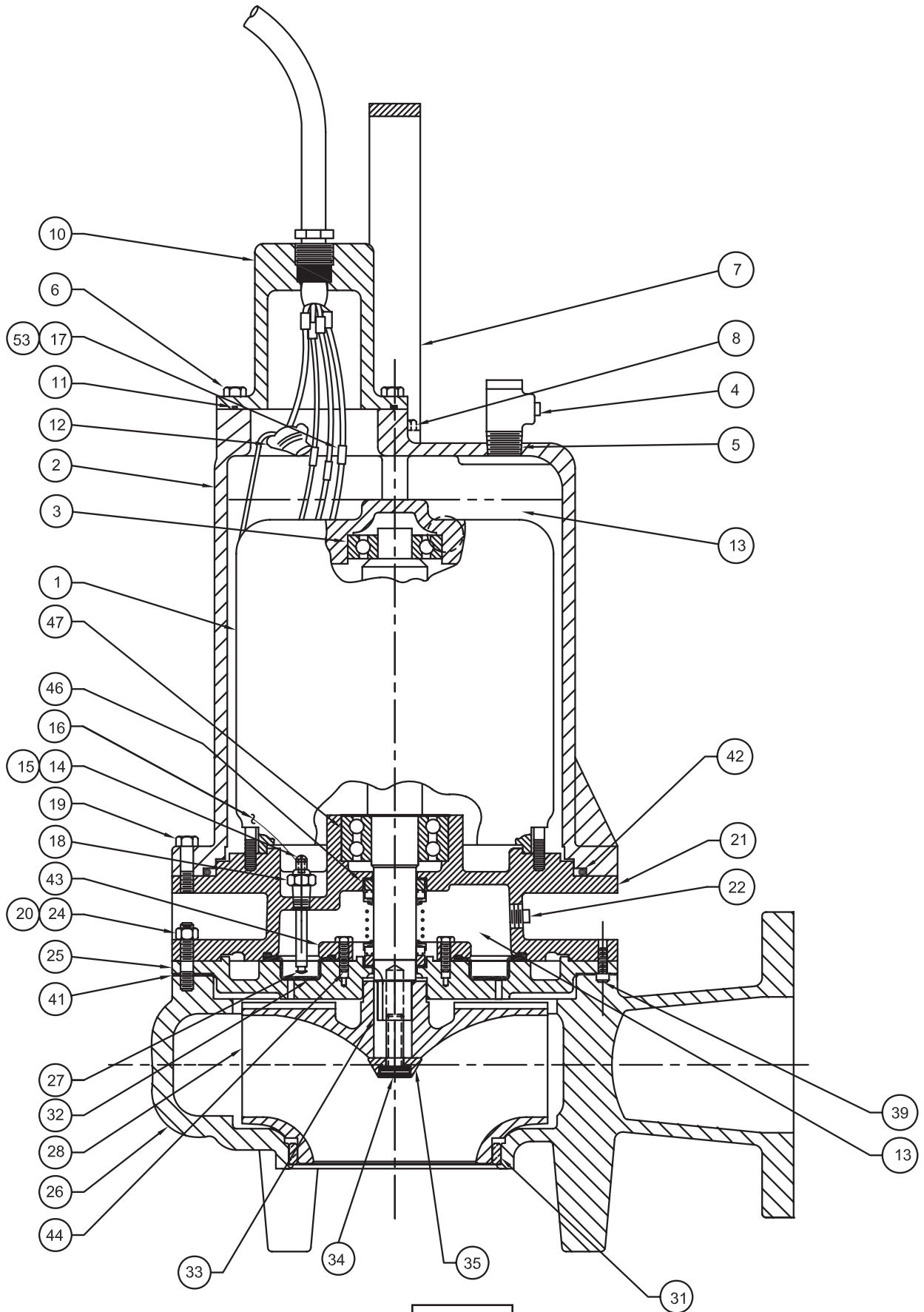
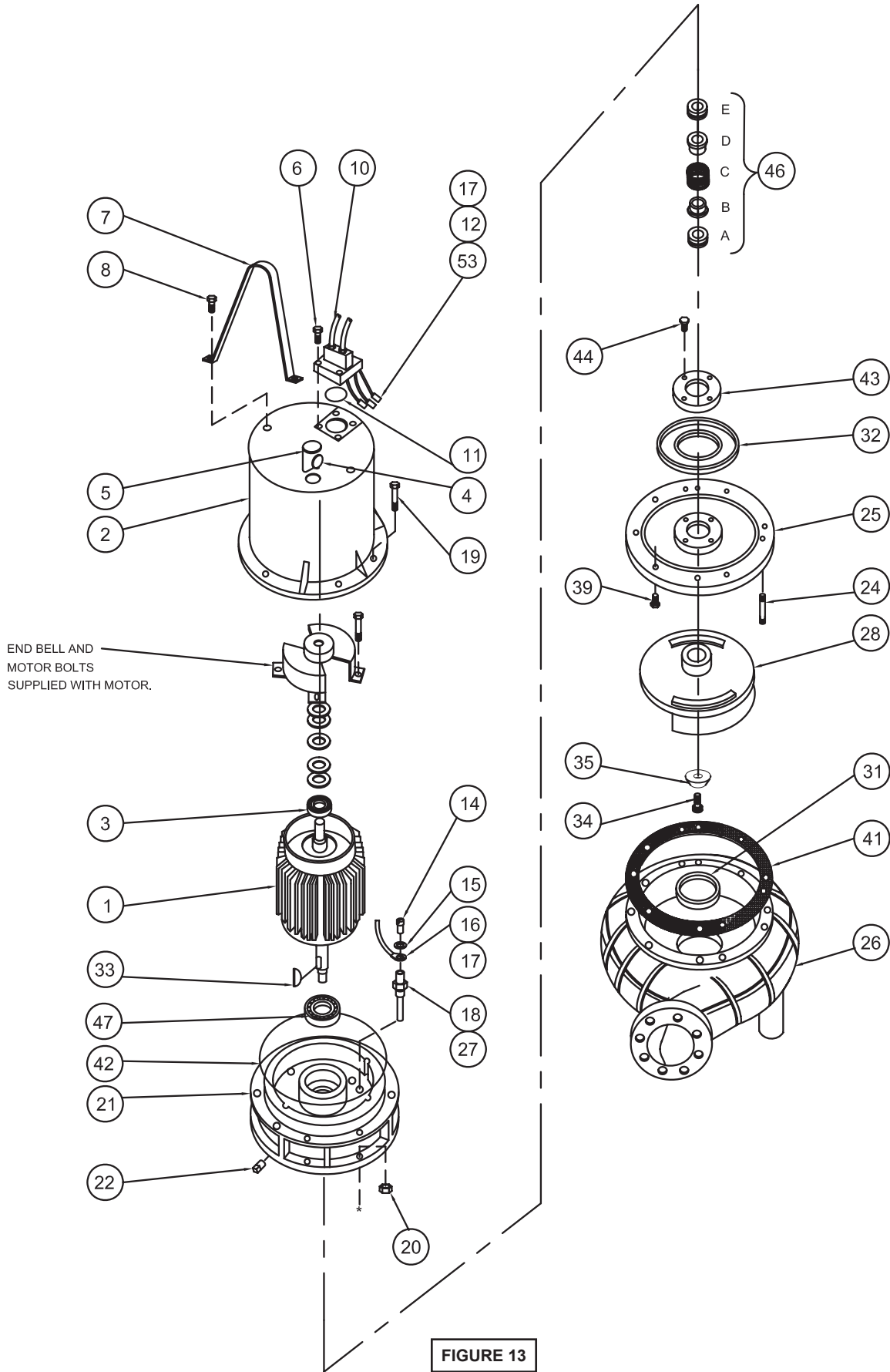

FIGURE 12

4SE-HL (High Efficiency) Pump Series



4SE-HL (High Efficiency) Pump Series

PARTS KITS

Seal Repair Kit.....P/N-130179 (+) 11, 32, 33, 34, 35, 41, 42, 46

Overhaul Kit.....P/N-130175 (♦) 3, 11, 12, 16, 17, 32, 33, 34, 41, 42, 46, 47, 54

Seal Tool Kit.....P/N-085737

Pressure Gauge Kit...P/N-085343

PARTS LIST - Standard

ITEM	QTY	PART NO.	DESCRIPTION
1	1	072688MA	Motor - 4SE4526HL
		072689MA	4SE4596HL, 46HL
		092819	4SE4556HL
		072690MA	4SE7596HL, 46HL
		092820	4SE7556HL
		072694MA	4SE7524HL
		072695MA	4SE7534HL, 44HL
		091726	4SE7554HL
		072696MA	4SE11334HL, 44HL
		091743	4SE11354HL
		072697MA	4SE15034HL, 44HL
		091744	4SE15054HL
2	1	053030	Motor Housing
3	1	039734	♦ Ball Bearing
4	1	070624	Pipe Closure
5	1	070623	Pressure Relief Valve
6	4	1-34-1	Cap Screw, 3/8-16 x 1" Ig Stainless
7	1	036863A	S.S. Lifting Strap
8	2	1-68-1	Cap Screw, 1/2-13 x 1-1/4" Ig Stainless
10	1	See Table 2	Conduit Box & Cable Assembly
10a	1	----	Power Cable (Not Sold Separately)
10b	1	051447	* Gland Nut
	1	072559	* Gland Nut, (For 7.5 & 11.3Hp 3Ph & 15Hp 575V)
	1	052259	* Gland Nut, (For 7.5HP, 1PH & 15HP ONLY)
10c	2	051450	* Friction Ring
	2	071431A	* Friction Ring, (For 7.5 & 11.3Hp 3Ph & 15Hp 575V)
	2	110929	* Friction Ring, (For 7.5HP, 1PH & 15HP ONLY)
10d	1	051452	* Grommet
	1	071430A	* Grommet, (For 7.5 & 11.3Hp 3Ph & 15Hp 575V)
	1	110928	* Grommet, (For 7.5HP, 1PH & 15HP ONLY)
10e	1	----	* Control Cable (Not Sold Separately)
10f	1	051448	* Gland Nut
10g	2	021531	* Friction Ring
10h	1	066871	*♦ Grommet
10J	1	030169	* Ground Screw 10-32 x 5/8 Lg Stainless
11	1	051937	+♦ Square Ring
12	5	016406	♦ Connector
	5	030148	♦ Connector (7.5HP, 1PH & 15HP ONLY)
13	2.5 Gal	029034	Oil - Motor Housing
	35 oz.		Oil - Seal Cavity
14	2	5-32-6	Machine Screw 6-32 x 1/4 Cad. Plt. Steel
15	2	052563	Lockwasher No. 6 Steel
16	2	051487	♦ Moisture Sensor Wire
17	4	052990	♦ Connector (Sensor Wires)
18	2	039383	Electrode
19	6	1-38-1	Hex Hd Screw 3/8-16 x 1.50" Ig Stainless
20	6	018927	Nut 3/8-16 Stainless
21	1	039030	Bearing Bracket
22	1	003202	Pipe Plug
24	6	033824	Stud 3/8-16 x 2" Ig Stainless
25	1	039038	Seal Plate
26	1	082213	Volute
27	2	039934	Caplug
28	1	082217	9.00" Dia. - 7.5, 1150 & 15, 1750

4SE-HL (High Efficiency) Pump Series

082217TA	8.88" Dia.
082217TB	8.75" Dia.
082217TC	8.62" Dia.
082217TD	8.50" Dia.
082217TE	8.38" Dia.
082217TF	8.25" Dia.
082217TG	8.12" Dia.
082217TH	8.00" Dia. - 11.3HP,1750RPM
082217TJ	7.75" Dia.
082217TL	7.62" Dia.
082217TM	7.50" Dia. - 4.5HP,1150RPM
082217TN	7.38" Dia.
082217TP	7.25" Dia.
082217TQ	7.12" Dia.
082217TR	7.00" Dia. - 7.5HP,1750RPM
082217TS	6.88" Dia.
082217TT	6.75" Dia.
082217TU	6.62" Dia.
082217TV	6.50" Dia.

31	1	082083	Wear Ring
32	1	022873	+◆ Diaphragm
33	1	Q21-56-J8	◆ Shaft Key 1/4 Sq. x 1.00" lg. Stainless
	1	Q21-39-J8	◆ Shaft Key 1/4 Sq. x 1-5/8" lg. Stainless
34	1	11-81-1	◆ SKHD Screw 1/2-13 x 1-1/4 lg 18-8 Stainless
35	1	4587-SS	Impeller Washer, .531 x 1.562 Stainless
39	2	036803	Soc. Hd. Cap Screw 1/4-20 x 3/4" lg Stainless
41	1	036852	+◆ Gasket
42	1	056668	+◆ Square-Ring
43	1	022879	Diaphragm Clamp Ring
44	4	002203	Cap Screw 1/4-20 x 7/8" lg Steel
46	1	039485	+◆ Shaft Seal (Both Ends) Carbon/Ceramic/Buna-N (STD)
		060817	(Pump End) Tungsten/Carbide/Buna-N
		060817SC	(Both Ends) Tungsten/Carbide/Buna-N
47	1	039332	◆ Ball Bearing
54	5	016405	◆ Insulator
	5	030149	◆ Insulator (7.5HP, 1PH & 15HP ONLY)

TABLE 2 - CORD SETS

MODELS/ LENGTHS	ITEM #10 Moist. & Temp (STD) Except; 7.5Hp, 1Ph & 3Ph, 230 & 460 V, 1750RPM 11.3 & 15Hp, 3Ph, 230 & 460V, 1750RPM	ITEM #10 Moist. & Temp (STD) For; 7.5Hp, 1Ph, 1750RPM 15Hp, 3Ph, 1750RPM 15Hp, 3Ph, 230 & 460V, 3450RPM ONLY	ITEM #10 Moist. & Temp (STD) For; 7.5 & 11.3Hp, 3Ph, 230 & 460V. and 15Hp, 575V ONLY
40 Ft. (STD)	072448XE	111160XE	072700XE
50 Ft.	072448XF	111160XF	072700XF
75 Ft.	072448XJ	111160XJ	072700XJ
100 Ft.	072448XL	111160XL	072700XL
150 Ft.	072448XS	111160XS	072700XS

BARNES®

BARNES®
PRESSURE PS SYSTEMS



burks®

WEINMAN®

DEMING®

PROSSER®

Limited 24 Month Warranty

Crane Pumps & Systems warrants that products of our manufacture will be free of defects in material and workmanship under normal use and service for twenty-four (24) months after manufacture date, when installed and maintained in accordance with our instructions. This warranty gives you specific legal rights, and there may also be other rights which vary from state to state. In the event the product is covered by the Federal Consumer Product Warranties Law (1) the duration of any implied warranties associated with the product by virtue of said law is limited to the same duration as stated herein, (2) this warranty is a LIMITED WARRANTY, and (3) no claims of any nature whatsoever shall be made against us, until the ultimate consumer, his successor, or assigns, notifies us in writing of the defect, and delivers the product and/or defective part(s) freight prepaid to our factory or nearest authorized service station. Some states do not allow limitations on how long an implied warranty lasts, so the above limitation may not apply. **THE SOLE AND EXCLUSIVE REMEDY FOR BREACH OF ANY AND ALL WARRANTIES WITH RESPECT TO ANY PRODUCT SHALL BE TO REPLACE OR REPAIR AT OUR ELECTION, F.O.B. POINT OF MANUFACTURE OR AUTHORIZED REPAIR STATION, SUCH PRODUCTS AND/OR PARTS AS PROVEN DEFECTIVE. THERE SHALL BE NO FURTHER LIABILITY, WHETHER BASED ON WARRANTY, NEGLIGENCE OR OTHERWISE.** Unless expressly stated otherwise, guarantees in the nature of performance specifications furnished in addition to the foregoing material and workmanship warranties on a product manufactured by us, if any, are subject to laboratory tests corrected for field performance. Any additional guarantees, in the nature of performance specifications must be in writing and such writing must be signed by our authorized representative. Due to inaccuracies in field testing if a conflict arises between the results of field testing conducted by or for user, and laboratory tests corrected for field performance, the latter shall control. **RECOMMENDATIONS FOR SPECIAL APPLICATIONS OR THOSE RESULTING FROM SYSTEMS ANALYSES AND EVALUATIONS WE CONDUCT WILL BE BASED ON OUR BEST AVAILABLE EXPERIENCE AND PUBLISHED INDUSTRY INFORMATION. SUCH RECOMMENDATIONS DO NOT CONSTITUTE A WARRANTY OF SATISFACTORY PERFORMANCE AND NO SUCH WARRANTY IS GIVEN.**

This warranty shall not apply when damage is caused by (a) improper installation, (b) improper voltage (c) lightning (d) excessive sand or other abrasive material (e) scale or corrosion build-up due to excessive chemical content. Any modification of the original equipment will also void the warranty. We will not be responsible for loss, damage or labor cost due to interruption of service caused by defective parts. Neither will we accept charges incurred by others without our prior written approval.

This warranty is void if our inspection reveals the product was used in a manner inconsistent with normal industry practice and/or our specific recommendations. The purchaser is responsible for communication of all necessary information regarding the application and use of the product. **UNDER NO CIRCUMSTANCES WILL WE BE RESPONSIBLE FOR ANY OTHER DIRECT OR CONSEQUENTIAL DAMAGES, INCLUDING BUT NOT LIMITED TO TRAVEL EXPENSES, RENTED EQUIPMENT, OUTSIDE CONTRACTOR FEES, UNAUTHORIZED REPAIR SHOP EXPENSES, LOST PROFITS, LOST INCOME, LABOR CHARGES, DELAYS IN PRODUCTION, IDLE PRODUCTION, WHICH DAMAGES ARE CAUSED BY ANY DEFECTS IN MATERIAL AND/OR WORKMANSHIP AND/OR DAMAGE OR DELAYS IN SHIPMENT. THIS WARRANTY IS EXPRESSLY IN LIEU OF ANY OTHER EXPRESS OR IMPLIED WARRANTY, INCLUDING ANY WARRANTY OF MERCHANTABILITY OR FITNESS FOR A PARTICULAR PURPOSE.**

No rights extended under this warranty shall be assigned to any other person, whether by operation of law or otherwise, without our prior written approval.

CRANE®

PUMPS & SYSTEMS

A Crane Co. Company

420 Third Street
Piqua, Ohio 45356
(937) 778-8947
Fax (937) 773-7157
www.cranepumps.com

83 West Drive
Brampton, Ont. Canada L6T 2J6
(905) 457-6223
Fax (905) 457-2650

**IMPORTANT!
WARRANTY REGISTRATION**

Your product is covered by the enclosed Warranty.
To complete the Warranty Registration Form go to:

<http://www.cranepumps.com/ProductRegistration/>

If you have a claim under the provision of the warranty, contact your local
Crane Pumps & Systems, Inc. Distributor.

RETURNED GOODS

**RETURN OF MERCHANDISE REQUIRES A "RETURNED GOODS AUTHORIZATION".
CONTACT YOUR LOCAL CRANE PUMPS & SYSTEMS, INC. DISTRIBUTOR.**



**Products Returned Must Be Cleaned, Sanitized,
Or Decontaminated As Necessary Prior To Shipment,
To Insure That Employees Will Not Be Exposed To Health
Hazards In Handling Said Material. All Applicable Laws
And Regulations Shall Apply.**



START-UP REPORT

General Information

Pump Owner's Name: _____
Address: _____
Location of Installation: _____
Contact Person: _____ Phone: _____
Purchased From: _____

Nameplate Data

Pump Model #: _____ Serial #: _____
Part #: _____ Impeller Diameter: _____
Voltage: _____ Phase: _____ Ø Hertz: _____ Horsepower: _____
Full Load Amps: _____ Service Factor Amps: _____
Motor Manufacturer: _____

Controls

Control panel manufacturer: _____
Model/Part number: _____
Number of pumps operated by control panel: _____
Short circuit protection? YES___ NO___ Type: _____
Number and size of short circuit device(s): _____ Amp rating: _____
Overload Type: _____ Size: _____ Amp rating: _____
Do protection devices comply with pump and motor Amp rating? YES___ NO___
Are all electrical and panel entry connections tight? YES___ NO___
Is the interior of the panel dry? YES___ NO___
Liquid level Control Brand and Model: _____

Pre-Startup

All Pumps

Type of equipment: NEW___ REBUILT___ USED___
Condition of equipment at Start-Up: DRY___ WET___ MUDDY___
Was Equipment Stored? YES___ NO___ Length of Storage: _____
Liquid being pumped: _____ Liquid Temperature: _____
Supply Voltage/Phase/Frequency matches nameplate? YES___ NO___
Shaft turns freely? YES___ NO___
Direction of rotation verified for 3Ø motors? YES___ NO___
Debris in piping or wet well? YES___ NO___
Debris removed in your presence? YES___ NO___
Pump case/wet well filled with liquid before startup? YES___ NO___
Is piping properly supported? YES___ NO___

Non-Submersible Pumps

Is base plate properly installed / grouted? YES___ NO___ N/A___
Coupling Alignment Verified per I&O Manual? YES___ NO___ N/A___
Grease Cup/Oil Reservoir Level checked? YES___ NO___ N/A___

Submersible Pumps

Resistance of cable and pump motor (measured at pump control):

Red-Black: _____ Ohms(Ω) Red-White: _____ Ohms(Ω) White-Black: _____ Ohms(Ω)

Resistance of Ground Circuit between Control Panel and outside of pump: _____ Ohms(Ω)

MEG Ohms check of insulation:

Red to Ground: _____ White to Ground: _____ Black to Ground: _____

Operational Checks

Is there noise or vibration present? YES___ NO___ Source of noise/vibration: _____

Does check valve operate properly? YES___ NO___ N/A___

Is system free of leaks? YES___ NO___ Leaks at: _____

Does system appear to operate at design flow rate? YES___ NO___

Nominal Voltage: _____ Phase: 1Ø 3Ø (select one)

Voltage Reading at panel connection, Pump OFF: L1, L2 _____ L2, L3 _____ L1, L3 _____

Voltage Reading at panel connection, Pump ON: L1, L2 _____ L2, L3 _____ L1, L3 _____

Amperage Draw, Pump ON: L1 _____ L2 _____ L3 _____

Submersible Pumps

Are BAF and guide rails level / plumb? YES___ NO___

Is pump seated on discharge properly? YES___ NO___

Are level controls installed away from turbulence? YES___ NO___

Is level control operating properly? YES___ NO___

Is pump fully submerged during operation? YES___ NO___

Follow up/Corrective Action Required

YES___ NO___

Additional Comments:

Startup performed by: _____ Date: _____

Present at Start-Up

() Engineer: _____ () Operator: _____

() Contactor: _____ () Other: _____

All parties should retain a copy of this report for future trouble shooting/reference



PUMPS & SYSTEMS

A Crane Co. Company

420 Third Street
Piqua, Ohio 45356
(937) 778-8947
Fax (937) 773-7157
www.cranepumps.com

83 West Drive
Brampton, Ont. Canada L6T 2J6
(905) 457-6223
Fax (905) 457-2650