

BARNES®

INSTALLATION and OPERATION MANUAL Submersible Sewage Non-Clog Pumps

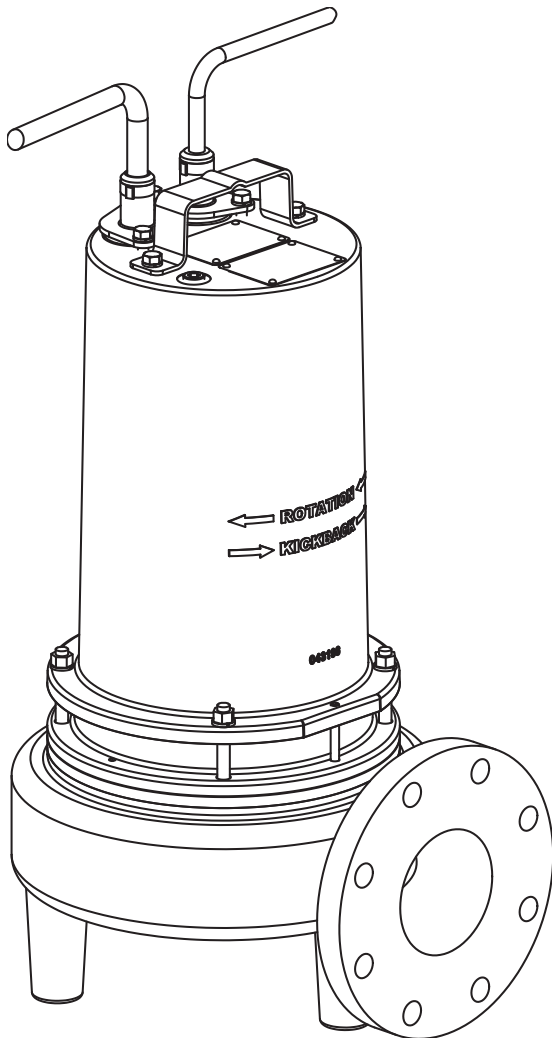

**Series: 4SE-L, 1.9 & 2.8HP
1150RPM, 60Hz**

**Series: 4SE-L, 2.8, 3.7 & 5HP
1750RPM, 60Hz**

**Series: 4SE-L, 5HP
3450RPM, 60Hz**

IMPORTANT!

*Read all instructions in this manual before operating pump.
As a result of Crane Pumps & Systems, Inc., constant product improvement program,
product changes may occur. As such Crane Pumps & Systems reserves the right to
change product without prior written notification.*

CRANE

A Crane Co. Company

PUMPS & SYSTEMS

420 Third Street
Piqua, Ohio 45356
Phone: (937) 778-8947
Fax: (937) 773-7157
www.cranepumps.com

83 West Drive, Brampton
Ontario, Canada L6T 2J6
Phone: (905) 457-6223
Fax: (905) 457-2650



Form No. 133406-Rev. D

TABLE OF CONTENTS

SAFETY FIRST	3
A. PUMP SPECIFICATIONS	4 - 5
B. GENERAL INFORMATION	6
C. INSTALLATION	6 - 7
ELECTRICAL DATA	8
D. START-UP OPERATION	7
E. PREVENTATIVE MAINTENANCE	9
F. SERVICE and REPAIR	9 - 13
G. REPLACEMENT PARTS.....	13
WIRE SCHEMATICS	14
TROUBLE SHOOTING	15
CROSS-SECTION, 1150 & 1750RPM (Fig. 12).....	16
EXPLODED VIEW, 1150 & 1750RPM (Fig. 13).....	17
PARTS LIST	18 - 20
CROSS-SECTION, 3450RPM (Fig. 14).....	21
EXPLODED VIEW, 3450RPM (Fig. 15).....	22
PARTS LIST	23 - 24
WARRANTY	25
RETURNED GOODS POLICY.....	26
WARRANTY REGISTRATION	26
SPECIAL TOOLS AND EQUIPMENT	
INSULATION TESTER (MEGGER)	
DIELECTRIC TESTER	
SEAL TOOL KIT (see parts list)	
PRESSURE GAUGE KIT (see parts list)	

SAFETY FIRST!

Please Read This Before Installing Or Operating Pump.
This information is provided for **SAFETY and to PREVENT EQUIPMENT PROBLEMS**. To help recognize this information, observe the following symbols:



IMPORTANT! Warns about hazards that can result in personal injury or indicates factors concerned with assembly, installation, operation, or maintenance which could result in damage to the machine or equipment if ignored.

CAUTION ! Warns about hazards that can or will cause minor personal injury or property damage if ignored. Used with symbols below.

WARNING ! Warns about hazards that can or will cause serious personal injury, death, or major property damage if ignored. Used with symbols below.



Hazardous fluids can cause fire or explosions, burns or death could result.



Extremely hot - Severe burns can occur on contact.



Biohazard can cause serious personal injury.



Hazardous fluids, hazardous pressure, eruptions or explosions could cause personal injury or property damage.



Rotating machinery Amputation or severe laceration can result.



Hazardous voltage can shock, burn or cause death.

Only qualified personnel should install, operate and repair the pump. Any wiring of pumps should be performed by a qualified electrician.



WARNING ! - To reduce risk of electrical shock, pumps and control panels must be properly grounded in accordance with the National Electric Code (NEC) or the Canadian Electrical Code (CEC) and all applicable state, province, local codes and ordinances.



WARNING! - To reduce risk of electrical shock, always disconnect the pump from the power source before handling or servicing. Lock out power and tag.



WARNING! Operation against a closed discharge valve will cause premature bearing and seal failure on any pump, and on end suction and self priming pump the heat build may cause the generation of steam with resulting dangerous pressures. It is recommended that a high case temperature switch or pressure relief valve be installed on the pump body.



CAUTION ! Never operate a pump with a plug-in type power cord without a ground fault circuit interrupter.



CAUTION! Pumps build up heat and pressure during operation-allow time for pumps to cool before handling or servicing.



WARNING! - **DO NOT** pump hazardous materials (flammable, caustic, etc.) unless the pump is specifically designed and designated to handle them.



Do not block or restrict discharge hose, as discharge hose may whip under pressure.



WARNING! - **DO NOT** wear loose clothing that may become entangled in the impeller or other moving parts.



WARNING! - Keep clear of suction and discharge openings. **DO NOT** insert fingers in pump with power connected.



Always wear eye protection when working on pumps.



Make sure lifting handles are securely fastened each time before lifting. **DO NOT** operate pump without safety devices in place. Always replace safety devices that have been removed during service or repair. Secure the pump in its operating position so it can not tip over, fall or slide.



DO NOT exceed manufacturers recommendation for maximum performance, as this could cause the motor to overheat.



DO NOT remove cord and strain relief. Do not connect conduit to pump.



WARNING! Cable should be protected at all times to avoid punctures, cut, bruises and abrasions - inspect frequently. Never handle connected power cords with wet hands.



WARNING! To reduce risk of electrical shock, all wiring and junction connections should be made per the NEC or CEC and applicable state or province and local codes. Requirements may vary depending on usage and location.



WARNING! Submersible Pumps are not approved for use in swimming pools, recreational water installations, decorative fountains or any installation where human contact with the pumped fluid is common.



WARNING! Products returned must be cleaned, sanitized, or decontaminated as necessary prior to shipment, to insure that employees will not be exposed to health hazards in handling said material. All applicable laws and regulations shall apply.



Bronze/brass and bronze/brass fitted pumps may contain lead levels higher than considered safe for potable water systems. Lead is known to cause cancer and birth defects or other reproductive harm. Various government agencies have determined that leaded copper alloys should not be used in potable water applications. For non-leaded copper alloy materials of construction, please contact factory.



IMPORTANT! - Crane Pumps & Systems, Inc. is not responsible for losses, injury, or death resulting from a failure to observe these safety precautions, misuse or abuse of pumps or equipment.

**SECTION: A - PUMP SPECIFICATIONS:
4SE-L 1150 & 1750RPM 60Hz**

DISCHARGE 4" 125lb Flange, Horizontal
LIQUID TEMPERATURE . 104°F (40°C) Continuous
MOTOR HOUSING Cast Iron ASTM A-48, Class 30
VOLUTE Cast Iron ASTM A-48, Class 20
SEAL PLATE Cast Iron ASTM, Class 30
IMPELLER:
Design 2 Vane, Semi-open with Pump out vanes on Back side. Dynamically balanced, ISO G6.3
Material Cast Iron, Class 30
SHAFT 416 Stainless Steel
SQUARE RINGS Buna-N
DIAPHRAGM Buna-N
HARDWARE 300 Series Stainless Steel
LIFTING BAIL 304 Stainless Steel
PAINT Air dry enamel, top coat (Epoxy Optional)
SEAL: *Design* Double Mechanical in oil filled pressure equalized reservoir
Material Rotating Faces - Carbon
 Stationary Faces - Ceramic
 Elastomer - Buna-N
 Hardware - 300 series stainless steel
CORD ENTRY 30 Ft. (9.1m) Cord. Quick connect custom molded for sealing and strain relief.

SPEED 1150, 1750 RPM, 60Hz (nominal),
BEARINGS:
Upper Single Row, Ball, Oil Lubricated
Load Radial
Lower Single Row, Ball, Oil Lubricated
Load Radial
Life 50,000 HR L10 Design
MOTOR: *Design* NEMA L, Single phase, NEMA B, Three Phase Torque Curve, Oil Filled, Squirrel Cage Induction
Winding Class B, Class H Rated Magnet Wire Class F on selected models
Service Factor 1.15
SINGLE PHASE Permanent Split Capacitor (PSC). Includes overload protection in motor
THREE PHASE 200-230/460, 60Hz is Tri voltage motor. 575V. Requires overload protection to be included in control panel, VFD Suitable
MOISTURE SENSOR N/O, Requires relay in control panel
TEMP. SENSOR N/C, Requires relay in control panel
OPTIONAL EQUIPMENT.. Seal Material, Impeller Trims, Additional Cord, Epoxy Paint

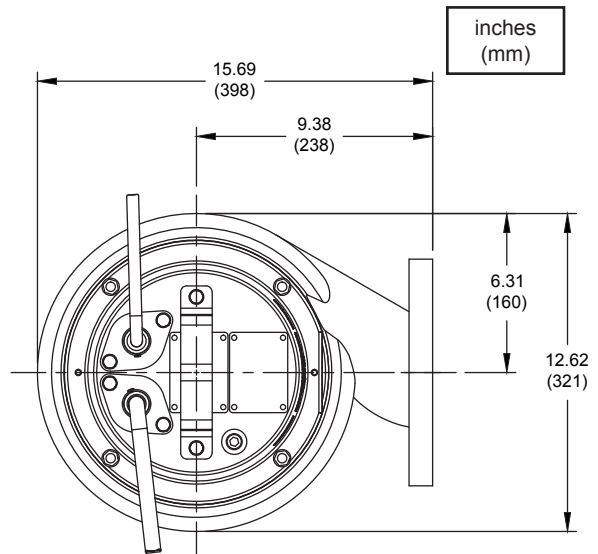
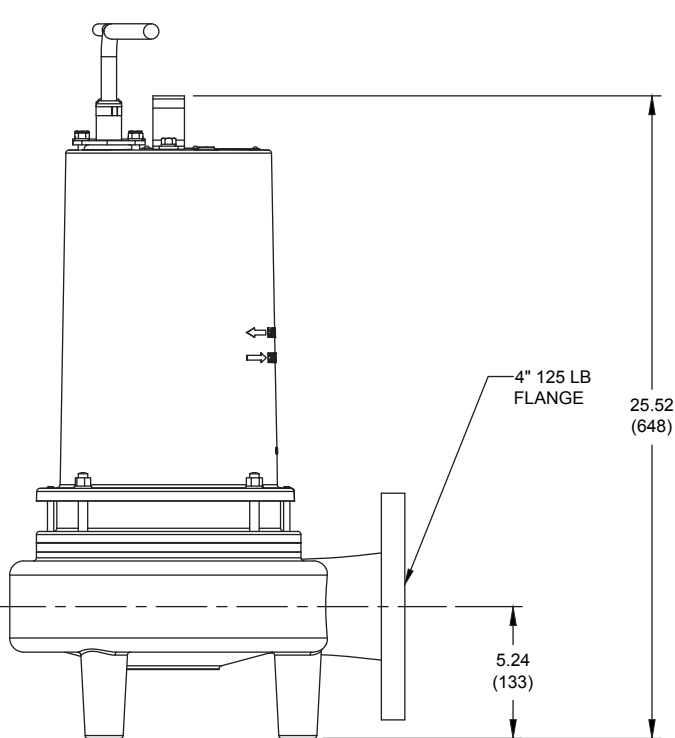

IMPORTANT !

- 1.) PUMP MAY BE OPERATED "DRY" FOR EXTENDED PERIODS WITHOUT DAMAGE TO MOTOR AND/OR SEALS.
- 2.) THIS PUMP IS APPROPRIATE FOR THOSE APPLICATIONS SPECIFIED AS CLASS I DIVISION 2 HAZARDOUS LOCATIONS.
- 3.) THIS PUMP IS NOT APPROPRIATE FOR THOSE APPLICATIONS SPECIFIED AS CLASS I DIVISION 1 HAZARDOUS LOCATIONS.
- 4.) INSTALLATIONS SUCH AS DECORATIVE FOUNTAINS OR WATER FEATURES PROVIDED FOR VISUAL ENJOYMENT MUST BE INSTALLED IN ACCORDANCE WITH THE NATIONAL ELECTRIC CODE ANSI/NFPA 70 AND/OR THE AUTHORITY HAVING JURISDICTION. THIS PUMP IS NOT INTENDED FOR USE IN SWIMMING POOLS, RECREATIONAL WATER PARKS, OR INSTALLATIONS IN WHICH HUMAN CONTACT WITH PUMPED MEDIA IS A COMMON OCCURRENCE.

**SECTION: A - PUMP SPECIFICATIONS:
4SE-L 3450RPM 60Hz**

DISCHARGE 4" 125lb Flange, Horizontal
LIQUID TEMPERATURE . 104°F (40°C) Continuous
MOTOR HOUSING Cast Iron ASTM A-48, Class 30
VOLUTE Cast Iron ASTM A-48, Class 20
SEAL PLATE Cast Iron ASTM, Class 30
IMPELLER:
Design 2 Vane, Semi-open with Pump out vanes on Back side. Dynamically balanced, ISO G6.3
Material Cast Iron, Class 30
SHAFT 416 Stainless Steel
SQUARE RINGS Buna-N
DIAPHRAGM Buna-N
HARDWARE 300 Series Stainless Steel
LIFTING BAIL 304 Stainless Steel
PAINT Air dry enamel, top coat (Epoxy Optional)
SEAL *Design* Double Mechanical in oil filled pressure equalized reservoir
Material Rotating Faces - Carbon
 Stationary Faces - Ceramic
 Elastomer - Buna-N
 Hardware - 300 series stainless steel
CORD ENTRY 30 Ft. (9.1m) Cord. Quick connect custom molded for sealing and strain relief.

SPEED 3450RPM, 60Hz (nominal)
BEARINGS:
Upper Single Row, Ball, Oil Lubricated
Load Radial
Lower Single Row, Ball, Oil Lubricated
Load Radial
Life 50,000 HR L10 Design
MOTOR: *Design* NEMA L, Single phase, NEMA B, Three Phase Torque Curve, Oil Filled, Squirrel Cage Induction
Winding Class B, Class H Rated Magnet Wire
Service Factor 1.15
THREE PHASE Dual voltage 230/460 motor. 575V. Requires overload protection to be included in control panel, VFD Suitable
MOISTURE SENSOR N/O, Requires relay in control panel
TEMP. SENSOR N/C, Requires relay in control panel
OPTIONAL EQUIPMENT . Seal Material, Impeller Trims, Additional Cord, Epoxy Paint

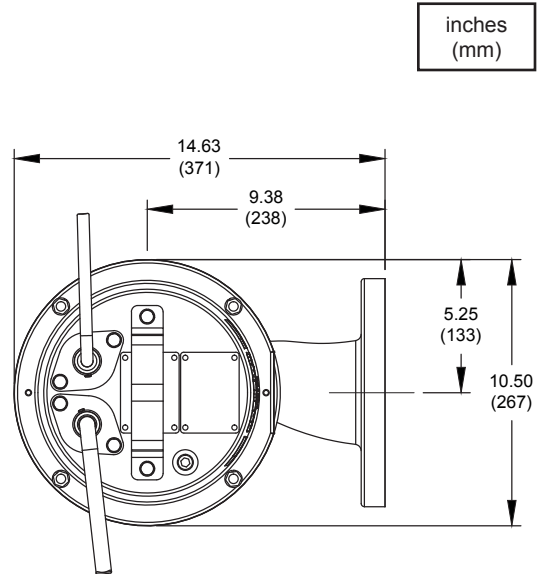
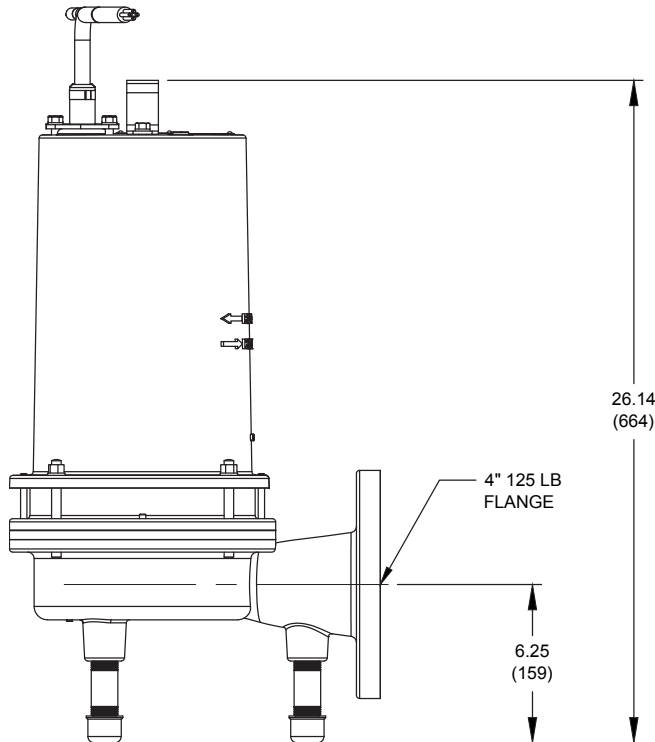

IMPORTANT !

- 1.) PUMP MAY BE OPERATED "DRY" FOR EXTENDED PERIODS WITHOUT DAMAGE TO MOTOR AND/OR SEALS.
- 2.) THIS PUMP IS APPROPRIATE FOR THOSE APPLICATIONS SPECIFIED AS CLASS I DIVISION 2 HAZARDOUS LOCATIONS.
- 3.) THIS PUMP IS NOT APPROPRIATE FOR THOSE APPLICATIONS SPECIFIED AS CLASS I DIVISION 1 HAZARDOUS LOCATIONS.
- 4.) INSTALLATIONS SUCH AS DECORATIVE FOUNTAINS OR WATER FEATURES PROVIDED FOR VISUAL ENJOYMENT MUST BE INSTALLED IN ACCORDANCE WITH THE NATIONAL ELECTRIC CODE ANSI/NFPA 70 AND/OR THE AUTHORITY HAVING JURISDICTION. THIS PUMP IS NOT INTENDED FOR USE IN SWIMMING POOLS, RECREATIONAL WATER PARKS, OR INSTALLATIONS IN WHICH HUMAN CONTACT WITH PUMPED MEDIA IS A COMMON OCCURRENCE.

SECTION B: GENERAL INFORMATION

B-1) To the Purchaser:

Congratulations! You are the owner of one of the finest pumps on the market today. CP&S pumps are products engineered and manufactured of high quality components. Over one hundred years of pump building experience along with a continuing quality assurance program combine to produce a pump which will stand up to the toughest applications. This manual will provide helpful information concerning installation, maintenance, and proper service guidelines.

B-2) Receiving:

Upon receiving the pump, it should be inspected for damage or shortages. If damage has occurred, file a claim immediately with the company that delivered the pump. If the manual is removed from the packaging, do not lose or misplace.

B-3) Storage:

Short Term- CP&S Pumps are manufactured for efficient performance following short inoperative periods in storage. For best results, pumps can be retained in storage, as factory assembled, in a dry atmosphere with constant temperatures for up to six (6) months.

Long Term- Any length of time exceeding six (6) months, but not more than twenty-four (24) months. The unit should be stored in a temperature controlled area, a roofed over walled enclosure that provides protection from the elements (rain, snow, wind-blown dust, etc.), and whose temperature can be maintained between +40°F and +120°F. (4.4 - 49°C).

Pump should be stored in its original shipping container. On initial start up, rotate impeller by hand to assure seal and impeller rotate freely. If it is required that the pump be installed and tested before the long term storage begins, such installation will be allowed provided:

- 1.) The pump is not installed under water for more than one (1) month.
- 2.) Immediately upon satisfactory completion of the test, the pump is removed, thoroughly dried, repacked in the original shipping container, and placed in a temperature controlled storage area.

B-4) Service Centers:

For the location of the nearest CP&S Service Center, check with your CP&S representative or Crane Pumps & Systems Service Department in Piqua, Ohio, telephone (937) 778-8947 or Crane Pumps & Systems Canada, in Brampton, Ontario, (905) 457-6223.

SECTION C: INSTALLATION

C-1) Location:

These pumping units are self-contained and are recommended for use in a sump, lift station or basin. The sump, lift station or basin shall be vented in accordance with local plumbing codes. This pump is designed to pump sewage, effluent, or other nonexplosive or noncorrosive wastewater and shall NOT be installed in locations classified as Class I Division 1 hazardous in accordance with the National Electrical Code (NEC), ANSI/NFPA 70 or the Canadian Electrical Code. Never install the pump in a trench, ditch or hole with a dirt bottom; the legs will sink into the dirt and the suction will become plugged.

C-1.1 Submergence:

It is recommended that the pump be operated in the submerged condition and the sump liquid level should never be less than dimension "A" in Figure 1.

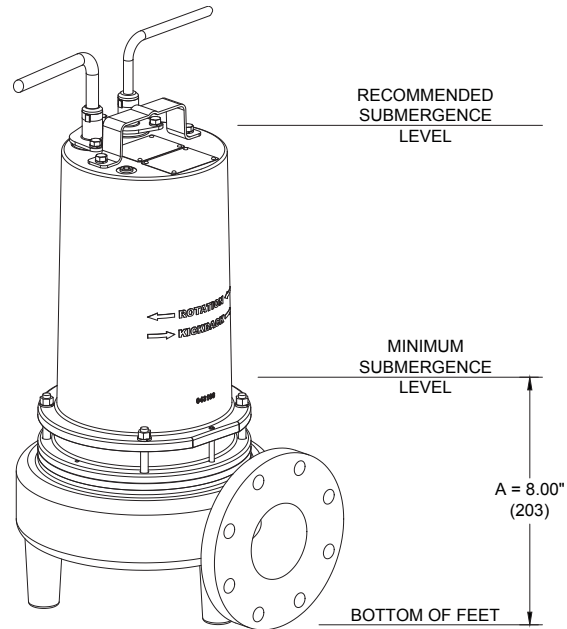

FIGURE 1

C-2) Discharge:

Discharge piping should be as short as possible. Both a check valve and a shut-off valve are recommended for each pump being used. The check valve is used to prevent backflow into the sump. Excessive backflow can cause flooding and/or damage to the pump. The shut-off valve is used to stop system flow during pump or check valve servicing.

CP&S supplies a breakaway fitting discharge system designed to allow the submersible wastewater pump to be installed or removed without requiring personnel to enter the wet well.

Place the Break Away Fitting (BAF) in position. Temporarily secure the guide rails in the upper mounting brackets and locate the base on the bottom of the wet well. Level the base with grout and/or shims. Install the intermediate support brackets, if required. Make sure the rails are in a true vertical position so the pump will clear the access opening and will slide freely down the rails into place on the discharge stationary fitting. Once the rails are in proper alignment, bolt the base into the floor of the station and connect the discharge pipe to the elbow. Connect the movable portion and other supplied fittings of the BAF onto the pump and lower into wet well. See the Break Away Fitting manual for more information.

C-3) Liquid Level Controls:

The level controls are to be supported by a mounting bracket that is attached to the sump wall, cover or junction box. Cord grips are used to hold the cords in place on the mounting bracket. The control level can be changed by loosening the grip and adjusting the cord length as per the plans and specifications. Be certain that the level controls cannot hang up or foul in it's swing and that the pump is completely submerged when the level control is in the "Off" mode.

C-4) Electrical Connections:

C-4.1) Power & Sensor Cords:

The cord assembly mounted to the pump must not be modified in any way except for shortening to a specific application. Any splice between the pump and the control panel must be made in accordance with all applicable electric codes. It is recommended that a junction box, if used, be mounted outside the sump or be of at least NEMA 4 (EEMAC-4) construction if located within the wet well. **DO NOT USE THE POWER OR SENSOR CORDS TO LIFT PUMP.**

NOTE: The White Wire Is Not A Neutral Or Ground Lead. The Black, White And Red Leads Are Power Carrying Conductors. The Green Lead Is For Connection To Ground.

C-4.2) Overload Protection :

C-4.2-1) Three Phase - The normally closed (N/C) thermal sensor is embedded in the motor windings and will detect excessive heat in the event an overload condition occurs. The thermal sensor will trip when the windings become too hot and will automatically reset itself when the pump motor cools to a safe temperature. It is recommended that the thermal sensor be connected in series to an alarm device to alert the operator of an overload condition, and/or the motor starter coil to stop the pump. In the event of an overload, the source of this condition should be determined and rectified immediately. **DO NOT LET THE PUMP CYCLE OR RUN IF AN OVERLOAD CONDITION OCCURS !**

C-4.2-2) Single Phase - The type of in-winding overload protector used is referred to as an inherent overheating protector and operates on the combined effect of temperature and current. This means that the overload protector will trip out and shut the pump off if the windings become too hot, or the load current passing through them becomes too high. It will then automatically reset and start the pump up after the motor cools to a safe temperature. In the event of an overload, the source of this condition should be determined and rectified immediately. **DO NOT LET THE PUMP CYCLE OR RUN IF AN OVERLOAD CONDITION OCCURS !**

C-4.3) Moisture Sensors:

A normally open (N/O) detector is installed in the pump seal chamber which will detect any moisture present. It is recommended that this detector be connected in series to an alarm device or the motor starter coil to alert the operator that a moisture detect has occurred. In the event of a moisture detect, check the individual moisture sensor probe leads for continuity, (∞ resistance = no moisture) and the junction box/control box for moisture content. The above situations may induce a false signal in the moisture detecting circuit. If none of the above test prove conclusive, the pump(s) should be pulled and the source of the failure identified and repaired. **IF A MOISTURE DETECT HAS OCCURRED SCHEDULE MAINTENANCE AS SOON AS POSSIBLE.**

If current through the temperature sensor exceeds the values listed, an intermediate control circuit relay must be used to reduce the current or the sensor will not work properly.

TEMPERATURE SENSOR ELECTRICAL RATINGS		
Volts	Continuous Amperes	Inrush Amperes
220-240	1.50	15.0
440-480	0.75	7.5
575-600	0.60	6.0

C-4.4) Wire Size:

Consult a qualified electrician for proper wire size if additional power cable is required. See table for electrical information.

SECTION: D START-UP OPERATION

D-1) Check Voltage and Phase:

Before operating pump, compare the voltage and phase information stamped on the pump identification plate to the available power.

D-2) Check Pump Rotation:

Before putting pump into service for the first time, the motor rotation must be checked. Improper motor rotation can result in poor pump performance and can damage the motor and/or pump. To check the rotation, suspend the pump freely, momentarily apply power and observe the "kickback". "Kickback" should always be in a counter-clockwise direction as viewed from the top of the pump motor housing.

D-2.1) Incorrect Rotation for Three-Phase Pumps:

In the event that the rotation is incorrect for a three-phase installation, interchange any two power cable leads at the control box. **DO NOT** change leads in the cable housing in the motor. Recheck the "kickback" rotation again by momentarily applying power.

D-2.2) Incorrect Rotation for Single-Phase Pumps:

In the unlikely event that the rotation is incorrect for a single phase pump, contact a CP&S Service Center.

D-3) Identification Plate:

Record the numbers from the pump identification plate for future reference.

D-3.1) Insulation Test:

Before the pump is put into service, an insulation (megger) test should be performed on the motor. The resistance values (ohms) as well as the voltage (volts) and current (amps) should be recorded.

D-3.2) Pump-Down Test:

After the pump has been properly wired and lowered into the basin, sump or lift station, it is advisable to check the system by filling with liquid and allowing the pump to operate through its pumping cycle. The time needed to empty the system, or pump-down time along with the volume of water, should be recorded.

MODEL NO	HP	VOLT/PH	Hz	RPM (Nom)	NEMA START CODE	INSUL. CLASS	FULL LOAD AMPS	LOCKED ROTOR AMPS	CORD SIZE	CORD TYPE	CORD O.D inch (mm)	EMERSON Winding Resistance Main - Start	G.E. Winding Resistance Main - Start
4SE1926L	1.9	230/1	60	1150	D	B	8.3	35.0	14/3	SOOW/SOW	.53 (13.5)	6.55 - 24.21	8.29 - 14.99
4SE1996L	1.9	200-230/3	60	1150	E/G	B	5.8/5.0	26.1/30.0	14/4	SOOW/SOW	.57 (14.5)	4.40	5.16
4SE1946L	1.9	460/3	60	1150	G	B	2.5	15.0	14/4	SOOW/SOW	.57 (14.5)	17.60	20.64
4SE1956L	1.9	575/3	60	1150	G	B	2.0	12.0	14/4	SOOW/SOW	.57 (14.5)		32.39
4SE2826L	2.8	230/1	60	1150	A	B	13.5	31.0	12/3	SOOW/SOW	.61 (15.5)	6.55 - 24.21	8.29 - 14.99
4SE2896L	2.8	200-230/3	60	1150	F/H	B	9.2/8.4	38.2/44.0	14/4	SOOW/SOW	.57 (14.5)	4.40	5.16
4SE2846L	2.8	460/3	60	1150	H	B	4.2	22.0	14/4	SOOW/SOW	.57 (14.5)	17.60	20.64
4SE2856L	2.8	575/3	60	1150	H	B	3.4	17.6	14/4	SOOW/SOW	.57 (14.5)		32.39
4SE2824L	2.8	230/1	60	1750	A	B	12.6	23.0	12/3	SOOW/SOW	.61 (15.5)	2.53	1.17 - 5.89
4SE2894L	2.8	200-230/3	60	1750	D/H	B	9.2/8.0	35.9/42.7	12/4	SOOW/SOW	.68 (17.4)	7.64	1.77
4SE2844L	2.8	460/3	60	1750	G	B	4.0	21.3	14/4	SOOW/SOW	.57 (14.5)		10.64
4SE2854L	2.8	575/3	60	1750	F	B	3.2	14.4	14/4	SOOW/SOW	.57 (14.5)	4.68	16.63
4SE3724L	3.7	230/1	60	1750	A	B	20.0	29.0	10/3	SOOW/SOW	.66 (16.8)	1.91	1.37
4SE3794L	3.7	200-230/3	60	1750	B/E	B	16.1/14.0	35.9/42.7	12/4	SOOW/SOW	.68 (17.4)	7.64	1.77
4SE3744L	3.7	460/3	60	1750	E	B	7.0	21.3	14/4	SOOW/SOW	.57 (14.5)		7.08
4SE3754L	3.7	575/3	60	1750	G	B	5.6	21.6	14/4	SOOW/SOW	.57 (14.5)		11.39
4SE5024L	5.0	230/1	60	1750	A	F	28.0	59.0	10/3	SOOW/SOW	.66 (16.8)		0.60 - 2.20
4SE5094L	5.0	200-230/3	60	1750	B/D	F	20.9/19.0	48.6/56.0	10/4	SOOW/SOW	.72 (18.5)		1.66
4SE5044L	5.0	460/3	60	1750	D	F	9.0	28.0	14/4	SOOW/SOW	.57 (14.5)		6.30
4SE5054L	5.0	575/3	60	1750	E	B	8.3	23.0	14/4	SOOW/SOW	.57 (14.5)		6.60
4SE5032L	5.0	230/3	60	3450	B	B	16.4	40.0	12/4	SOOW/SOW	.68 (17.4)		1.80
4SE5042L	5.0	460/3	60	3450	B	B	8.2	20.0	14/4	SOOW/SOW	.57 (14.5)		7.20
4SE5052L	5.0	575/3	60	3450	B	B	6.5	16.0	14/4	SOOW/SOW	.57 (14.5)		11.10

Winding Resistance \pm 5%, measured from terminal block. Pump rated for operation at \pm 10% voltage at motor.

Moisture/Temperature sensor cord for all phase models is 18/5, 0.47 (11.9mm) O.D.

SECTION E: PREVENTATIVE MAINTENANCE

As the motor is oil filled, no lubrication or other maintenance is required, and generally CP&S pumps will give very reliable service and can be expected to operate for years on normal sewage pumping without failing. However as with any mechanical piece of equipment a preventive maintenance program is recommended and suggested to include the following checks:



WARNING ! - Pressure builds up due to heat.

- 1) Inspect motor chamber for oil level and contamination and repair as required per section F-1.
- 2) Inspect impeller and body for excessive build-up or clogging and repair as required per section F-2.
- 3) Inspect motor and bearings and replace as required per section F-3.
- 4) Inspect seal for wear or leakage and repair as required per section F-4.

SECTION F: SERVICE AND REPAIR

NOTE: All item numbers in () refer to Figures 12, 13, 14 & 15.

F-1) Lubrication:

Anytime the pump is removed from operation, the cooling oil in the motor housing (2) should be checked visually for oil level and contamination.

F-1.1) Checking Oil:

Motor Housing - To check oil, set unit upright. Remove pipe plug (5) from motor housing (2). With a flashlight, visually inspect the oil in the motor housing (2) to make sure it is clean and clear, light amber in color and free from suspended particles. Milky white oil indicates the presence of water. Oil level should be just above the motor when pump is in a vertical position.

F-1.2) Testing Oil:

1. Place pump on it's side, remove pipe plug (5), from motor housing (2) and drain oil into a clean, dry container.
2. Check oil for contamination using an oil tester with a range to 30 Kilovolts breakdown.
3. If oil is found to be clean and uncontaminated (measure above 15 KV. breakdown), refill the motor housing as per section F-1.4.
4. If oil is found to be dirty or contaminated (or measures below 15 KV. breakdown), the the pump must be carefully inspected for leaks at the shaft seal (46), cable assemblies (52) and (53), square ring (42) and pipe plug (5) before refilling with oil. To locate the leak, perform a pressure test as per section F-1.3. After leak is repaired, refill with new oil as per section F-1.4.

F-1.3) Pressure Test:

Pumps that have had the oil drained from the Motor Housing - Apply pipe sealant to pressure gauge assembly and tighten into pipe plug hole (See Figure 2). Pressurize motor housing to 10 P.S.I. Use soap solution around the sealed areas and inspect joints for "air bubbles". If, after five minutes, the pressure is still holding constant, and no "bubbles" are observed, slowly bleed the pressure and remove the gauge assembly. Replace oil as described in section F-1.4. If the pressure does not hold, then the leak must be located and repaired.

Pumps that have NOT had the oil drained from the Motor Housing - The pressure test may be done with the oil at its normal level. Remove pipe plug (5) from motor housing (2). Apply pipe sealant to pressure gauge assembly and tighten into hole (see Figure 2). Pressurize motor housing to 10 P.S.I. Use soap solution around the sealed areas above the oil level and inspect joints for "air bubbles". For sealed areas below the oil level, leaks will seep oil.

If, after five minutes, the pressure is still holding constant, and no "bubbles"/oil seepage is observed, slowly bleed the pressure and remove the gauge assembly. If the pressure does not hold, then the leak must be located and repaired.

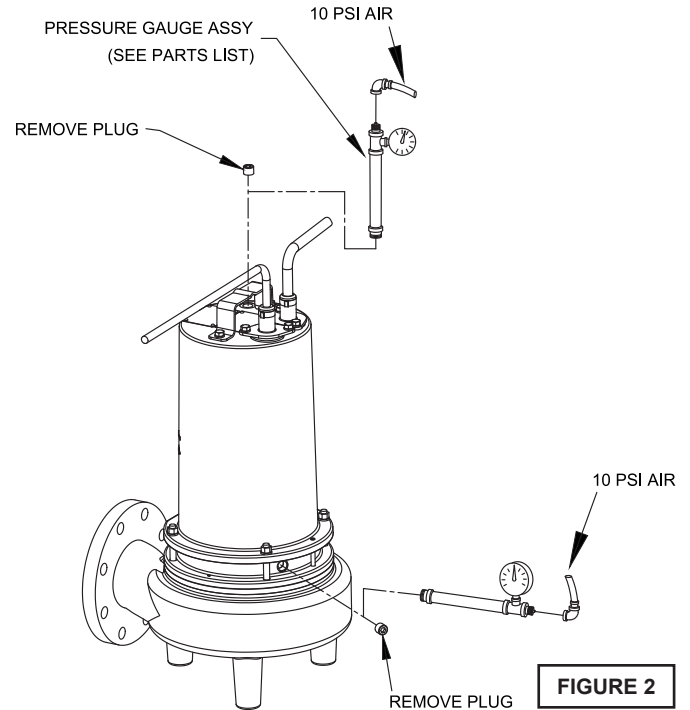

FIGURE 2



CAUTION ! - Pressure builds up extremely fast, increase pressure by "TAPPING" air nozzle. Too much pressure will damage seal. DO NOT exceed 10 P.S.I.

Seal Chamber - Set unit on its side with fill plug (5) downward, remove plug (5) and drain all oil from seal chamber. Apply pipe sealant to pressure gauge assembly and tighten into hole in bearing bracket (21). Pressurize seal chamber to 10 P.S.I. and check for leaks as outlined above.

F-1.4) Replacing Oil:

Motor Housing - Set unit upright and refill with new cooling oil as per Table 1 (see parts list for amount). Fill to just above motor as an air space must remain in the top of the motor housing to compensate for oil expansion (see Figure 2, 12 or 14). Apply pipe thread compound to threads of pipe plug (5) then assemble to motor housing (2).



IMPORTANT! - For single phase units, oil level should be below capacitor.

Seal Chamber - Set unit on its side, with plug (5) upward, and refill with new oil as per Table 1 (see parts list for amount). Apply pipe thread compound to threads of pipe plug (5) and assemble to bearing bracket (21).



WARNING ! - DO NOT overfill oil.
Overfilling of motor housing with oil can create excessive and dangerous hydraulic pressure which can destroy the pump and create a hazard. Overfilling oil voids warranty.

TABLE 1 - COOLING OIL - Dielectric	
SUPPLIER	GRADE
Sohio / Standard	SE 40, Energol HL22 or HL32
Shell	Turbo Oil 32
Texaco	Rando HD32, 522
Sun Petroleum	Supar 110, Sunvis 816WR, 911 or 916
Mobile	D.T.E. Oil Light or Rubrex 200
G&G	Circu Oil 22
Allegheny Petroleum	Altrapar 22
Woco	Premium 100

F-2) Impeller and Volute Service:

F-2.1) Disassembly and Inspection:

To clean out volute (26), disconnect power, remove hex nuts (20), and lock washers (19), vertically lift motor and seal assembly from volute (26). Clean out volute if necessary. Clean and examine impeller (28), for pitting or wear, replace if required, inspect Square Ring (42) and replace if cut or damaged. If the impeller (28) requires replacing, remove hex nut (34) and washer (35). The impeller is keyed onto the shaft with a square key (33) and to remove, pull impeller straight off the shaft using a wheel puller, if required. Before reinstalling, check the motor shaft and impeller bore for damage.

F-2.2) Reassembly:

To install impeller (28), apply a thin film of oil to motor shaft and slide impeller straight onto shaft, keeping keyways lined up. Drive key (33) into keyway. Locate washer (35), apply thread locking compound to shaft threads, thread hex nut (34) to shaft and torque to 40 ft. lbs. Rotate impeller to check for binding.

Position square ring (42) on volute flange and install impeller and motor housing over studs and onto volute (26). Apply thread locking compound to threads of each stud (24), install lock washer (19) and thread nuts (20) onto stud (24). Torque to 20 ft. lbs. Check for free rotations of motor and impeller.

F-3) Motor and Bearing Service:

F-3.1) Disassembly and Inspection:

To examine or replace the motor (1), capacitor (3, single phase units), and bearing (47), drain oil from motor as outlined in paragraph F-1.2. Disassemble volute and impeller as outlined in paragraph F-2.1 and disassemble shaft seal as outlined in paragraph F-4.1. Position unit upright, using blocks to avoid resting unit on shaft. Unscrew cord hex bolts (6) and remove compression flange (52a) and power cord (52). Remove snap ring (54) with a flat head screwdriver. Pull the terminal block (56) out of the housing (2) using a T-bolt or pair of pliers and a .25-20 screw in the threads of the terminal block (56). Be sure to leave slack on the motor leads connected underneath. Use needle nose pliers to pull each female connector off of the pins on the underside of the terminal block (56) (see Figure 5). The unit voltage should be noted. Repeat cord and terminal block removal procedure for any sensor cords (53). Remove socket head cap screws (51).

Vertically lift motor housing (2) from bearing bracket (21) by lifting handle (7). Inspect square ring (42) for damage or cuts. Remove the motor bolts and lift motor stator from bearing bracket (21). Disconnect capacitor leads from capacitor (3, 1 phase units). Examine bearing (47) and replace if required. If replacement is required, remove bearing (47) from motor shaft using a wheel puller or arbor press, see Figure 4.

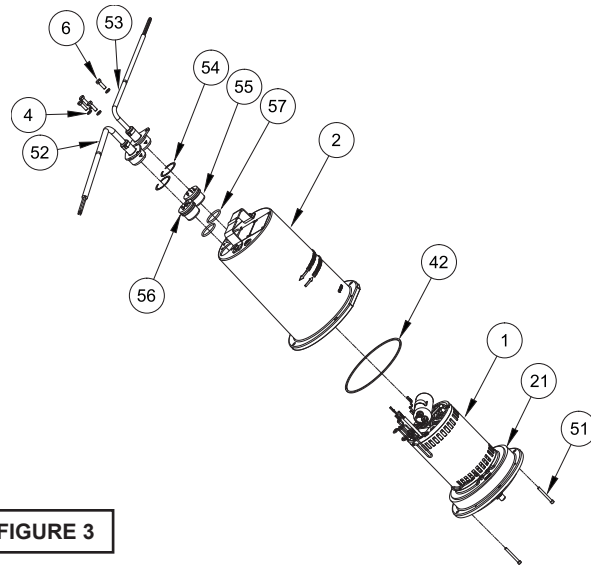

FIGURE 3

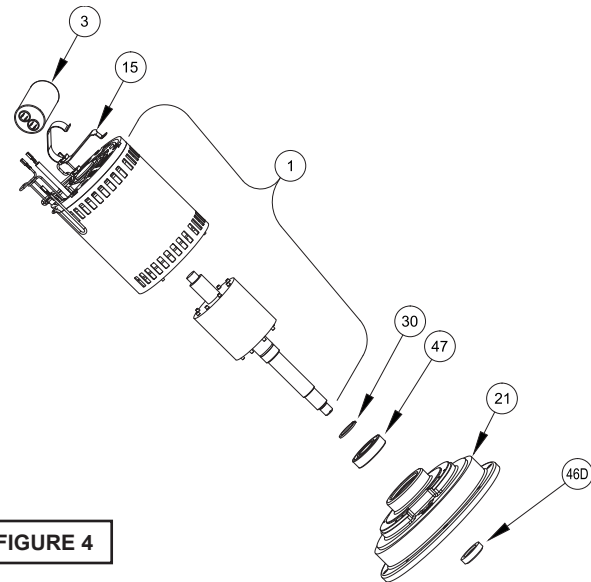

FIGURE 4

Check motor capacitor (3, 1 phase units) with an Ohm meter by first grounding the capacitor by placing a screwdriver across both terminals and then removing screwdriver. Connect Ohm meter (set on high scale) to terminals. If needle moves to infinity (∞) then drifts back, the capacitor is good. If needle does not move or moves to infinity (∞) and does not drift back, replace capacitor (3). To test the temperature sensor (P1/P2), check for continuity between the wire leads (see Figure 11). If found to be defective, contact a motor service station or CP&S Pumps Service department. Inspect motor winding for shorts and check resistance values. Check rotor for wear. If rotor or the stator windings are defective, the complete motor must be replaced. While disassembled, check moisture sensor wires (16) (if equipped), that they are secured to electrodes (18) with screws (14).

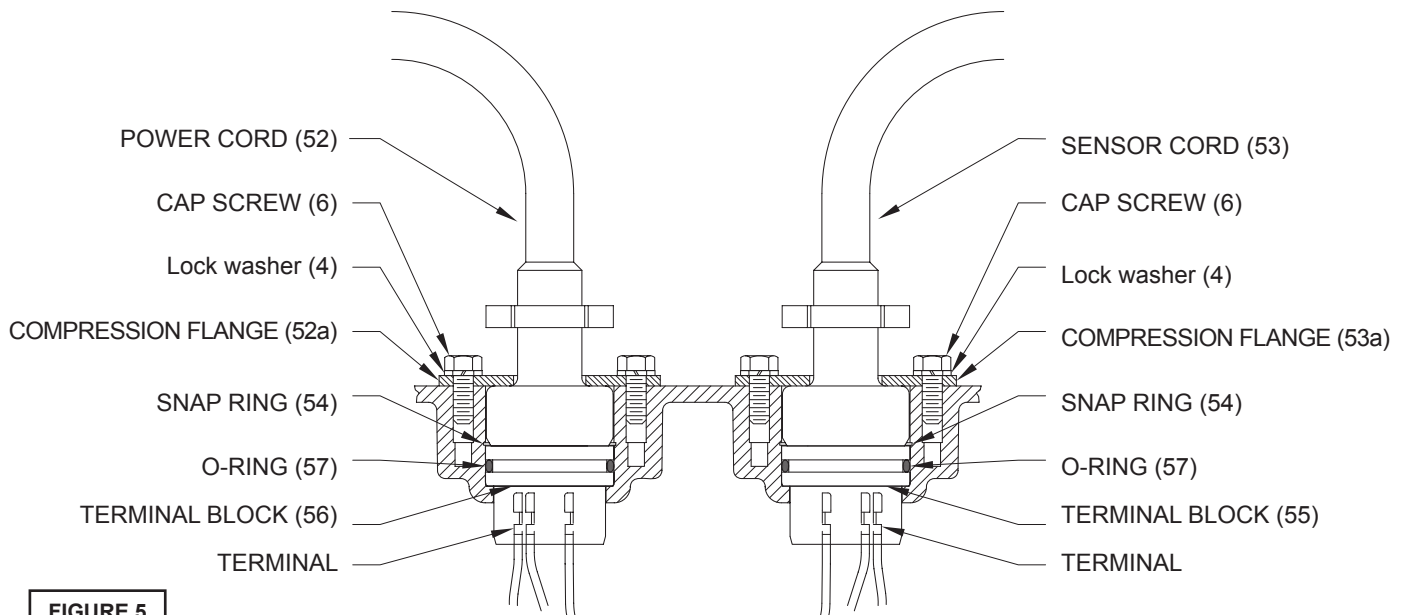

FIGURE 5



IMPORTANT! - All parts must be clean before reassembly.

F-3.2) Reassembly:

Bearing - When replacing bearing, be careful not to damage the rotor or shaft threads. Clean the shaft thoroughly. Apply adhesive compound to the shaft and press bearing (47) on the motor shaft, position squarely onto the shaft applying force to the inner race of the bearing only, until bearing seats against the retaining ring (30).

Moisture Sensors - If pump is equipped with moisture sensors, reassemble by applying thread compound to threads on electrodes (18) and install in bearing bracket (21). Connect wire assemblies (16) to electrodes (18) with machine screws (14).

Thermal Sensors - If pump is equipped with Thermal Sensor, connect sensor leads to terminal block (55) as shown in Figure 11. If sensor is not functioning, contact factory approved service center or contact factory service department.

Motor - Slide lower bearing (47) and motor shaft squarely into the bearing bracket (21) until bearing seats on the bottom. Install retaining ring (29) in bearing bracket (21). Place stator over rotor, lining up motor bolts with holes in bearing bracket (21). Position capacitor (3, 1 phase units) so that it will lay on the opposite side of the cord entry bosses of the motor housing (2). Reconnect capacitor leads. Torque motor tie bolts to 22 in-lbs. Set square ring (42) in groove on bearing bracket (21).

F-3.3) Wiring Connections:

Check power cord (52) and sensor cord (53), for cracks or damage and replace if required. Make internal wiring connections which are independent of the terminal block as shown in (Figure 12), using connectors (11) and wire assemblies (12) as required. Do not use wire nuts. Slip motor leads and ground wire through fiberglass sleeve (10). Lower motor housing (2) down onto bearing bracket (21) while aligning holes and stringing motor leads through the cable entry bore(s). (Slipping cords inside a 1 ft. length of .5"

conduit makes this easier). Place socket head cap screws (51) into motor housing (2) and torque to 75 in-lbs. Install inner seal assembly as outlined in paragraph F-4.2. Install square ring (42), bearing bracket (21), square ring (42) in position on pump. Place socket head cap screws (39) into seal plate (25) and torque to 75 in-lbs.

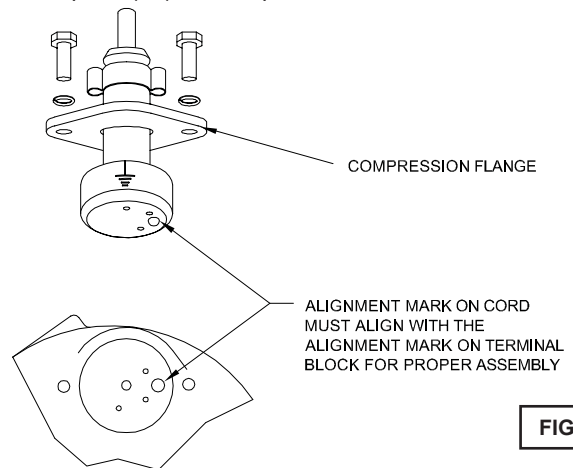

FIGURE 6

Reconnect motor and sensor leads to the underside of the terminal block(s) (56), (55) as shown in Figure 5 & 11. Note that the pins are numbered underneath the terminal block. Place o-ring (57) into groove in terminal block and lubricate with dielectric oil. Press the terminal blocks (55) (56) into the housing so it seats completely below the snap ring groove. Place snap ring (54) into groove in cord entry bore of motor housing (2). Repeat terminal block installation for sensor cord, if equipped.

F-3.4) Cord Assemblies:

Power/Sensor Cord - Refill the cooling oil as outlined in paragraph F-1.4. Make wire connections as outlined in paragraph F-3.3. Insert female end of cable plug into housing bore aligning timing mark with hole in terminal block (55) (56) (see Figure 6). Compress cord plug with compression flange (52a)(53a) by tightening cap screws (6) into the motor housing (2). Torque to 132 in-lbs.

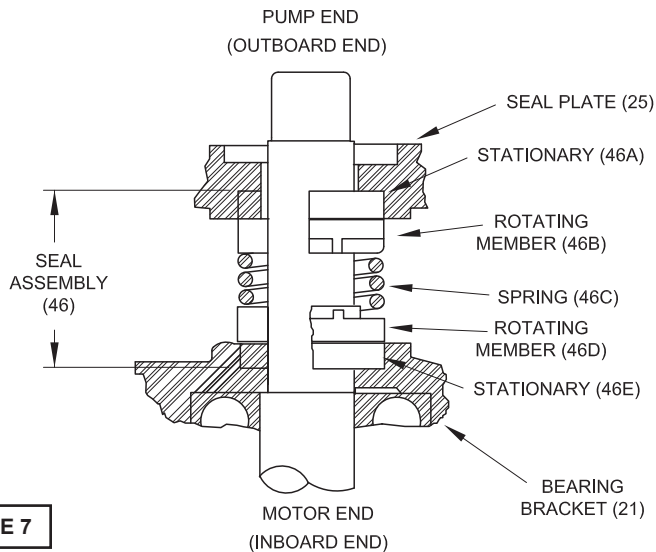

FIGURE 7

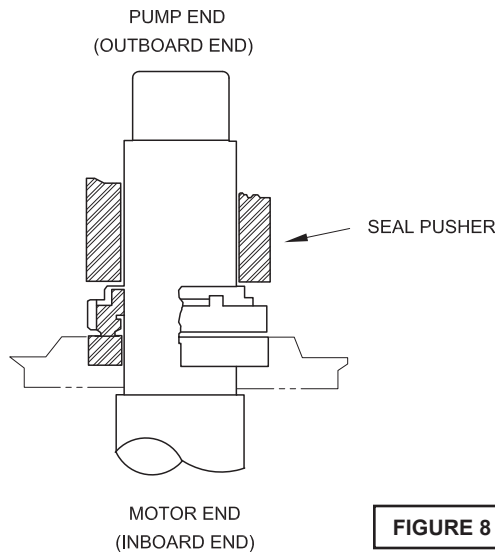

FIGURE 8

F-4) Shaft Seal and Diaphragm Service:

Important! - Handle seal parts with extreme care. **DO NOT** scratch or mar lapped surfaces.

F-4.1) Disassembly and Inspection:

Diaphragm - To examine or replace the diaphragm (32) or shaft seal (46), remove impeller (28) as outlined in paragraph F-2.1. Drain oil from seal chamber as outlined in paragraph F-1.2. Remove cap screws (6), lock washers (4), handle (7), power cord (52) and sensor cord (53) from top on motor housing (2). Set unit upside down. Remove socket head cap screws (39) and lift seal plate (25) vertically, being cautious to avoid seal damage, together with diaphragm (32), clamp (43) and outboard stationary member (46A) of shaft seal (46), from bearing bracket (21). Examine diaphragm (32), if it is ruptured, cracked or damaged, replace by removing screws (44), lock washers (9) and diaphragm clamp (43). Also, clean out vent holes in seal plate (25). Check moisture sensor electrodes (18) (if equipped) for damage. Replace by disconnecting wires (16) by removing screws (14). Then remove electrodes (18) from bearing bracket (21). Pipe plugs (31) replace sensor electrodes (18) when pump is supplied without moisture sensors.

Seal - To expose shaft seal (46) for examination, complete above procedure and slide off outboard rotating member (46B). See Figure 7. Remove inboard rotating member (46D), from shaft. Examine all seal parts and especially contact faces. Inspect seal for signs of wear such as uneven wear pattern on stationary members, chips and scratches on either seal face. **DO NOT** interchange seal components, replace the entire shaft seal (46).

F-4.2) Reassembly:

Diaphragm - At reassembly, make sure the bulge and molded-in part number of diaphragm (32) is facing the seal plate (25). With diaphragm (32) in place, lay diaphragm clamp (43) in place on seal plate (25) and insert the four cap screws (44) and lock washers (9) and tighten. Apply pipe thread compound to moisture sensor electrodes (18), if equipped (or pipe plugs 31), and insert in bearing bracket (21). Attach wires (16) with screws (14) to the moisture sensor electrodes (18).

Seal - Clean and oil seal cavities in bearing bracket (21) and seal plate (25). Lightly oil (**DO NOT use grease**) outer surface of inboard stationary member (46E) and outboard stationary member (46A). Press inboard stationary member (46E) firmly into bearing bracket (21) and outboard stationary (46A) into seal plate (25), using a seal pusher (see parts list- seal tool kit), nothing but the seal pusher is to come in contact with seal face (See Figure 9).

Important! - **DO NOT hammer on the seal pusher- it will damage the seal face.**

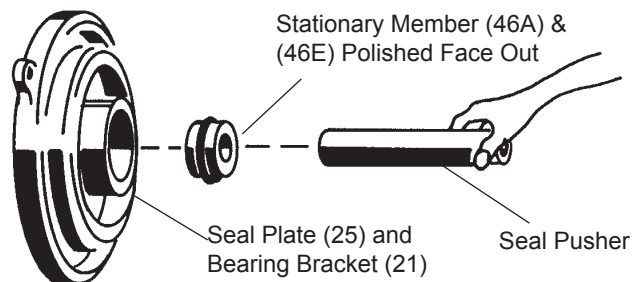

FIGURE 9

Make sure the stationary members are in straight and that the rubber ring is not out of it's groove. Slide a bullet (see parts list-Seal Kit) over motor shaft. Lightly oil (DO NOT use grease) shaft, bullet and inner surface of bellows on rotating member (46D) see Figure 8. With lapped surface facing bearing bracket (21), slide rotating member (46D) over bullet and onto shaft, using seal pusher, until lapped faces of (46D) and (46E) are together (see Figure 8).

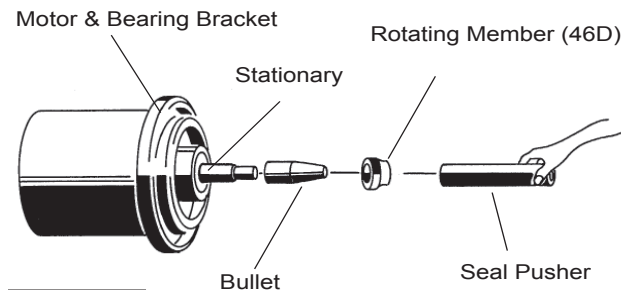

FIGURE 10



Important ! - it is extremely important to keep seal faces clean during assembly. Dirt particles lodged between these faces will cause the seal to leak.

Make sure driving lugs in retainer are matched in rotating member. Place spring (46C) over shaft and in place on rotating member (46E), making sure it is seated in retainer and not cocked or resting on bellows tail. Re-oil shaft and lightly oil inner surface of outboard rotating member (46B) With tail section toward bearing bracket (21), slide rotating member (46B) over bullet onto shaft with seal pusher until retainer engages spring (46C) and spring is compressed slightly. Make sure spring (46C) is properly engaged in both retainers. Insert Square Ring (42) onto bearing bracket (21). Slide seal plate (25) over shaft onto bearing bracket (21), being careful not to damage outboard stationary member (46A) and align holes for socket head cap screws (39). Thread socket head cap screws (39) into bearing bracket (21) torque to 75in-lbs. Assemble impeller and volute per paragraph F-2.2. Fill seal chamber with oil as outlined in paragraph F-1.4.

SECTION: G REPLACEMENT PARTS

G-1 ORDERING REPLACEMENT PARTS:

When ordering replacement parts, ALWAYS furnish the following information:

1. Pump serial number and date code. (Paragraph G-4)
2. Pump model number. (Paragraph G-3)
3. Pump part number. (Paragraph G-2)
4. Part description.
5. Item part number.
6. Quantity required.
7. Shipping instructions.
8. Billing Instructions.

G-2 PART NUMBER:

The part number consists of a six (6) digit number, which appears in the catalog. A one or two letter suffix may follow this number to designate the design configuration. This number is used for ordering and obtaining information.

G-3 MODEL NUMBER:

This designation consists of numbers and letters which represent the discharge size, series, horsepower, motor phase and voltage, speed and pump design. This number is used for ordering and obtaining information.

G-4 SERIAL NUMBER:

The serial number block will consist of a six digit number, which is specific to each pump and may be preceded by a alpha character, which indicates the plant location. This number will also be suffixed with a four digit number, which indicates the date the unit was built (Date Code). **EXAMPLE: A012345 0490.**

Reference the six digit portion (Serial Number) of this number when referring to the product.

CRANE <small>Primo, Ohio</small> PUMPS & SYSTEMS 105500	HP.	Volts	Code	Ph.	Hz.	BARNES ®
	RPM	FLA	Model No.	2		
	Part No.	3		Serial No.	1	
	Impeller Dia.	Max. Liq. Temp.	°C	Ins. Class		
WARNING TO REDUCE RISK OF ELECTRICAL SHOCK DISCONNECT THE PUMP FROM THE POWER SOURCE BEFORE HANDLING OR SERVICING. SEE INSTRUCTION MANUAL FOR PROPER INSTALLATION. SEE WARNING PLATE FOR ADDITIONAL CAUTIONS.						

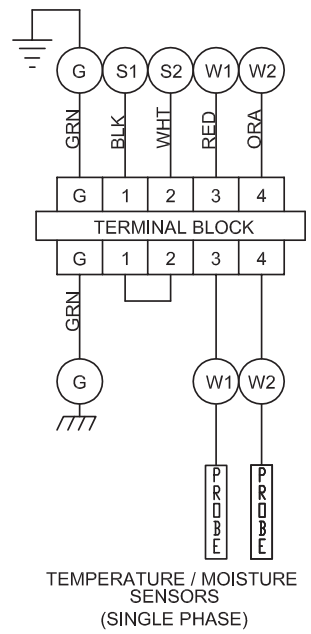
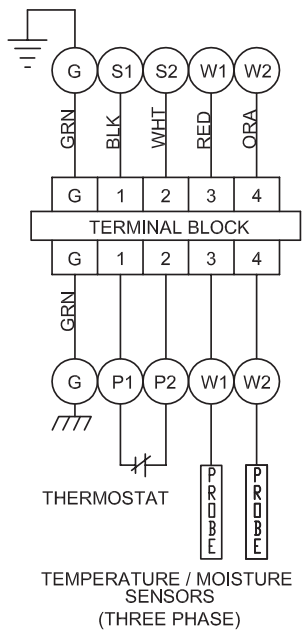
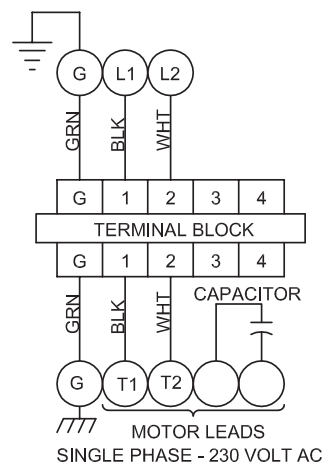
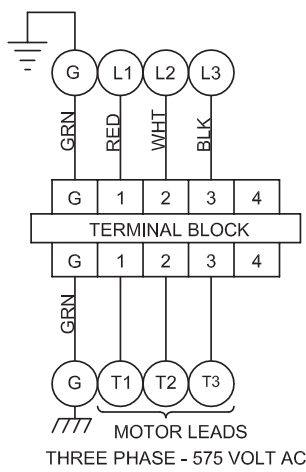
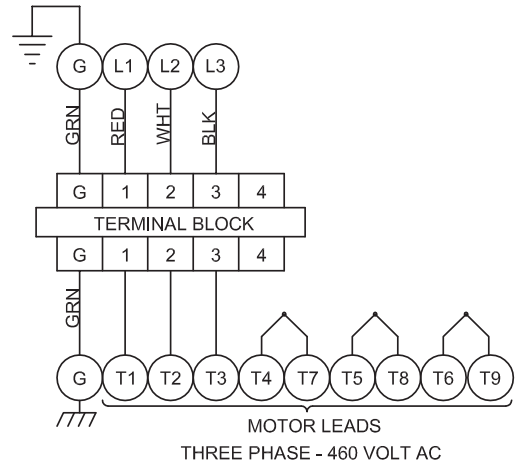
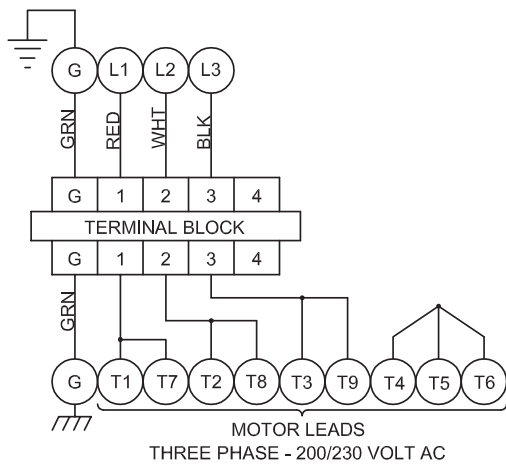

FIGURE 11

TROUBLE SHOOTING

CAUTION ! Always disconnect the pump from the electrical power source before handling.
 If the system fails to operate properly, carefully read instructions and perform maintenance recommendations.
 If operating problems persist, the following chart may be of assistance in identifying and correcting them:
MATCH "CAUSE" NUMBER WITH CORRELATING "CORRECTION" NUMBER.

NOTE: Not all problems and corrections will apply to each pump model.

PROBLEM	CAUSE	CORRECTION
Pump will not run	1. Poor electrical connection, blown fuse, tripped breaker or other interruption of power, improper power supply. 2. Motor or switch inoperative (to isolate cause, go to manual operation of pump). 2a. Float movement restricted. 2b. Switch will not activate pump or is defective. 2c. Defective motor 3. Insufficient liquid level.	1. Check all electrical connections for security. Have electrician measure current in motor leads, if current is within $\pm 20\%$ of locked rotor Amps, impeller is probably locked. If current is 0, overload may be tripped. Remove power, allow pump to cool, then recheck current. 2a. Reposition pump or clean basin as required to provide adequate clearance for float.
Pump will not turn off	2a. Float movement restricted. 2b. Switch will not activate pump or is defective. 4. Excessive inflow or pump not properly sized for application. 9. Pump may be airlocked 14. H-O-A switch on panel is in "HAND" position	2b. Disconnect level control. Set ohmmeter for a low range, such as 100 ohms full scale and connect to level control leads. Actuate level control manually and check to see that ohmmeter shows zero ohms for closed switch and full scale for open switch. (Float Switch). 2c. Check winding insulation (Megger Test) and winding resistance. If check is outside of range, dry and recheck. If still defective, replace per service instructions.
Pump hums but does not run	1. Incorrect voltage 8. Impeller jammed or loose on shaft, worn or damaged, impeller cavity or inlet plugged.	2c. Check winding insulation (Megger Test) and winding resistance. If check is outside of range, dry and recheck. If still defective, replace per service instructions.
Pump delivers insufficient capacity	1. Incorrect voltage. 4. Excessive inflow or pump not properly sized for application. 5. Discharge restricted. 6. Check valve stuck closed or installed backwards. 7. Shut-off valve closed. 8. Impeller jammed or loose on shaft, worn or damaged, impeller cavity or inlet plugged. 9. Pump may be airlocked. 10. Pump running backwards	3. Make sure liquid level is at least equal to suggested turn-on point. 4. Recheck all sizing calculations to determine proper pump size. 5. Check discharge line for restrictions, including ice if line passes through or into cold areas. 6. Remove and examine check valve for proper installation and freedom of operation. 7. Open valve.
Pump cycles too frequently or runs periodically when fixtures are not in use	6. Check valve stuck closed or installed backwards. 11. Fixtures are leaking. 15. Ground water entering basin.	8. Check impeller for freedom of operation, security and condition. Clean impeller and inlet of any obstruction. 9. Loosen union slightly to allow trapped air to escape. Verify that turn-off level of switch is set so that the suction is always flooded. Clean vent hole.
Pump shuts off and turns on independent of switch, (trips thermal overload protector). CAUTION! Pump may start unexpectedly. Disconnect power supply.	1. Incorrect voltage. 4. Excessive inflow or pump not properly sized for application. 8. Impeller jammed, loose on shaft, worn or damaged, impeller cavity or inlet plugged. 12. Excessive water temperature. (internal protection only)	10. Check rotation. If power supply is three phase, reverse any two of three power supply leads to ensure proper impeller rotation.. 11. Repair fixtures as required to eliminate leakage.
Pump operates noisily or vibrates excessively	5. Debris in impeller cavity or broken impeller 10. Pump running backwards 13. Piping attachments to building structure too rigid or too loose. 16. Worn bearings, motor shaft bent.	12. Check pump temperature limits & fluid temperature. 13. Replace portion of discharge pipe with flexible connector. 14. Turn to automatic position. 15. Check for leaks around basin inlet and outlets. 16. Inspect motor shaft runout. Inspect bearings. Replace as necessary.

4SE, 1150 & 1750RPM Pump Series

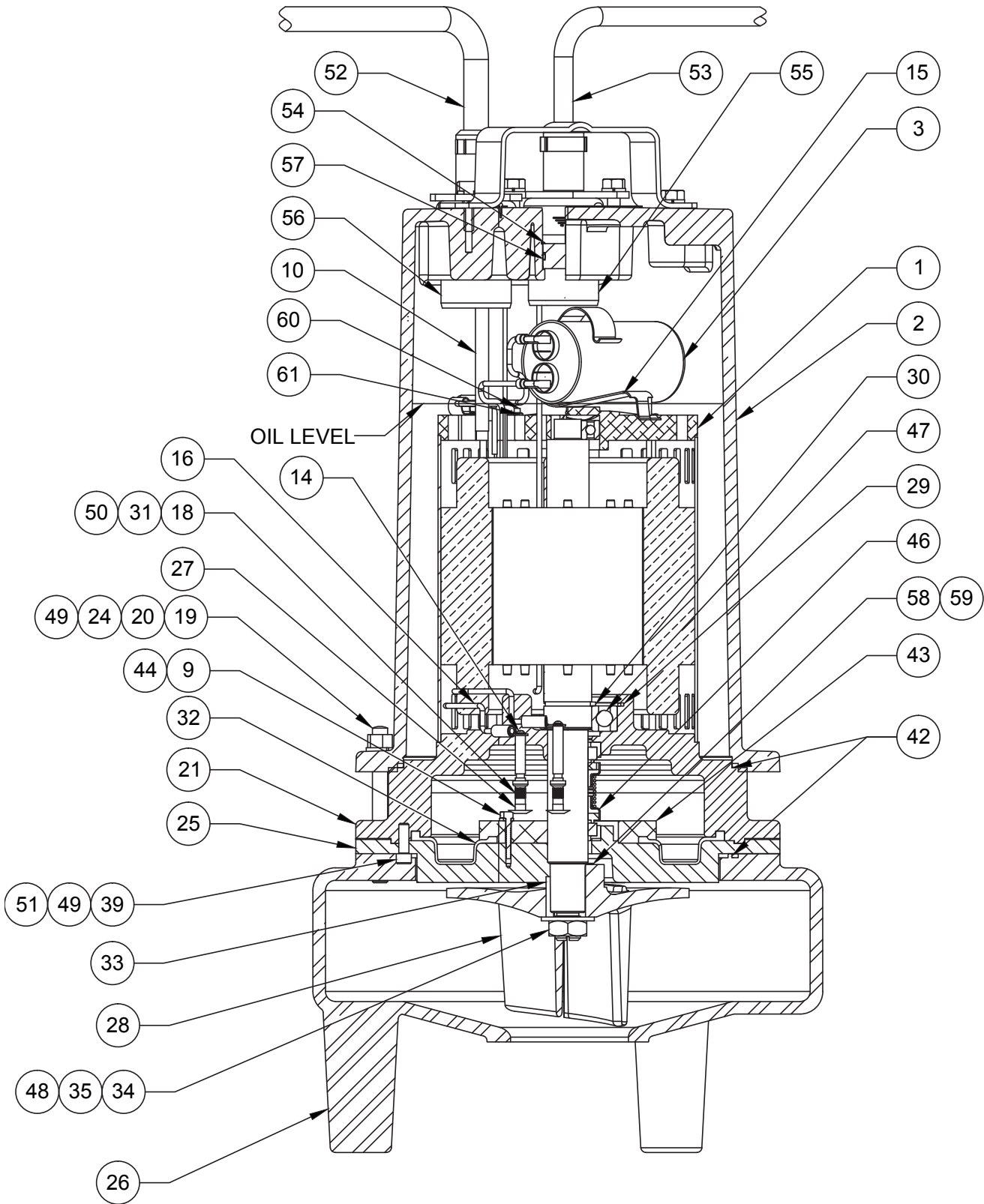

FIGURE 12

4SE, 1150 & 1750RPM Pump Series

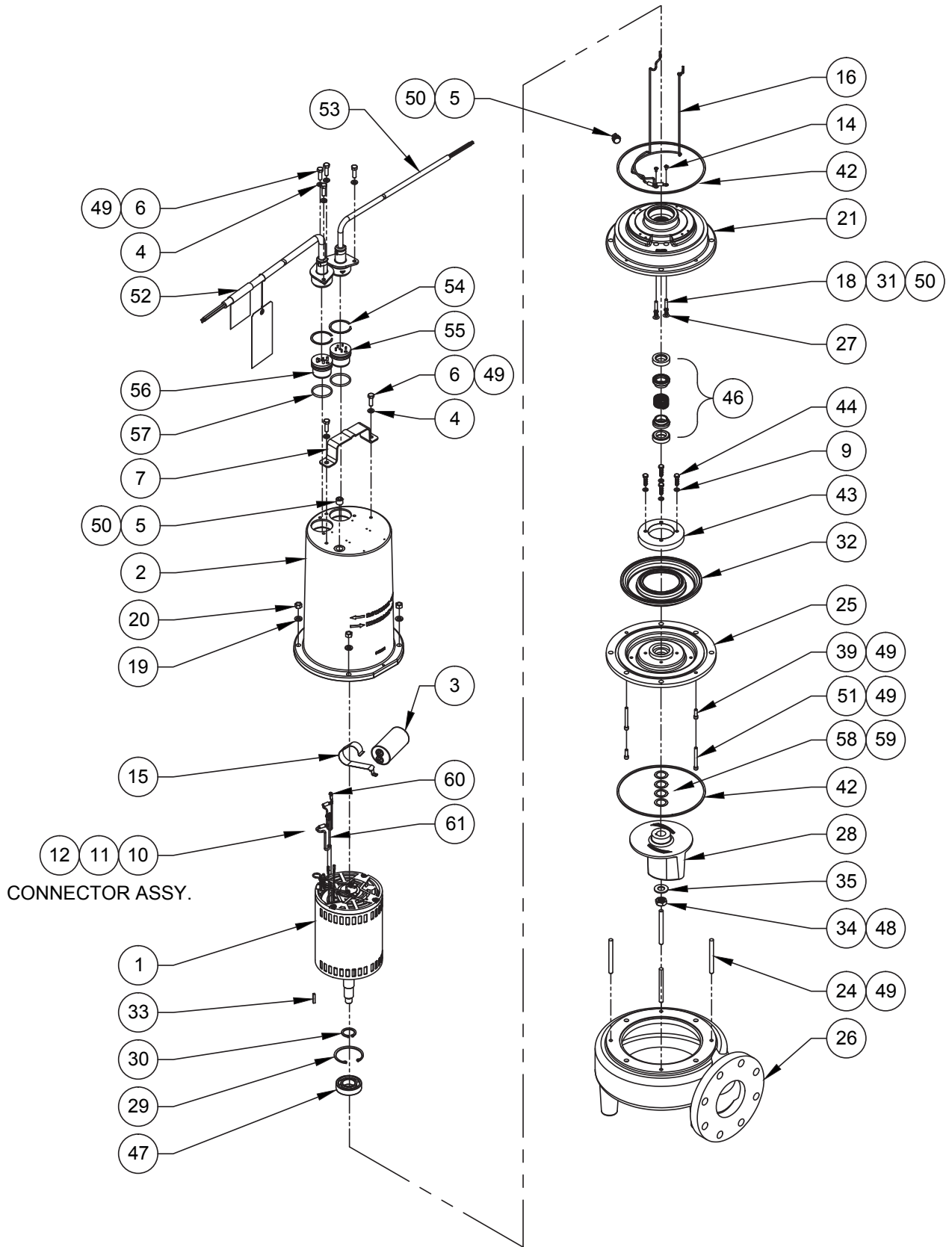

FIGURE 13

4SE, 1150 & 1750RPM Pump Series

PARTS KITS

- Seal Repair Kit.....P/N-130178 (†) 32, 42, 46, 57
 Service Kit.....P/N-130174 (◆) 11, 12, 29, 30, 32, 33, 34, 35, 42, 46, 47, 54, 57
 Seal Tool Kit.....P/N-085736
 Pressure Gauge Kit...P/N-085343

PARTS LIST

ITEM	QTY	PART NO.	DESCRIPTION	NOTES
1	1	082540	Motor, 4SE1926L	230V, 1Phase, 1150RPM
		082541	Motor, 4SE1996L, 4SE1946L	230/460V, 3Phase, 1150RPM
		092864	Motor, 4SE1956L	575V, 3Phase, 1150RPM
		082540	Motor, 4SE2826L	230V, 1Phase, 1150RPM
		082541	Motor, 4SE2896L, 4SE2846L	230/460V, 3Phase, 1150RPM
		096639	Motor, 4SE2856L	575V, 3Phase, 1150RPM
		065900	Motor, 4SE2824L	230V, 1Phase, 1750RPM
		065889	Motor, 4SE2894L, 4SE2844L	230/460V, 3Phase, 1750RPM
		092865	Motor, 4SE2854L	575V, 3Phase, 1750RPM
		065941	Motor, 4SE3724L	230V, 1Phase, 1750RPM
		065889	Motor, 4SE3794L, 4SE3744L	230/460V, 3Phase, 1750RPM
		092866	Motor, 4SE3754L	575V, 3Phase, 1750RPM
		088758	Motor, 4SE5024L	230V, 1Phase, 1750RPM
		088763	Motor, 4SE5094L, 4SE5044L	230/460V, 3Phase, 1750RPM
		088766	Motor, 4SE5054L	575V, 3Phase, 1750RPM
2	1	114492HA	Motor Housing, Double Cords	Power and Sensor Cords (STD)
		114492	Motor Housing, Single cord	Power Cord ONLY (Optional)
3	1	035864	Capacitor - 370V, 35MFD	1.9HP& 2.8HP, 1150RPM 1Phase
		033473	Capacitor - 370V, 40MFD	2.8HP , 1750RPM 1Phase
		036391	Capacitor - 370V, 45MFD	3.7HP & 5HP 1Phase
4	6	026322	Lock washer	5/16" SS
5	2	014270	3/8" NPT Pipe Plug	ZP
6	6	1-156-1	HXHD Cap Screw	5/16-18 x 1" LG, SS
7	1	103503	Handle	SS
9	4	20-13-1	1/4" Lock washer	SS
10	2	625-02117	Fiberglass Sleeve	230V, 3Phase
	1	625-02117	Fiberglass Sleeve	460V, 3Phase, 230V, 1Phase, 575V 3Phase
11	4	105150	Wire Crimp Connector	230V, 3Phase
	3	105150	Wire Crimp Connector	460V, 3Phase
12	3	105149A	Jumper Wire	230V, 3Phase
13	150 oz.	029034	Oil- Motor Housing	
	40 oz.	029034	Oil - Seal Cavity	
14	2	038156	Machine Screw	#6-32 x 3/8" LG, ZP
15	1	133495	Bracket, Cap	1 Phase ONLY
16	1	133403A	Moisture Sensor Wire	Red
	1	133403B	Moisture Sensor Wire	Orange
18	2	066843	Moisture Electrode	
19	4	20-14-1	3/8" Lock washer	SS
20	4	15-23-1	3/8"-16 Hex Nut	SS
21	1	065892	Bearing Bracket	CI
24	4	066103	Stud	3/8-16 x 3-7/8" LG, SS
25	1	065893	Seal Plate	CI
26	1	066743	Volute	CI
27	2	039934	Moisture Electrode Cap Plug	
28	1		Impeller, Cast Iron	1.9HP 1150RPM, 2.8HP & 3.7HP 1750RPM
		058850	7.00" Dia.	(1.9HP STD)
		058850TA	6.88" Dia.	
		058850TB	6.75" Dia.	
		058850TC	6.62" Dia.	
		058850TD	6.50" Dia.	(3.7HP STD)
		058850TE	6.38" Dia.	
		058850TF	6.25" Dia.	
		058850TG	6.12" Dia.	
		058850TH	6.00" Dia.	(2.8HP STD)
		058850TJ	5.88" Dia.	
		058850TK	5.75" Dia.	
		058850TL	5.62" Dia.	
		058850TM	5.50" Dia.	
		058850TN	5.38" Dia.	
		058850TP	5.25" Dia.	

(*) Included with item number 10.

4SE, 1150 & 1750RPM Pump Series

ITEM	QTY	PART NO.	DESCRIPTION	NOTES
		058850TQ	5.12" Dia.	
		058850TR	5.00" Dia.	
		058850TS	4.88" Dia.	
		058850TT	4.75" Dia.	
		058850TU	4.62" Dia.	
		058850TV	4.50" Dia.	
		058850TW	4.38" Dia.	
		058850TX	4.25" Dia.	
		058850TY	4.12" Dia.	
		058850TZ	4.00" Dia.	
28	1		Impeller, Cast Iron	2.8HP 1150RPM & 5.0HP 1750RPM
		088534	7.50" Dia.	(2.8HP STD)
		088534TA	7.38" Dia.	
		088534TB	7.25" Dia.	
		088534TC	7.12" Dia.	
		088534TD	7.00" Dia.	(5.0HP STD)
		088534TE	6.88" Dia.	
		088534TF	6.75" Dia.	
		088534TG	6.62" Dia.	
		088534TH	6.50" Dia.	
		088534TJ	6.38" Dia.	
		088534TK	6.25" Dia.	
		088534TL	6.12" Dia.	
		088534TM	6.00" Dia.	
		088534TN	5.88" Dia.	
		088534TP	5.75" Dia.	
		088534TQ	5.62" Dia.	
		088534TR	5.50" Dia.	
		088534TS	5.38" Dia.	
		088534TT	5.25" Dia.	
29	1	066130	◆ Retaining Ring	
30	1	057882	◆ Retaining Ring	
31	2	003217	1/4" NPT Sq. Pipe Plug	ZP (when Item 18 not used)
32	1	022873	†◆ Diaphragm	Buna-N
33	1	059186	◆ Shaft Key	3/16 Sq x 1" LG, SS
34	1	038132	◆ 5/8-18 Hex Nut	SS
35	1	070320	◆ 5/8" Flat Washer	SS
39	2	036803	SKHD Cap Screw	1/4-20 x 3/4" LG, SS
	2	11-32-1	SKHD Cap Screw	1/4-20 x 1" LG, SS
42	2	033730	†◆ Square Ring	Buna-N
43	1	022879	Diaphragm Clamp Ring	Al
44	4	002204	HXHD Cap Screw	1/4-20 x 1" LG Steel
	4	1-7-1	HXHD Cap Screw	1/4-20 x 1" LG SS
46	1	064434	†◆ Shaft Seal (Both Ends)	Carbon/Ceramic/Buna-N (STD)
		071796	(Pump End)	Tungsten/Tungsten/Buna-N
		071796D	(Both Ends)	Tungsten/Tungsten/Buna-N
47	1	053746	◆ Ball Bearing	
48	A/R	-----	Loctite Adhesive, #RC603	Green
49	A/R	-----	Loctite Adhesive, #242-41	Blue
50	A/R	-----	Loctite PST, #567	White Pipe Sealant
51	2	066192	SKHD Cap Screw	1/4-20 x 2-1/4" LG, SS
52	1	See Table 2	Power Cord Assembly	
53	1	See Table 2	Sensor Cord Assembly	
54	2	105197	◆ Retainer Ring	
55	7	See Table 2	Sensor Cord Terminal Block	
56	1	See Table 2	Power Cord Terminal Block	
57	2	2-31051-224	†◆ O-Ring	Buna-N
58	2	026989	Shim, .005	Use as required
59	2	028120	Shim, .010	Use as required
60	2	016660	Self-Tap Screw	#8-32 x 3/8" LG, SS
61	1	105111	Ground Wire	14 AWG x 8" LG, Grn, 460V/575V 3Phase
	1	105111A	Ground Wire	10 AWG x 8" LG, Grn, 230V 1Phase
	1	105111B	Ground Wire	12 AWG x 8" LG, Grn, 230V 3Phase
	1	111909	Jumper Wire	

4SE, 1150 & 1750RPM Pump Series

TABLE 2 - POWER AND SENSOR CORD SETS				
MODEL NUMBER	30 FT. POWER	50 FT. POWER	100 FT. POWER	TERMINAL BLOCK POWER
4SE1926L	103741XC	103741XF	103741XL	103584
4SE1996L	104742XC	104742XF	104742XL	103583
4SE1946L	103742XC	103742XF	103742XL	103583
4SE1956L	103742XC	103742XF	103742XL	103583
4SE2826L	103498XC	103498XF	103498XL	103760
4SE2896L	103742XC	103742XF	103742XL	103583
4SE2846L	103742XC	103742XF	103742XL	103583
4SE2856L	103742XC	103742XF	103742XL	103583
4SE2824L	103498XC	103498XF	103498XL	103760
4SE2894L	109492XC	109492XF	109492XL	103586
4SE2844L	103742XC	103742XF	103742XL	103583
4SE2854L	103742XC	103742XF	103742XL	103583
4SE3724L	103769XC	103769XF	103769XL	103760
4SE3794L	109492XC	109492XF	109492XL	103586
4SE3744L	103742XC	103742XF	103742XL	103583
4SE3754L	103742XC	103742XF	103742XL	103583
4SE5024L	103769XC	103769XF	103769XL	103760
4SE5094L	103739XC	103739XF	103739XL	103586
4SE5044L	103742XC	103742XF	103742XL	103583
4SE5054L	103742XC	103742XF	103742XL	103583
MODEL NUMBER	30 FT. SENSOR	50 FT. SENSOR	100 FT. SENSOR	TERMINAL BLOCK SENSOR
4SE1926L	113288XC	113288XF	113288XL	113272
4SE1996L	113288XC	113288XF	113288XL	113272
4SE1946L	113288XC	113288XF	113288XL	113272
4SE1956L	113288XC	113288XF	113288XL	113272
4SE2826L	113288XC	113288XF	113288XL	113272
4SE2896L	113288XC	113288XF	113288XL	113272
4SE2846L	113288XC	113288XF	113288XL	113272
4SE2856L	113288XC	113288XF	113288XL	113272
4SE2824L	113288XC	113288XF	113288XL	113272
4SE2894L	113288XC	113288XF	113288XL	113272
4SE2844L	113288XC	113288XF	113288XL	113272
4SE2854L	113288XC	113288XF	113288XL	113272
4SE3724L	113288XC	113288XF	113288XL	113272
4SE3794L	113288XC	113288XF	113288XL	113272
4SE3744L	113288XC	113288XF	113288XL	113272
4SE3754L	113288XC	113288XF	113288XL	113272
4SE5024L	113288XC	113288XF	113288XL	113272
4SE5094L	113288XC	113288XF	113288XL	113272
4SE5044L	113288XC	113288XF	113288XL	113272
4SE5054L	113288XC	113288XF	113288XL	113272

4SE-L 3450RPM Pump Series

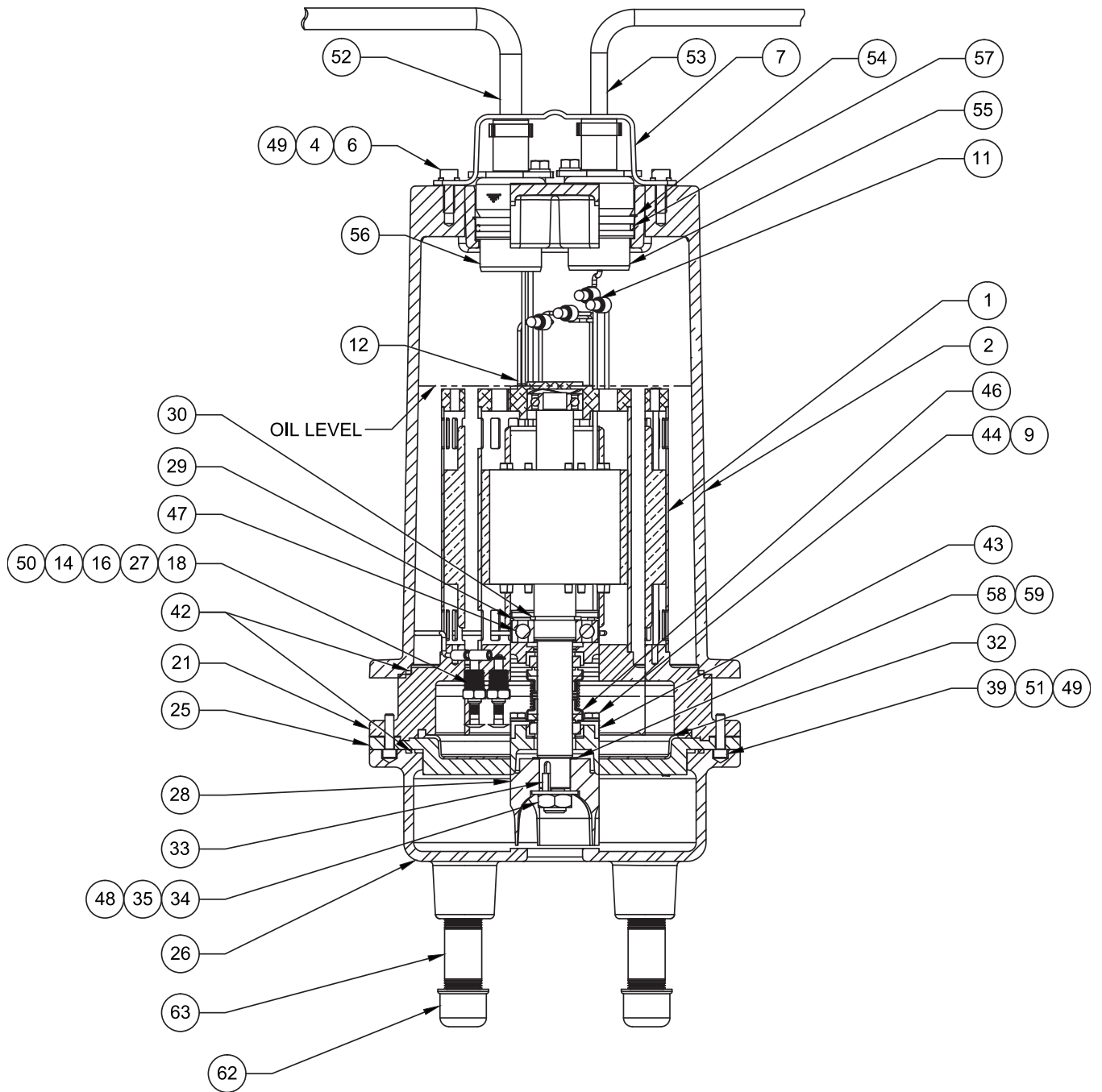

FIGURE 14

4SE-L 3450RPM Pump Series

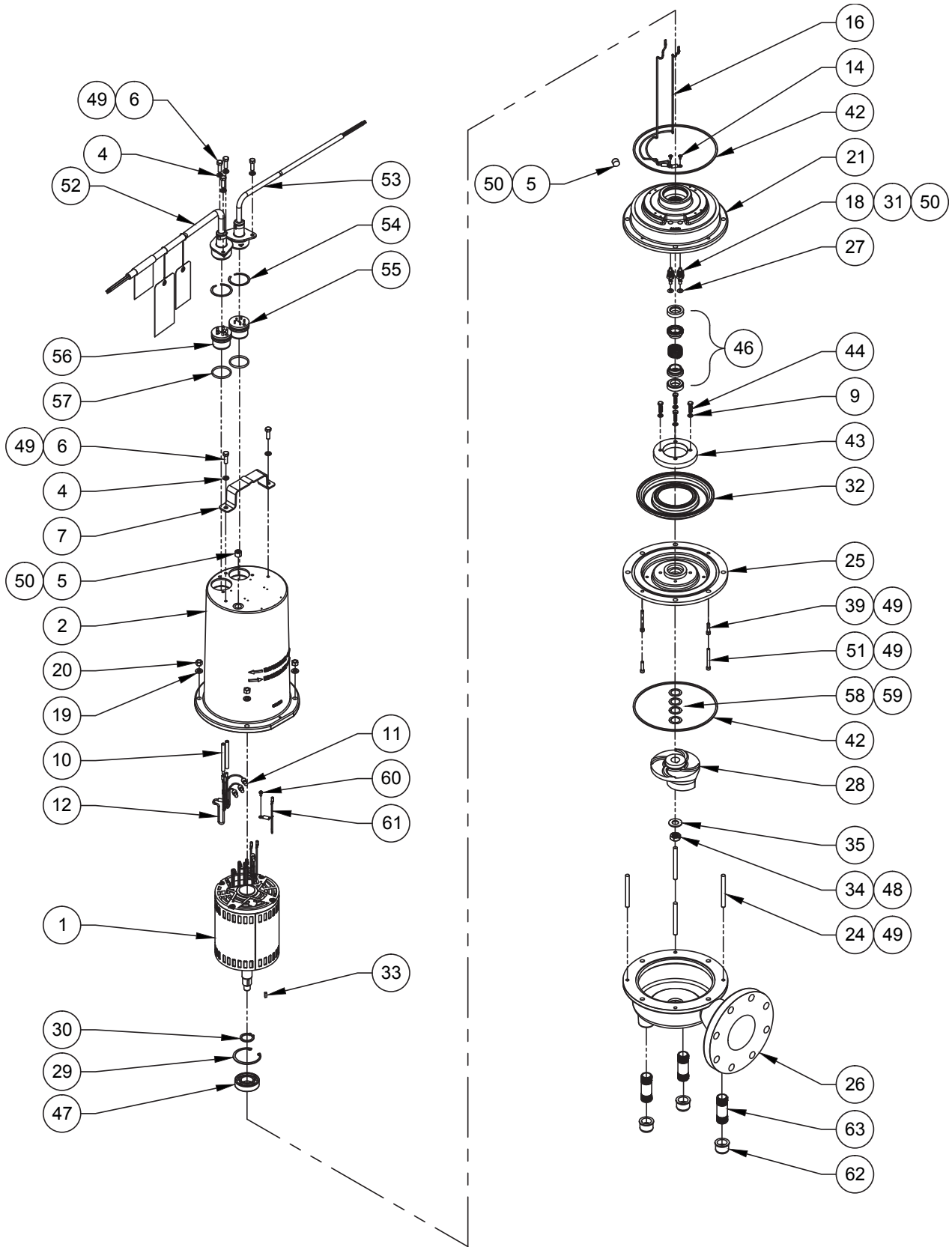

FIGURE 15

4SE-L 3450RPM Pump Series

PARTS KITS

Seal Repair Kits

Double Seal.....P/N - 130178 (†) 32, 42, 46, 57

Service Kits

Double Seal.....P/N - 130174 (♦) 11, 12, 29, 30, 32, 33, 34, 35, 42, 46, 47, 54, 57

Seal Tool Kit.....P/N-085736

Pressure Gauge Kit.....P/N-085343

PARTS LIST

ITEM	QTY	PART NO.	DESCRIPTION	NOTES
1	1	088754	Motor, 4SE5032L, 4SE5042L	230/460V, 3Phase, 3450RPM
		088756	Motor, 4SE5052L	575V, 3Phase, 3450RPM
2	1	114492HA	Motor Housing, Double Cords	Power and Sensor Cord (STD)
	1	114492	Motor Housing, Single Cord	Power Cord ONLY (Optional)
4	6	026322	5/16" Lock Washer	SS
5	2	014270	3/8" NPT Pipe Plug	ZP
6	6	1-156-1	HXHD Cap Screw	5/16-18 x 1" LG, SS
7	1	103503	Handle	SS
9	4	20-13-1	1/4" Lock Washer	SS
10	2	625-02117	Fiberglass Sleeve	230V, 3Phase
	1	625-02117	Fiberglass Sleeve	460V, 3Phase, 575V, 3Phase
11	4	105150	Wire Crimp Connector	230V, 3Phase
	3	105150	♦ Wire Crimp Connector	460/575V, 3Phase
12	3	105149A	♦ Jumper Wire	230V, 3 Phase
13	150 oz.	029034	Oil- Motor Housing	
	40 oz.	029034	Oil - Seal Cavity	
14	2	038156	Machine Screw	#6-32 x 3/8" LG, ZP
16	1	133403B	Moisture Sensor Wire	Red
	1	133403A	Moisture Sensor Wire	Orange
18	2	066843	Moisture Electrode	
19	4	20-14-1	3/8" Lock Washer	SS
20	4	15-23-1	3/8-16 Hex Nut	SS
21	1	065892	Bearing Bracket	CI
24	4	066103	Stud	3/8-16 x 3-7/8" LG, SS
25	1	065893	Seal Plate	CI
26	1	066744	Volute	CI
27	2	039934	Moisture Electrode Cap Plug	
28	1	088545	Impeller, Cast Iron	
		088545TA	5.00" Dia. (STD)	
		088545TB	4.88" Dia.	
		088545TC	4.75" Dia.	
		088545TD	4.63" Dia.	
		088545TE	4.50" Dia.	
		088545TE	4.38" Dia.	
		088545TF	4.25" Dia.	
		088545TG	4.13" Dia.	
		088545TH	4.00" Dia.	
		088545TJ	3.88" Dia.	
		088545TK	3.75" Dia.	
		088545TL	3.63" Dia.	
		088545TM	3.50" Dia.	
29	1	066130	♦ Retaining Ring	
30	1	057882	♦ Retaining Ring	
31	2	003217	1/4" NPT Sq. Pipe Plug	ZP (When Item 18 Not Used)
32	1	022873	†♦ Diaphragm	Buna-N
33	1	057554	♦ Shaft Key	3/16 Sq x .585" LG, SS
34	1	038132	♦ 5/8-18Hex Nut	SS
35	1	070320	♦ 5/8" Flat Washer	SS

(*) Included with item number 10.

4SE-L 3450RPM Pump Series PARTS LIST

ITEM	QTY	PART NO.	DESCRIPTION	NOTES
39	2	11-32-1	SKHD Cap Screw	1/4-20 x 1" LG, SS
42	2	033730	†♦ Square Ring	Buna-N
43	1	022879	Diaphragm Clamp Ring	AL
44	4	1-7-1	Cap Screw	1/4-20 x 1" LG, SS
46	1	064434 071796 071796D 064434SD	†♦ Shaft Seal (Both Ends) (Pump End) (Both Ends) (Pump End)	Carbon/Ceramic/Buna-N (STD) Tungsten/Tungsten/Buna-N Tungsten/Tungsten/Buna-N Silicone Carbide/Silicone Carbide/Buna-N
47	1	053746	♦ Ball Bearing	
48	A/R	-----	Loctite Adhesive, #RC603	Green
49	A/R	-----	Loctite Adhesive, #242-41	Blue
50	A/R	-----	Loctite PST, #567	White Pipe Sealant
51	2	066192	SKHD Cap Screw	1/4-20 x 2-1/4" LG, SS
52	1	See Table 3	Power Cord Assembly	
53	1	See Table 3	Sensor Cord Assembly	
54	2	105197	♦ Retainer Ring	
55		See Table 3	Sensor Cord Terminal Block	
56		See Table 3	Power Cord Terminal Block	
57	2	2-31051-224	†♦ O-Ring	Buna-N
58	2	026989	Shim, .005	Use as required
59	2	028120	Shim, .010	Use as required
60	2	016660	Self Tap Screw	#8-32 x 3/8" LG, SS
61	1	105111	Ground Wire	Sensor Cable Assy. Ground
	1	105111	Ground Wire	460V, 3 Phase, 575V, 3 Phase
	1	105111B	Ground Wire	230V, 3 Phase
62	3	003479	3/4" NPT Pipe Cap	
63	3	005808	Pipe Nipple	3/4" NPT x 3" Galvanized
	1	111909	Jumper Wire	

TABLE 3 - POWER AND SENSOR CORD SETS

MODEL NUMBER	30 FT. POWER	50 FT. POWER	100 FT. POWER	TERMINAL BLOCK POWER
4SE5032L	109492XC	109492XF	109492XL	103586
4SE5042L	103742XC	103742XF	103742XL	103583
4SE5052L	103742XC	103742XF	103742XL	103583
MODEL NUMBER	30 FT. SENSORS	50 FT. SENSORS	100 FT. SENSORS	TERMINAL BLOCK POWER
4SE5032L	113288XC	113288XF	113288XL	113272
4SE5042L	113288XC	113288XF	113288XL	113272
4SE5052L	113288XC	113288XF	113288XL	113272

BARNES®



burks®

WEINMAN®

DEMING®

PROSSER®

Limited 24 Month Warranty

Crane Pumps & Systems warrants that products of our manufacture will be free of defects in material and workmanship under normal use and service for twenty-four (24) months after manufacture date, when installed and maintained in accordance with our instructions. This warranty gives you specific legal rights, and there may also be other rights which vary from state to state. In the event the product is covered by the Federal Consumer Product Warranties Law (1) the duration of any implied warranties associated with the product by virtue of said law is limited to the same duration as stated herein, (2) this warranty is a LIMITED WARRANTY, and (3) no claims of any nature whatsoever shall be made against us, until the ultimate consumer, his successor, or assigns, notifies us in writing of the defect, and delivers the product and/or defective part(s) freight prepaid to our factory or nearest authorized service station. Some states do not allow limitations on how long an implied warranty lasts, so the above limitation may not apply. **THE SOLE AND EXCLUSIVE REMEDY FOR BREACH OF ANY AND ALL WARRANTIES WITH RESPECT TO ANY PRODUCT SHALL BE TO REPLACE OR REPAIR AT OUR ELECTION, F.O.B. POINT OF MANUFACTURE OR AUTHORIZED REPAIR STATION, SUCH PRODUCTS AND/OR PARTS AS PROVEN DEFECTIVE. THERE SHALL BE NO FURTHER LIABILITY, WHETHER BASED ON WARRANTY, NEGLIGENCE OR OTHERWISE.** Unless expressly stated otherwise, guarantees in the nature of performance specifications furnished in addition to the foregoing material and workmanship warranties on a product manufactured by us, if any, are subject to laboratory tests corrected for field performance. Any additional guarantees, in the nature of performance specifications must be in writing and such writing must be signed by our authorized representative. Due to inaccuracies in field testing if a conflict arises between the results of field testing conducted by or for user, and laboratory tests corrected for field performance, the latter shall control. **RECOMMENDATIONS FOR SPECIAL APPLICATIONS OR THOSE RESULTING FROM SYSTEMS ANALYSES AND EVALUATIONS WE CONDUCT WILL BE BASED ON OUR BEST AVAILABLE EXPERIENCE AND PUBLISHED INDUSTRY INFORMATION. SUCH RECOMMENDATIONS DO NOT CONSTITUTE A WARRANTY OF SATISFACTORY PERFORMANCE AND NO SUCH WARRANTY IS GIVEN.**

This warranty shall not apply when damage is caused by (a) improper installation, (b) improper voltage (c) lightning (d) excessive sand or other abrasive material (e) scale or corrosion build-up due to excessive chemical content. Any modification of the original equipment will also void the warranty. We will not be responsible for loss, damage or labor cost due to interruption of service caused by defective parts. Neither will we accept charges incurred by others without our prior written approval.

This warranty is void if our inspection reveals the product was used in a manner inconsistent with normal industry practice and/or our specific recommendations. The purchaser is responsible for communication of all necessary information regarding the application and use of the product. **UNDER NO CIRCUMSTANCES WILL WE BE RESPONSIBLE FOR ANY OTHER DIRECT OR CONSEQUENTIAL DAMAGES, INCLUDING BUT NOT LIMITED TO TRAVEL EXPENSES, RENTED EQUIPMENT, OUTSIDE CONTRACTOR FEES, UNAUTHORIZED REPAIR SHOP EXPENSES, LOST PROFITS, LOST INCOME, LABOR CHARGES, DELAYS IN PRODUCTION, IDLE PRODUCTION, WHICH DAMAGES ARE CAUSED BY ANY DEFECTS IN MATERIAL AND/OR WORKMANSHIP AND/OR DAMAGE OR DELAYS IN SHIPMENT. THIS WARRANTY IS EXPRESSLY IN LIEU OF ANY OTHER EXPRESS OR IMPLIED WARRANTY, INCLUDING ANY WARRANTY OF MERCHANTABILITY OR FITNESS FOR A PARTICULAR PURPOSE.**

No rights extended under this warranty shall be assigned to any other person, whether by operation of law or otherwise, without our prior written approval.

CRANE

PUMPS & SYSTEMS

A Crane Co. Company

420 Third Street
Piqua, Ohio 45356
(937) 778-8947
Fax (937) 773-7157
www.cranepumps.com

83 West Drive
Brampton, Ont. Canada L6T 2J6
(905) 457-6223
Fax (905) 457-2650

**IMPORTANT!
WARRANTY REGISTRATION**

Your product is covered by the enclosed Warranty.
To complete the Warranty Registration Form go to:

<http://www.cranepumps.com/ProductRegistration/>

If you have a claim under the provision of the warranty, contact your local
Crane Pumps & Systems, Inc. Distributor.

RETURNED GOODS

**RETURN OF MERCHANDISE REQUIRES A "RETURNED GOODS AUTHORIZATION".
CONTACT YOUR LOCAL CRANE PUMPS & SYSTEMS, INC. DISTRIBUTOR.**



**Products Returned Must Be Cleaned, Sanitized,
Or Decontaminated As Necessary Prior To Shipment,
To Insure That Employees Will Not Be Exposed To Health
Hazards In Handling Said Material. All Applicable Laws
And Regulations Shall Apply.**