

SHUR-Switch[™]

If you want a pump that lasts,
buy one with a **BETTER** switch

Available Models:

- **SU33 - 1/3 hp**



- Float is housed in a shroud to guard against obstruction and wedging.
- **Magnets** activate switch as float rises and falls.
- Tested to over 1 million cycles.

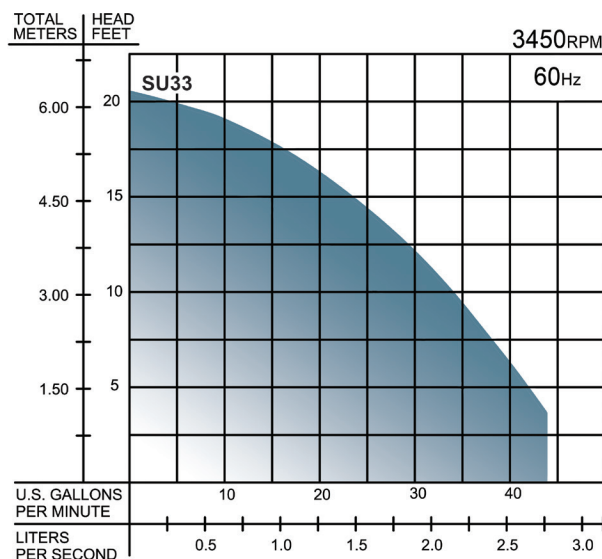

U.S. Patent: 8,167,578

SHUR-Switch™ Series

Sump pumps often fail because the float switch is wedged against the basin wall or by debris.
 Failure is not an option with the Barnes SHUR-Switch™ sump pump.
 The SHUR-Switch™ pump provides innovative and high quality features at a competitive price.

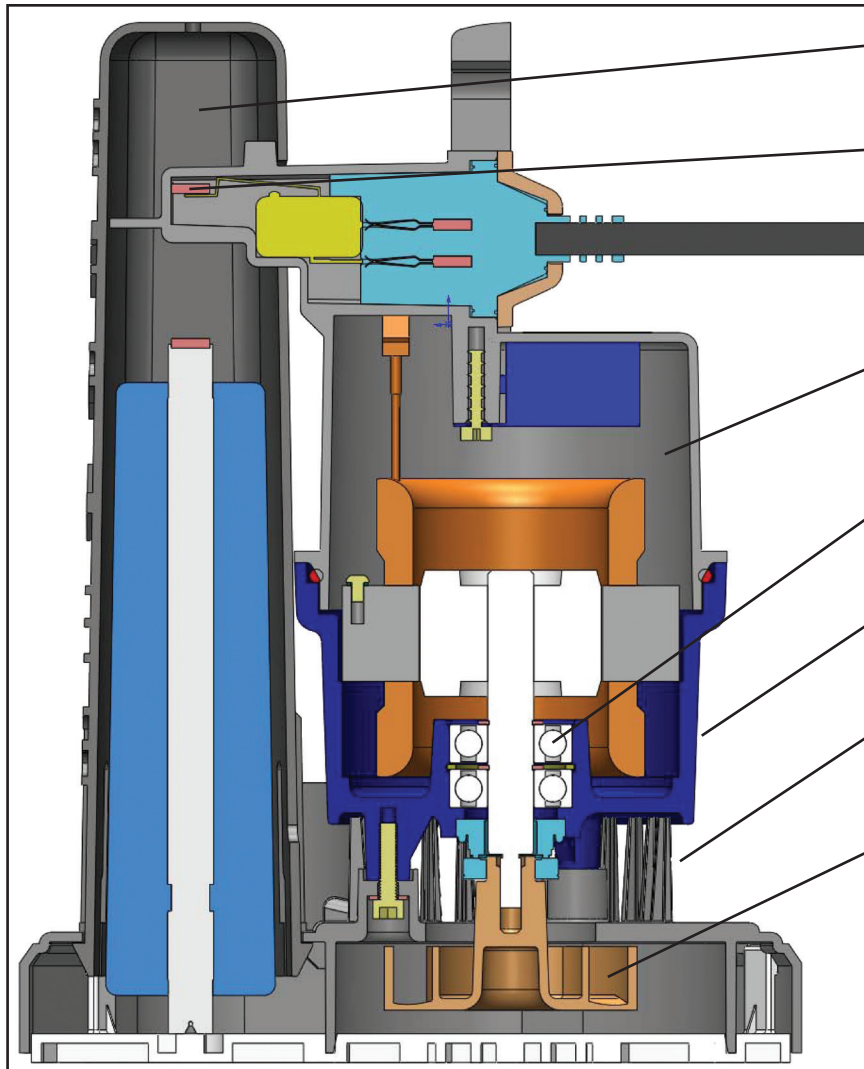

Patented, magnetic float switch is protected for maximum durability.

High strength, rare earth magnets provide outstanding activation capability with a totally sealed switch.

Permanent Split Capacitor motor draws less amps.

Oil lubricated bearings provide quieter running and longer life.

Cast iron motor housing provides excellent motor heat dissipation.

Built-in strainer prevents large solids from clogging the impeller.

Top-suction impeller eliminates air lock issues.

Model	SU33
HP	1/3
Voltage	120V 1ph
RPM	3450
Discharge	1½"
Solids	3/16"
Max. GPM	42
Max. Head	20'
Cord Length	9'



A Crane Co. Company

PUMPS & SYSTEMS

Crane Pumps & Systems
 420 Third Street
 Piqua, Ohio 45356
 (937) 778-8947
 Fax (937) 773-7157
 www.cranepumps.com

Crane Pumps & Systems Canada
 83 West Drive
 Brampton, Ont. Canada L6T 2J6
 (905) 457-6223
 Fax (905) 457-2650

© 2017 Crane Pumps & Systems, Inc.
 A Crane Co. Company
 Printed in U.S.A.
 BPPSU - Rev. E (1/17)

brands you trust.

BARNES®

burks®

DEMING®

WEINMAN®



PROSSER®