



**Barmesa<sup>®</sup>**  
**Pumps**

**Installation, Operation &  
Maintenance Manual**  
Submersible Solids  
Handling Pumps

## **SW series**

### **4SWL / M / H**

15-100 HP @ 1750 RPM

7.5-40 HP @ 1150 RPM

### **6SWL / M / H**

15-125 HP @ 1750 RPM

7.5-40 HP @ 1150 RPM

### **8SWL**

15-125 HP @ 1750 RPM

7.5-40 HP @ 1150 RPM



**IMPORTANT! - Read all instructions in this manual before operating or servicing a pump.**

Before installation, read the following instructions carefully. Failure to follow instruction and safety information could cause serious bodily injury, death and/or property damage. Each Barmesa product is carefully inspected to insure proper performance. Closely following these instructions will eliminate potential operating problems, assuring years of trouble-free service.

**⚠ DANGER** "Danger" indicates an imminently hazardous situation which, if not avoided, WILL result in death or serious injury.

**⚠ WARNING** "Warning" indicates an imminently hazardous situation which, if not avoided, MAY result in death or serious injury.

**⚠ CAUTION** "Caution" indicates a potentially hazardous situation which, if not avoided, MAY result in minor or moderate injury.

**IMPORTANT! - Barmesa Pumps is not responsible for losses, injury or death resulting from failure to observe these safety precautions, misuse, abuse or misapplication of pumps or equipment.**



**ALL RETURNED PRODUCTS MUST BE CLEANED, SANITIZED, OR DECONTAMINATED PRIOR TO SHIPMENT, TO INSURE EMPLOYEES WILL NOT BE EXPOSED TO HEALTH HAZARDS IN HANDLING SAID MATERIAL. ALL APPLICABLE LAWS AND REGULATIONS SHALL APPLY.**

**⚠ WARNING** Installation, wiring, and junction connections must be in accordance with the National Electric Code and all applicable state and local codes. Requirements may vary depending on usage and location.

**⚠ WARNING** Installation and servicing is to be conducted by qualified personnel only.



Keep clear of suction and discharge openings. Do not insert fingers in pump with power connected; the rotating cutter and/or impeller can cause serious injury.



Always wear eye protection when working on pumps. Do not wear loose clothing that may become entangled in moving parts.



**⚠ DANGER** Pumps build up heat and pressure during operation. Allow time for pumps to cool before handling or servicing the pump or any accessory items associated with or near the pump.



**⚠ DANGER** This pump is not intended for use in swimming pools or water installations where there is human contact with pumped fluid.



**⚠ DANGER** Risk of electric shock. To reduce risk of electric shock, always disconnect pump from power source before handling any aspect of the pumping system. **Lock out power and tag.**

**⚠ WARNING** Do not use these pumps in water over 104° F. Do not exceed manufacturers recommended maximum performance, as this could cause the motor to overheat.



**⚠ DANGER** Do not lift, carry or hang pump by the electrical cables. Damage to the electrical cables can cause shock, burns or death. **Never** handle connected power cords with wet hands. Use appropriate lifting device.

**⚠ WARNING** Ground Fault Circuit Interrupter (GFCI) to be used with plug-in type power cord.

**⚠ WARNING** Sump and sewage pumps often handle materials which could cause illness or disease. Wear adequate protective clothing when working on a used pump or piping. Never enter a basin after it has been used.



**⚠ DANGER** Failure to permanently ground the pump, motor and controls before connecting to power can cause shock, burns or death.



**⚠ DANGER** These pumps are not to be installed in locations classified as hazardous in accordance with the National Electric Code, ANSI/NFPA 70.

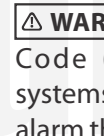

**⚠ WARNING** The Uniform Plumbing Code (UPC) states that sewage systems shall have an audio and visual alarm that signals a malfunction of the systems, that are required to reduce the potential for property damage.

**IMPORTANT! - Prior to installation, record Model Number, Serial, Amps, Voltage, Phase and HP from pump name plate for the future reference. Also record the Voltage and Current Readings at Startup:**

3 Phase Models	
Amps L1-2:	Volts L1-2:
Amps L2-3:	Volts L2-3:
Amps L3-1:	Volts L3-1:

Model Number: \_\_\_\_\_

Serial: \_\_\_\_\_

PHASE: \_\_\_\_\_ HP: \_\_\_\_\_

<b>DISCHARGE:</b>	4", 6" & 8" 125lb, flange horizontal.
<b>SPHERICAL SLD HNDLG:</b>	3"
<b>LIQUID TEMPERATURE:</b>	104 °F (40 °C) max.
<b>VOLUTE:</b>	Cast iron ASTM A-48 class 30
<b>MOTOR HOUSING:</b>	Cast iron ASTM A-48 class 30
<b>SEAL PLATE:</b>	Cast iron ASTM A-48 class 30
<b>IMPELLER:</b>	Enclosed mono vane for 4SW and dual vane for 6SW and 8SW, with pump-out vanes on back side. Dynamically balanced. Ductile iron ASTM A-536, 65-45-12.
<b>SHAFT:</b>	416 series stainless steel
<b>HARDWARE:</b>	300 series stainless steel
<b>O-RINGS:</b>	Buna-N
<b>LIFTING BAILS:</b>	300 series stainless steel
<b>MAX. SUBMERGENCE:</b>	66 ft (20 m)
<b>PAINT:</b>	Epoxy
<b>MECHANICAL SEAL:</b>	Double, tandem, in oil filled reservoir. Inboard rotating faces, carbon; stationary faces, ceramic. Outboard rotating and stationary faces, silicon carbide. Buna-N elastomer and 300 series stainless steel hardware.
<b>CORD ENTRY:</b>	40 ft cord, epoxy sealed housing, with secondary pressure grommet for sealing and strain relief.
<b>UPPER BEARING:</b>	Ball, single row, oil lubricated, for radial load.
<b>LOWER BEARING:</b>	Ball, single row, oil lubricated, for radial and thrust loads.
<b>MOTOR:</b>	NEMA three phase 208/230 & 460 V, premium efficiency, oil-filled, squirrel cage induction, inverted duty rated. Class H insulation. Requires overload protection in control panel.
<b>MOISTURE SENSOR:</b>	Normally open (N/O), requires relay and panel.
<b>TEMPERATURE SENSOR:</b>	Normally closed (N/C), to be wired in series with control circuit.
<b>OPTIONAL EQUIPMENT:</b>	Slide rail coupling, leg kit and seal material.

► 4SWL

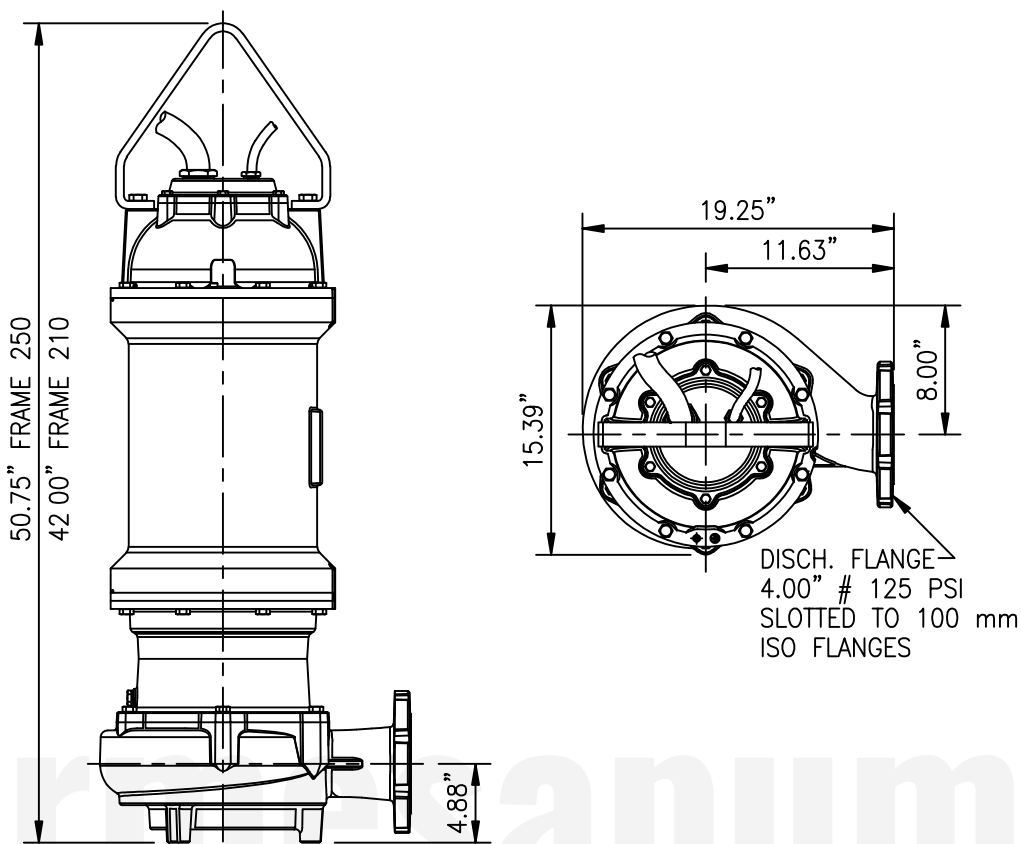

MODEL	PART No.	HP	PH	VOLTS	RPM (nom)	NEMA START CODE	FULL LOAD AMPS	SF	AMPS SF	FRAME	POWER CORD SIZE	WEIGHT (lb)
4SWL15034DS	62172001	15	3	208/230	1750	E	39/37.2	1.15	45/42.8	210	10/4	492
4SWL15044DS	62172002			460			18.6		21.4			
4SWL20034DS	62172003	20	3	208/230	1750	J	52.8/48	1.15	60.7/55	250	8/4	602
4SWL20044DS	62172004			460			24.1		27.3			
4SWL25034DS	62172005	25	3	208/230	1750	G	65/59	1.15	74.8/67.8	250	8/4	620
4SWL25044DS	62172006			460			29.5		34			
4SWL30034DS	62172007	30	3	208/230	1750	E	93.4/82.3	1.15	107/94	250	8/4	640
4SWL30044DS	62172008			F		46.7	53					
4SWL40044DS	62172010	40	3	460	1750	E	48	1.15	55.2	250	8/4	670
4SWL7536DS	62172011	7.5	3	208/230	1150	J	20	1.15	25/23	250	8/4	568
4SWL7546DS	62172012			460			10		11.5			
4SWL10036DS	62172013	10	3	208/230	1150	E	29/27	1.15	37/33	250	10/4	585
4SWL10046DS	62172014			460			13.5		18.4			
4SWL15036DS	62172015	15	3	208/230	1150	H	47.43	1.15	54/49.4	250	10/4	610
4SWL15046DS	62172016			460			21.5		24.7			

Note: Seal moisture and temperature sensor cord in all models size 18/5.

► 4SWM

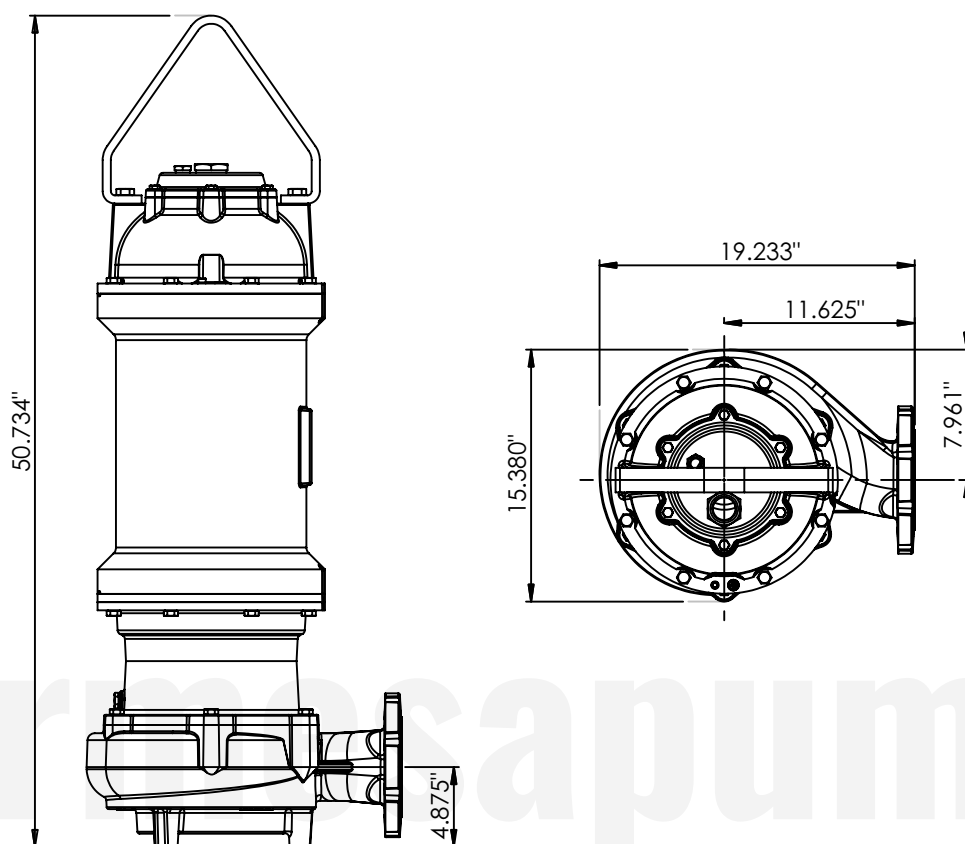

barrowapumps

MODEL	PART No.	HP	PH	VOLTS	RPM (nom)	NEMA START CODE	FULL LOAD AMPS	SF	AMPS SF	FRAME	POWER CORD SIZE	WEIGHT (lb)
4SWM20034DS	62172019	20	3	208/230	1750	J	52.8/48	1.15	60.7/55	250	8/4	615
4SWM20044DS	62172020			460			24.1		27.3			
4SWM25034DS	62172021	25	3	208/230	1750	G	65/59	1.15	74.8/67.8	250	8/4	633
4SWM25044DS	62172022			460			29.5		34			
4SWM30034DS	62172023	30	3	208/230	1750	E	93.4/82.3	1.15	107/94	250	8/4	653
4SWM30044DS	62172024			460		F	46.7		53			
4SWM40044DS	62172025	40	3	460	1750	E	48	1.15	55.2	250	8/4	683
4SWM50044DS	62172026	50	3	460	1750	F	65	1.15	74.8	320	2/3	760

Note: Seal moisture and temperature sensor cord in all models size 18/5.

► 4SWH

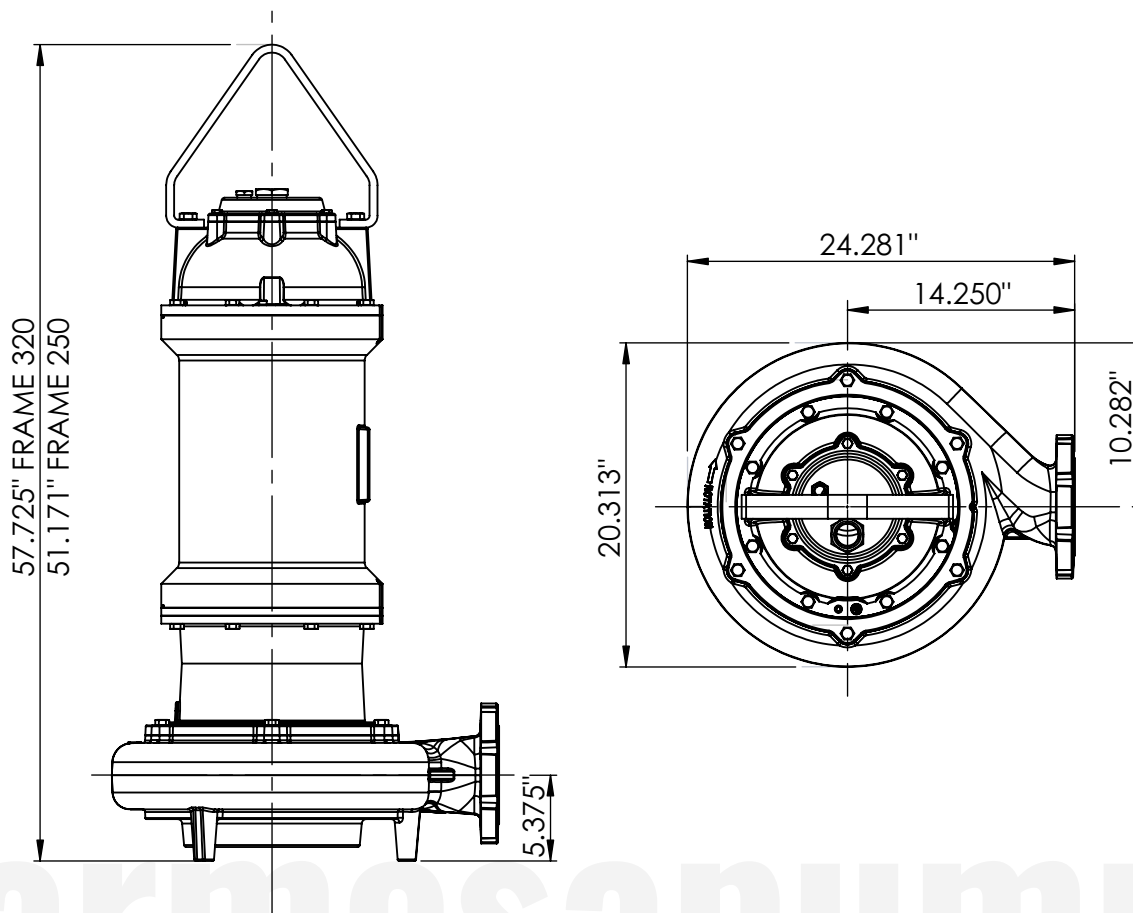

MODEL	PART No.	HP	PH	VOLTS	RPM (nom)	NEMA START CODE	FULL LOAD AMPS	SF	AMPS SF	FRAME	POWER CORD SIZE	WEIGHT (lb)
4SWH20034DS	62172029	20	3	208/230	1750	J	52.8/48	1.15	60.7/55	250	8/4	615
4SWH20044DS	62172030			460			24.1		27.3			
4SWH25034DS	62172031	25	3	208/230	1750	G	65/59	1.15	74.8/67.8	250	8/4	633
4SWH25044DS	62172032			460			29.5		34			
4SWH30034DS	62172033	30	3	208/230	1750	E	93.4/82.3	1.15	107/94	250	8/4	653
4SWH30044DS	62172034			F		46.7	53					
4SWH40044DS	62172035	40	3	460	1750	E	48	1.15	55.2	250	8/4	683
4SWH50044DS	62172036	50	3	460	1750	F	65	1.15	74.8	320	2/3	760
4SWH60044DS	62172037	60	3	460	1750	E	76.6	1.15	88.1	320	2/3	782
4SWH75044DS	62172038	75	3	460	1750	G	105	1.15	120.7	320	2/3	806
4SWH100044DS	62172039	100	3	460	1750	E	132.5	1.15	152.4	400	2/3	927
4SWH10036DS	62172042	10	3	208/230	1150	E	29/27	1.15	37/33	250	10/4	598
4SWH10046DS	62172043			460			13.5		18.4			
4SWH15036DS	62172044	15	3	208/230	1150	H	47.43	1.15	54/49.4	250	10/4	623
4SWH15046DS	62172045			460			21.5		24.7			
4SWH20036DS	62172046	20	3	208/230	1150	E	44.3/49.2	1.15	51/56.6	250	8/4	642
4SWH20046DS	62172047			460			24.6		28.3			
4SWH25036DS	62172048	25	3	208/230	1150	G	72.9/68.7	1.15	83.8/66.6	320	8/4	719
4SWH25046DS	62172049			460			36.4		41.8			
4SWH30036DS	62172050	30	3	208/230	1150	E	88/80	1.15	101/92	320	8/4	740
4SWH30046DS	62172051			460			44		50.6			
4SWH40046DS	62172052	40	3	460	1150	E	107	1.15	123	320	8/4	762

Note: Seal moisture and temperature sensor cord in all models size 18/5.

► 6SWL

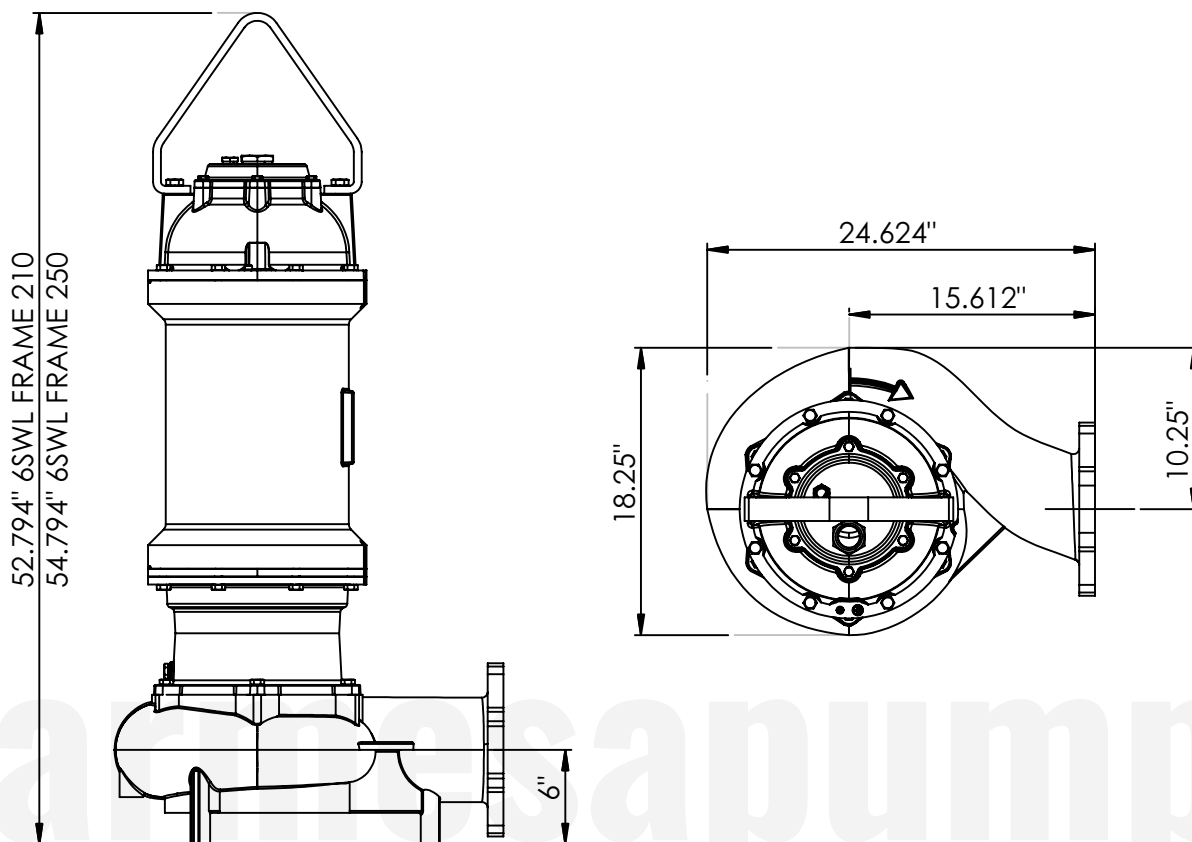

MODEL	PART No.	HP	PH	VOLTS	RPM (nom)	NEMA START CODE	FULL LOAD AMPS	SF	AMPS SF	FRAME	POWER CORD SIZE	WEIGHT (lb)
6SWL15034DS	62172101	15	3	208/230	1750	E	39/37.2	1.15	45/42.8	210	10/4	692
6SWL15044DS	62172102			460			18.6		21.4			
6SWL20034DS	62172103	20	3	208/230	1750	J	52.8/48	1.15	60.7/55	250	8/4	823
6SWL20044DS	62172104			460			24.1		27.3			
6SWL25034DS	62172105	25	3	208/230	1750	G	65/59	1.15	74.8/67.8	250	8/4	847
6SWL25044DS	62172106			460			29.5		34			
6SWL7536DS	62172107	7.5	3	208/230	1150	J	22/20	1.15	23	250	10/4	790
6SWL7546DS	62172108			460			10		11.5			
6SWL10036DS	62172109	10	3	208/230	1150	E	29/27	1.15	37/33	250	10/4	800
6SWL10046DS	62172110			460			13.5		18.4			

Note: Seal moisture and temperature sensor cord in all models size 18/5.

► 6SWM

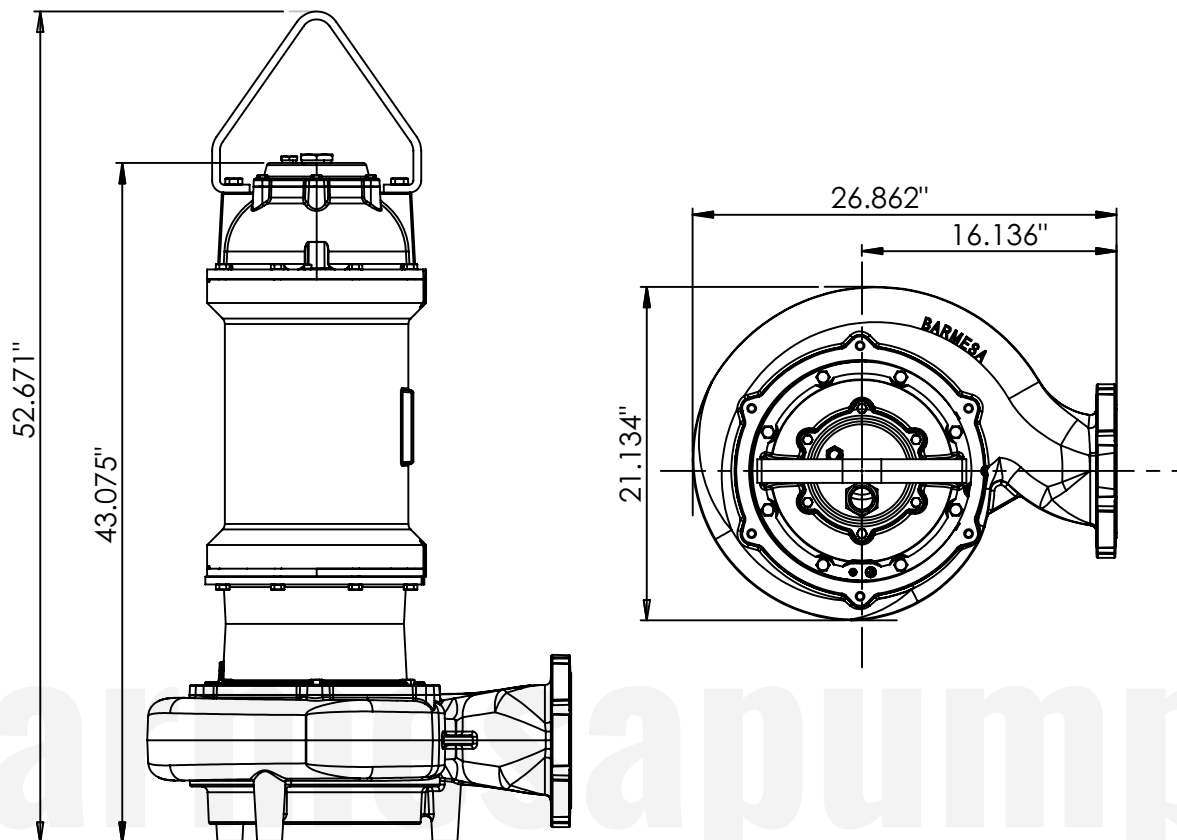

MODEL	PART No.	HP	PH	VOLTS	RPM (nom)	NEMA START CODE	FULL LOAD AMPS	SF	AMPS SF	FRAME	POWER CORD SIZE	WEIGHT (lb)
6SWM25034DS	62172111	25	3	208/230	1750	G	65/59	1.15	74.8/67.8	250	8/4	985
6SWM25044DS	62172112			460			29.5		34			
6SWM30044DS	62172114	30	3	460	1750	F	46.7	1.15	53	250	8/4	1016
6SWM40044DS	62172116	40	3	460	1750	E	48	1.15	55.2	250	2/3	1046
6SWM50044DS	62172118	50	3	460	1750	F	65	1.15	74.8	320	2/3	1123
6SWM10036DS	62172119	10	3	208/230	1150	F	29/27	1.15	1.1	250	12/4	815
6SWM10046DS	62172120			460			13.5		15.5			
6SWM15036DS	62172121	15	3	208/230	1150	H	43	1.15	49.4	250	12/4	840
6SWM15046DS	62172122			460			21.5		24.7			

Note: Seal moisture and temperature sensor cord in all models size 18/5.



► 6SWH

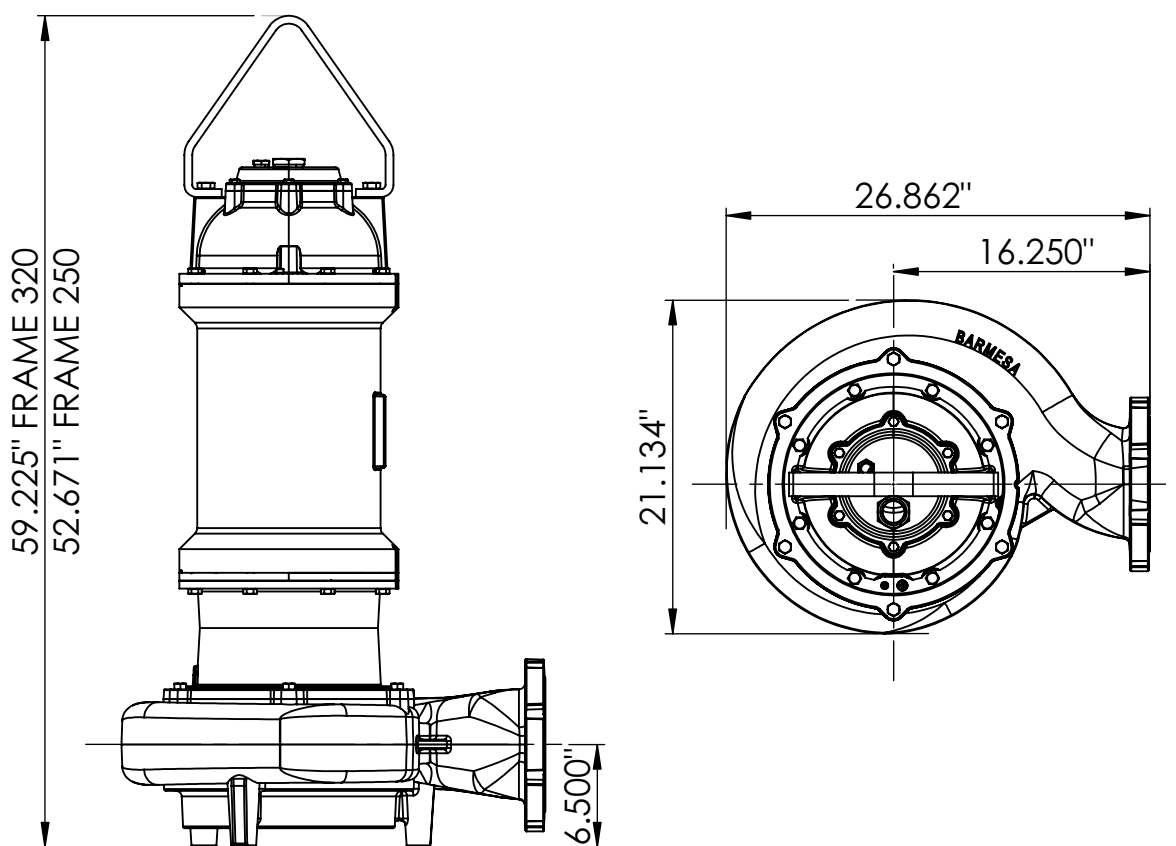

MODEL	PART No.	HP	PH	VOLTS	RPM (nom)	NEMA START CODE	FULL LOAD AMPS	SF	AMPS SF	FRAME	POWER CORD SIZE	WEIGHT (lb)
6SWH25034DS	62172123	25	3	208/230	1750	G	65/59	1.15	74.8/67.8	250	2/3	985
6SWH25044DS	62172124			460			29.5		34			
6SWH30034DS	62172125	30	3	208/230	1750	E	93.4/82.3	1.15	107/94	250	2/3	1016
6SWH30044DS	62172126			460		F	46.7		53			
6SWH40044DS	62172127	40	3	460	1750	E	48	1.15	55.2	250	2/3	1046
6SWH50044DS	62172128	50	3	460	1750	F	65	1.15	74.8	320	2/3	1123
6SWH60044DS	62172129	60	3	460	1750	E	76.6	1.15	88.1	320	2/3	1156
6SWH75044DS	62172130	75	3	460	1750	G	105	1.15	120.7	320	2/3	1191
6SWH100044DS	62172131	100	3	460	1750	E	132.5	1.15	152.4	400	2/3	1226
6SWH125044DS	62172132	125	3	460	1750	F	164.3	1.15	189	400	2/3	1263
6SWH7536DS	62172133	7.5	3	208/230	1150	J	22/20	1.15	23	250	10/4	798
6SWH7546DS	62172134			460			10		11.5			
6SWH10036DS	62172135	10	3	208/230	1150	E	29/27	1.15	37/33	250	10/4	815
6SWH10046DS	62172136			460			13.5		18.4			
6SWH15036DS	62172137	15	3	208/230	1150	H	47/43	1.15	54/49.4	250	2/3	840
6SWH15046DS	62172138			460			21.5		24.7			
6SWH20036DS	62172139	20	3	208/230	1150	E	44.3/49.2	1.15	51/56.6	250	2/3	865
6SWH20046DS	62172140			460			24.6		28.3			
6SWH25036DS	62172141	25	3	208/230	1150	G	72.9/68.7	1.15	83.8/66.6	320	2/3	955
6SWH25046DS	62172142			460			36.4		41.80			
6SWH30036DS	62172143	30	3	208/230	1150	E	88/80	1.15	101/92	320	2/3	983
6SWH30046DS	62172144			460			44		50.6			
6SWH40046DS	62172146	40	3	460	1150	E	107	1.15	123	320	2/3	1013

Note: Seal moisture and temperature sensor cord in all models size 18/5.

► 8SWL

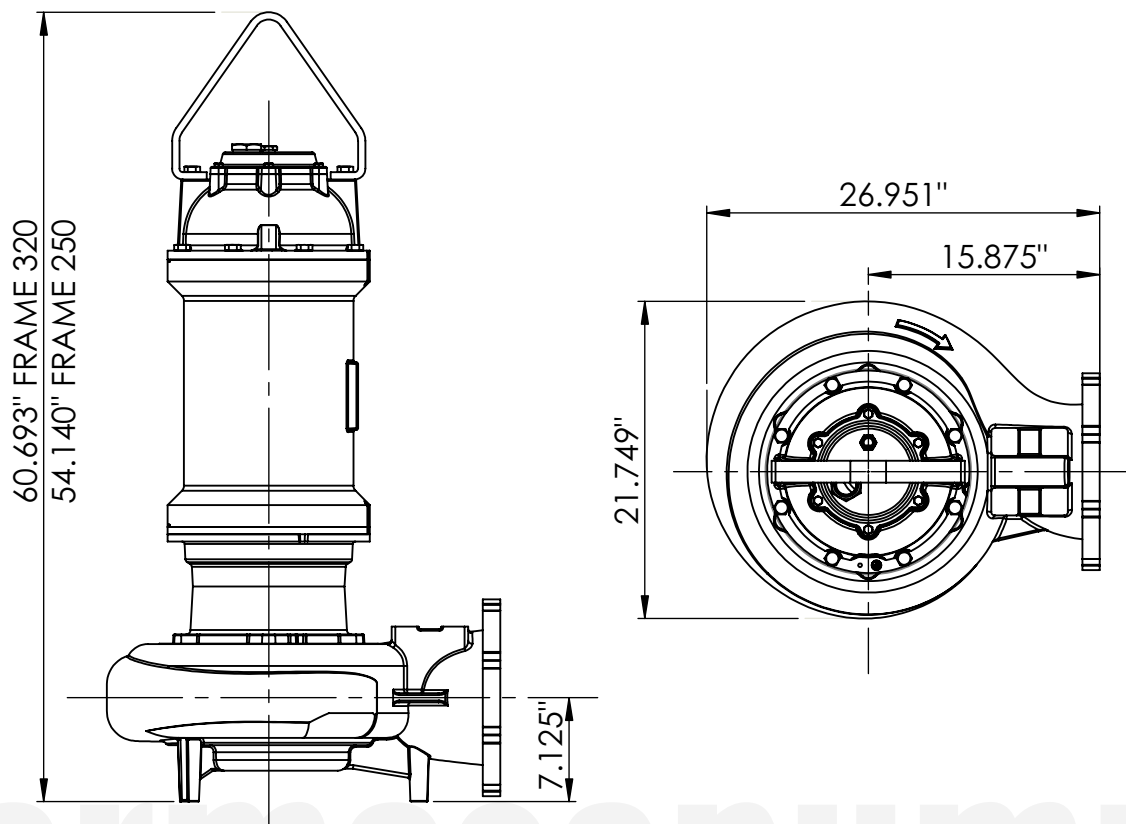

MODEL	PART No.	HP	PH	VOLTS	RPM (nom)	NEMA START CODE	FULL LOAD AMPS	SF	AMPS SF	FRAME	POWER CORD SIZE	WEIGHT (lb)
8SWL25034DS	62172201	25	3	208/230	1750	G	65/59	1.15	74.8/67.8	250	2/3	-
8SWL25044DS	62172202			460			29.5		34			-
8SWL30034DS	62172203	30	3	208/230	1750	E	93.4/82.3	1.15	107/94	250	2/3	-
8SWL30044DS	62172204			460			46.7		53			-
8SWL40044DS	62172205	40	3	460	1750	E	48	1.15	55.2	250	2/3	-
8SWL50044DS	62172206	50	3	460	1750	F	65	1.15	74.8	320	2/3	-
8SWL60044DS	62172207	60	3	460	1750	E	76.6	1.15	88.1	320	2/3	-
8SWL75044DS	62172208	75	3	460	1750	G	105	1.15	120.7	320	2/3	-
8SWL100044DS	62172209	100	3	460	1750	E	132.5	1.15	152.4	400	2/3	-
8SWL7536DS	62172210	7.5	3	208/230	1150	J	22/20	1.15	23	250	10/4	-
8SWL7546DS	62172211			460			10		11.5			-
8SWL10036DS	62172212	10	3	208/230	1150	E	29/27	1.15	37/33	250	10/4	-
8SWL10046DS	62172213			460			13.5		18.4			-
8SWL15036DS	62172214	15	3	208/230	1150	H	47/43	1.15	54/49.4	250	2/3	-
8SWL15046DS	62172215			460			21.5		24.7			-
8SWL20036DS	62172216	20	3	208/230	1150	E	44.3/49.2	1.15	51/56.6	250	2/3	-
8SWL20046DS	62172217			460			24.6		28.3			-
8SWL25036DS	62172218	25	3	208/230	1150	G	72.9/68.7	1.15	83.8/66.6	320	2/3	-
8SWL25046DS	62172219			460			36.4		41.8			-

Note: Seal moisture and temperature sensor cord in all models size 18/5.

## ► Receiving inspection

Upon receiving the pump, it should be inspected for damage or shortages. If damage has occurred, file a claim immediately with the company that delivered the pump. If the manual is removed from the packaging, do not lose or misplace.

## ► Storage

Any product that is stored for a period longer than six (6) months from the date of purchase should be bench tested prior to installation. A bench test consists of, checking the impeller to assure it is free turning and a run test to assure the motor (and switch if provided) operate properly.

## ► Controls

Manual models require a separate approved pump control device or panel for automatic operation. Be sure the electrical specification of the control selected properly match the electrical specifications of the pump.

## ► Submergence

The pump should always be operated in the submerged condition. The minimum sump liquid level should never be less than above the pump's volute (See Figure 1).

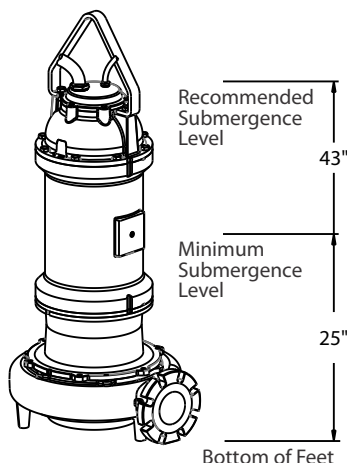

Figure 1

## ► Installation

These pumps are recommended for use in a sump, basin or lift station. The sump, basin or lift station shall be sealed and vented in accordance with local plumbing codes. **This pump is designed to pump sewage, effluent or wastewater, non-explosive and non-corrosive liquids and shall NOT be installed in locations classified as hazardous in accordance with the National Electrical Code (NEC) ANSI/NFPA 70 or Canadian Electric Code (CEC).** The pump should never be installed in a trench, ditch, or hole with a dirt bottom. The legs will sink into the dirt and the suction will become plugged.

The installation should be at a sufficient depth to ensure that all plumbing is below the frost line. If this is not feasible, remove the check valve and size the basin to accommodate the additional backflow volume.

Pumps are most commonly installed in simplex or duplex stations or basins with a slide rail system (Barmesa SRC), which allows the pump(s) to be installed or removed without requiring personnel to enter the station, or resting on the basin floor.

## ► Discharge Piping

Discharge piping should be as short as possible and sized no smaller than the pump discharge. **Do not reduce the discharge pipe size below that which is provided on the pump.** Both a check valve and a shut-off valve are recommended for each pump. The check valve is used to prevent backflow into the sump. The shut-off valve is used to manually stop system low during pump servicing.

## ► Liquid Level Controls

The level control(s) should be mounted on the discharge piping, a cable rack or float pole. The level control should have adequate clearance so it cannot hang up in its swing and that the pump is completely submerged when the level control is in the "Off" mode. By adjusting the cord tether the control level can be changed. One cycle of operation should be observed, so that any potential problems can be corrected.

It is recommended that the level control float should be set to insure that the liquid in the sump never drops below the top of the motor housing or a minimum level of 10 inches above the basin floor.

## ► Electrical Connections

### Power cable:

The power cable mounted to the pump must not be modified in any way except for shortening to a specific application. Any splice between the pump and the control panel must be made in accordance with the electric codes. It is recommended that a junction box, if used, be mounted outside the sump or be of at a minimum NEMA 4 construction if located within the wet well. **DO NOT USE THE POWER CABLE TO LIFT PUMP.**

Always rely upon a Certified Electrician for installation.

### Overload Protection:

**Single Phase** - The stator in-winding overload protector used is referred to as an inherent overheating protector and operates on the combined effect of temperature and current. This means that the overload protector will trip out and shut the pump off if the windings become too hot, or the load current passing through them becomes too high.

**IMPORTANT!** - The overload will then automatically reset and start the pump up after the motor cools to a safe temperature. In the event of an overload, the source of this condition should be determined and corrected immediately.

**⚠ WARNING DO NOT ALLOW THE PUMP TO CYCLE OR RUN IF AN OVERLOAD CONDITION OCCURS.**

**Three Phase** - The Normally Closed (N/C) thermal sensor is embedded in the motor windings and will detect excessive heat in the event an overload condition occurs. The thermal sensor will trip when the windings become too hot and will automatically reset when the pump motor cools to a safe temperature. It is recommended that the thermal sensor be connected in series to an alarm device to alert the operator of an overload condition, and/or the motor starter coil to stop the pump. In the event of an overload, the source of this condition should be determined and repaired.

**⚠ WARNING DO NOT ALLOW THE PUMP TO CYCLE OR RUN IF AN OVERLOAD CONDITION OCCURS.**

**Moisture Sensors** - A normally open (N/O) sensor rated of 1 watt @330K ohms, 500 volt, is installed in the pump seal chamber which will detect any moisture present. It is recommended that this detector be wired in series to an alarm device or motor starter coil to alert the operator that a moisture detect has occurred. In the event of a moisture detect, check the individual moisture sensor probe leads for continuity, ( $\infty$  resistance = no moisture) and the junction box/control box for moisture content.

These situations may induce a false signal in the moisture detecting circuit. If none of the above test prove conclusive, the pump(s) should be pulled and the source of the failure repaired. **IF A MOISTURE DETECT HAS OCCURRED MAINTENANCE SHOULD BE PERFORMED AS SOON AS POSSIBLE!**

If current through the temperature sensor exceeds the values listed, an intermediate control circuit relay must be used to reduce the current or the sensor will not work properly.

TEMPERATURE SENSOR ELECTRICAL RATINGS		
Volts	Continuous Amperes	Inrush Amperes
110-120	3.00	30.0
220-240	1.50	15.0
440-480	0.75	7.5
600	0.60	6.0

**Wire Size:**

If longer power cable is required consult a qualified electrician for proper wire size.

**► Pre-Operation**

**1. Check Voltage and Phase** - Compare the voltage and phase information stamped on the pump name plate.

**2. Check Pump Rotation** - Improper motor rotation can result in poor pump performance and can damage the motor and/or pump. Check rotation on three phase units by momentarily applying power and observe the "kickback".

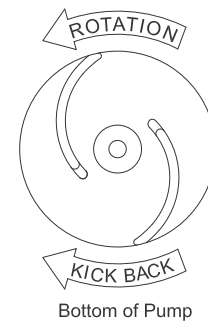

Kickback should always be in a counter-clockwise direction as viewed from motor end or opposite to impeller rotation. Impeller rotation is counter-clockwise as viewed from bottom of pump.

**3. Name Plate** - Record the information from the pump name plate to drawing in front of manual for future reference.

**4. Insulation Test** - An insulation (megger) test should be performed on the motor. Before the pump is put into service. The resistance values (ohms) as well as the voltage (volts) and current (amps) should be recorded.

**5. Pump-Down Test** - Be sure pump has been properly wired, lowered into the basin, sump or lift station, check the system by filling with liquid and allowing the pump to operate through its pumping cycle. The time needed to empty the system, or pump-down time along with the volume of water, should be recorded.

**► Maintenance**

No lubrication or maintenance is required. Perform the following checks when pump is removed from operation or when pump performance deteriorates:

- a) Inspect motor chamber for oil level and contamination.
- b) Inspect impeller and body for excessive build-up or clogging.
- c) Inspect motor, bearings and shaft seal for wear or leakage.

► **Servicing**

**Cooling Oil** - Anytime the pump is removed from operation, the cooling oil in the motor housing should be checked visually for oil level and contamination. To check oil, set unit upright. Remove cap screws, lift conduit box assembly from motor housing, **Do Not** disconnect wiring from motor leads. With a flashlight, visually inspect the oil in the motor housing to make sure it is clean and clear, light amber in color and free from suspended particles. Milky white oil indicates the presence of water. Oil level should be just above the motor when pump is in vertical position.

**Seal Chamber** - Drain oil from seal chamber by placing pump on its side and remove pipe plug. If the oil is found to contain considerable water or other contamination, the shaft seal should be inspected and replaced if required.

**Oil Testing**

- Drain oil into a clean, dry container placing pump on its side, remove cap screws, lift conduit box assembly from motor housing. In separate container drain seal chamber by removing plug.
- Check oil for contamination using an oil tester with a range to 30 kV breakdown.
- If oil is found to be clean and uncontaminated (measuring above 15 kV breakdown), refill the housing.

- If oil is found to be dirty or contaminated (or measures below 15 kV breakdown), the pump must be carefully inspected for leaks at the shaft seal, conduit box, o-rings, pipe plug and pressure valve, before refilling with oil.

After leak is repaired, dispose of old oil properly, and refill with new oil.

**Oil Replacement** - Set unit upright and refill with new cooling oil as per table. Fill to just above motor as an air space must remain in the top of the housing to compensate for oil expansion. Reassemble the o-ring and conduit box to motor housing. Apply thread locking compound to cap screws and place into holes and torque to 15 ft/lbs.



**DO NOT** overfill oil. Overfilling of housing with oil can create excessive and dangerous hydraulic pressure which can destroy the pump and create a hazard.

Overfilling oil voids warranty.

**Oil Replacement:**

**Seal Chamber** - Refill chamber completely full with new cooling oil or reuse the uncontaminated oil.

Cooling Oil Recommended Supplier/Grade	
BP	Enerpar SE100
Conoco	Pale Parafin 22
Mobile	D.T.E. Oil Light
Shell Canada	Transformer-10
Texaco	Diala-Oil-AX

► **Disassembly**

**Impeller and Volute** - Disconnect power. Remove hex nuts and vertically lift motor housing and seal plate assembly from volute. Clean out volute if necessary. Inspect gasket and replace if cut or damaged. Clean and examine impeller, for pitting or wear and replace if required. To remove impeller, remove cap screw and washer. With a wheel puller, pull impeller straight of shaft and remove square key.

**Moisture Probes** - Drain oil from seal chamber, if not already done. Remove cap screws and lifting handle. Set unit upside down on blocks to avoid damaging cables. Remove socket head cap screws and lift seal plate, with seal's stationary, vertically from bearing housing, **do not** damage seal. Check moisture sensor probes for damage, replace by removing screws and disconnecting wires. Then remove probes from bearing housing.

**Shaft Seal** - Remove outboard rotating member of seal, spring and inboard rotating member from shaft. Examine all seal parts.

Inspect seal for signs of uneven wear pattern on stationary members, chips and scratches on either seal face. **DO NOT interchange seal components, replace the entire shaft seal.** If replacing seal, remove stationary by prying out with flat screwdriver.

**Motor and Bearings** - Remove volute, impeller, seal plate and seal as previously stated and drain oil from motor housing. Position unit upright, using blocks to avoid resting unit on shaft. Remove cap screws o-ring and conduit box assembly from motor housing.



Note connections and then remove cable lead wires from motor lead wires and moisture and temperature sensor wires from control cable by removing connectors. Remove cap screws and vertically lift the motor housing from bearing housing. Replace square ring if damaged or cut. Remove the upper motor bolts and lift upper end bell from motor. Remove wave washer. Remove upper bearing with a wheel puller if damaged or worn.

Vertically lift stator from rotor/shaft. Inspect windings for shorts and resistance. Test the temperature sensors by checking for continuity between the black and white wires. If defective contact factory or motor service station. Pull motor rotor/shaft with bearing from bearing housing. Remove bearing with a wheel puller if worn or damaged. If rotor or stator windings are defective, replace the complete motor.



**IMPORTANT!** - All parts must be clean before reassembly.

### ► Reassembly

**Bearings** - Replace bearings, being careful not to damage the rotor or shaft. If equipped, fill notch should face the rotor core for both upper and lower bearings.

Apply adhesive compound to the shaft and press bearing onto shaft, position squarely onto the shaft applying force to the inner race of bearing only, until bearing seats on shoulder of the shaft. In the same manner, assemble upper bearing to shaft.

**Motor** - Slide rotor with bearing into bearing housing until bearing seats on the bottom. Position motor housing and stator into pilot, install wave washers in upper end bell.

**IMPORTANT! Special wave washers in upper motor housing are required to compensate for shaft expansion. These washers must be properly reinstalled to give the required constant down force on the motor shaft.**

Position upper motor end bell aligning holes and thread cap screws into bearing housing and torque to 16 ft/lbs. Place all motor leads above the motor. Position square ring on bearing housing and lower housing over motor and into pilot, aligning handle so that it is parallel to motor end bell reliefs. Apply thread locking compound to threads on cap screws and place into holes and torque to 24 ft/lbs.



**Handle seal parts with extreme care. DO NOT damage lapped surfaces.**

**Seal** - (See Figure 2) Clean and oil seal cavities in bearing housing and seal plate. Lightly oil (**Do not use grease**) outer surface of inboard and outboard stationary members of seal. Press inboard stationary member firmly into bearing housing and outboard stationary into seal plate, using a seal pusher tool. Nothing but the seal pusher tool is to come in contact with seal face.



**IMPORTANT!** - Hammering on the seal pusher tool will damage the seal face.

Be sure the stationary members are in straight and that the rubber ring is not out of its groove. Lightly oil (**Do not use grease**) shaft and inner surface of bellows on rotating member. With lapped surface facing bearing housing, slide rotating member onto shaft using seal pusher tool, until lapped faces are together. It is extremely important to keep seal faces clean during assembly. Dirt particles lodged between faces will cause the seal to leak.

Be sure driving lugs in retainer are matched in rotating member of seal. Place spring over shaft and in place on rotating member, making sure it is seated in retainer and not cocked or resting on bellows tail. Lightly oil shaft and inner surface of outboard rotating member.

With tail section toward bearing housing, slide rotating member onto shaft with seal pusher tool until retainer engages spring and spring is compressed slightly.

Spring should be properly engaged in both retainers.

Place seal plate over shaft onto bearing housing, being careful not to damage outboard stationary member and align holes for cap screws.

Thread cap screws into bearing housing and tighten. Refill chamber with oil.

**Conduit Box Assembly** - Check power and control cables for cracks or damage and replace complete conduit box if required. (See Figure 3) Bring motor wires through opening in top of motor housing, check sleeving and replace if damaged. Position square ring in conduit box and reconnect leads using connectors and insulators. See wiring schematics.

Refill with cooling oil. Position conduit box with square ring on motor housing. Apply thread locking compound to cap screws threads and torque to 16 ft/lbs.

Remove gland nuts and, washers and, and grommets and from conduit box, inspect and replace if damaged (See Figure 3). Reassemble by inserting one washer, grommet, one more washer and gland nut into conduit box. Torque gland nuts to 15 ft/lbs to prevent leakage.

**Impeller and Volute** - Install impeller by applying a thin film of oil to motor shaft and slide impeller straight onto shaft, keeping keyways lined up. Drive key into keyway. Locate washer, apply thread lock primer (such as Loctite® Primer T), let set per manufacturer's directions. Apply thread locking compound to threads on cap screw, and thread into shaft and torque to 35 ft/lbs.

Place gasket on volute and install impeller and motor assembly over studs and onto volute. Apply thread locking compound to threads of studs and thread nuts onto studs and torque to 24 ft/lbs. Check for binding by rotating impeller. Clearance between the impeller and volute should be approximately 0.012 inch.

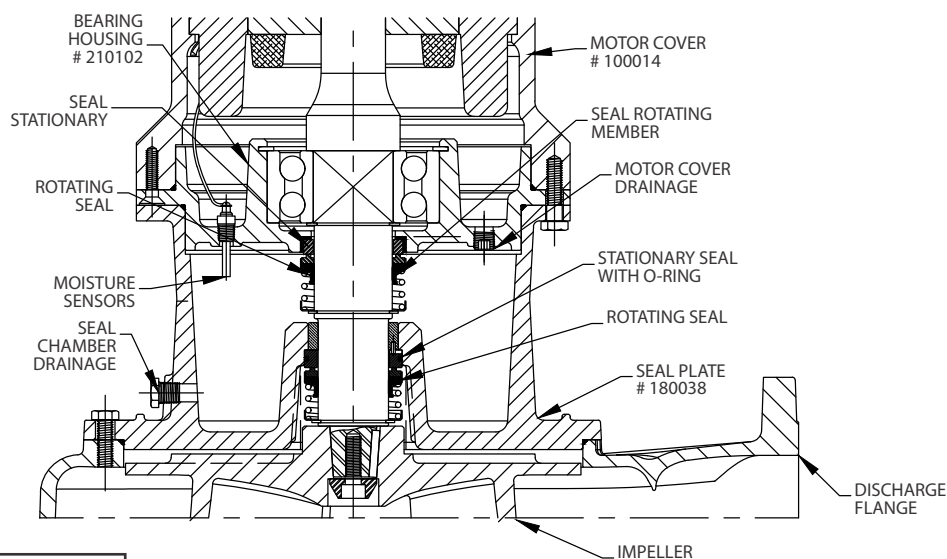

**Figure 2**

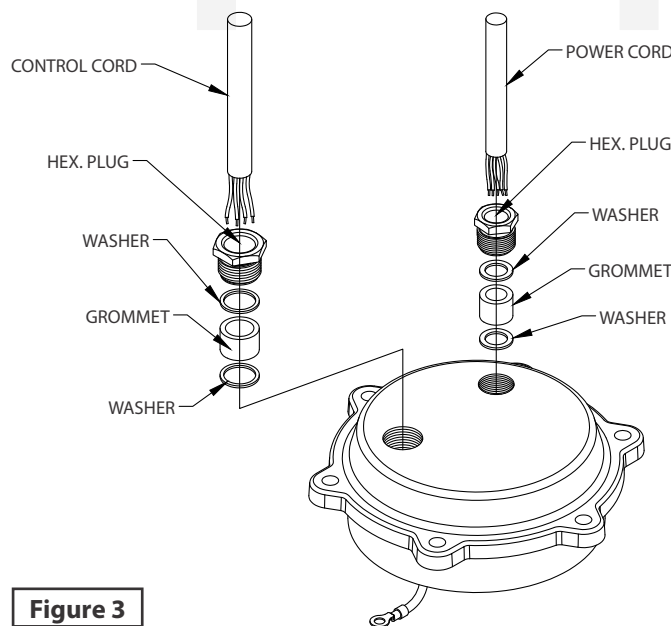

**Figure 3**

## ELECTRICAL CONNECTION

### THREE-PHASE 460V

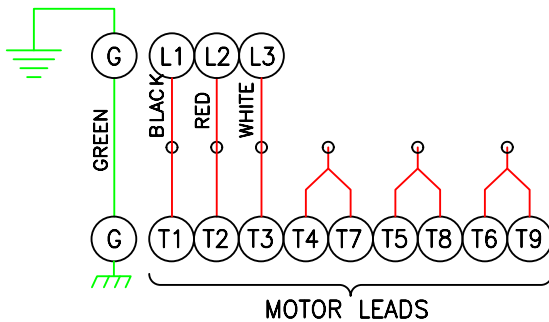

MOTOR LEAD NUMBER  
GREEN COLOR (GROUND)

- 1 A PHASE
- 2 A PHASE
- 3 A PHASE
- 4 & 7 TOGETHER
- 5 & 8 TOGETHER
- 6 & 9 TOGETHER

FRAME	HP	POLES. NO.	
250	20&25	4	HM50
250	30	4	HM51
250	5,7.5&10	6	HY86
250	15&20	6	HY87
210	15	4	HM49

### THREE-PHASE 230V

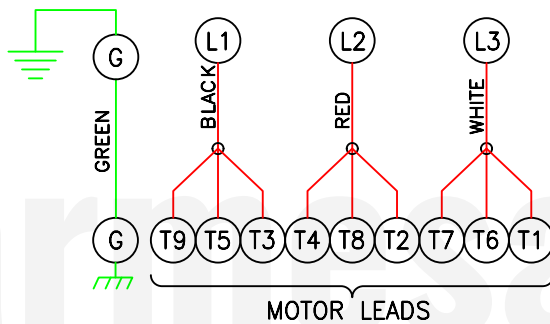

MOTOR LEAD NUMBER  
GREEN COLOR (GROUND)

- 9, 5 & 3 TOGETHER
- 4, 8 & 2 TOGETHER
- 7, 6 & 1 TOGETHER

FRAME	HP	POLES. NO.	
250	20&25	4	HM50
250	30	4	HM51
250	5,7.5&10	6	HY86
250	15&20	6	HY87

## CONTROL CABLE

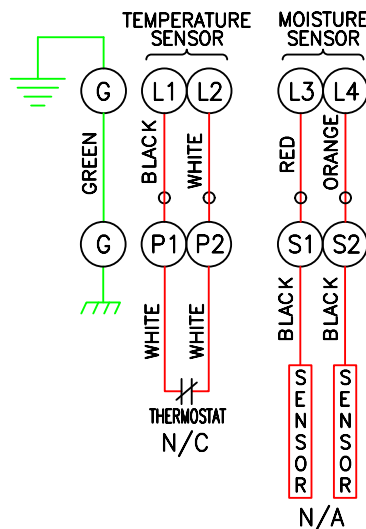



► Motor frame 210

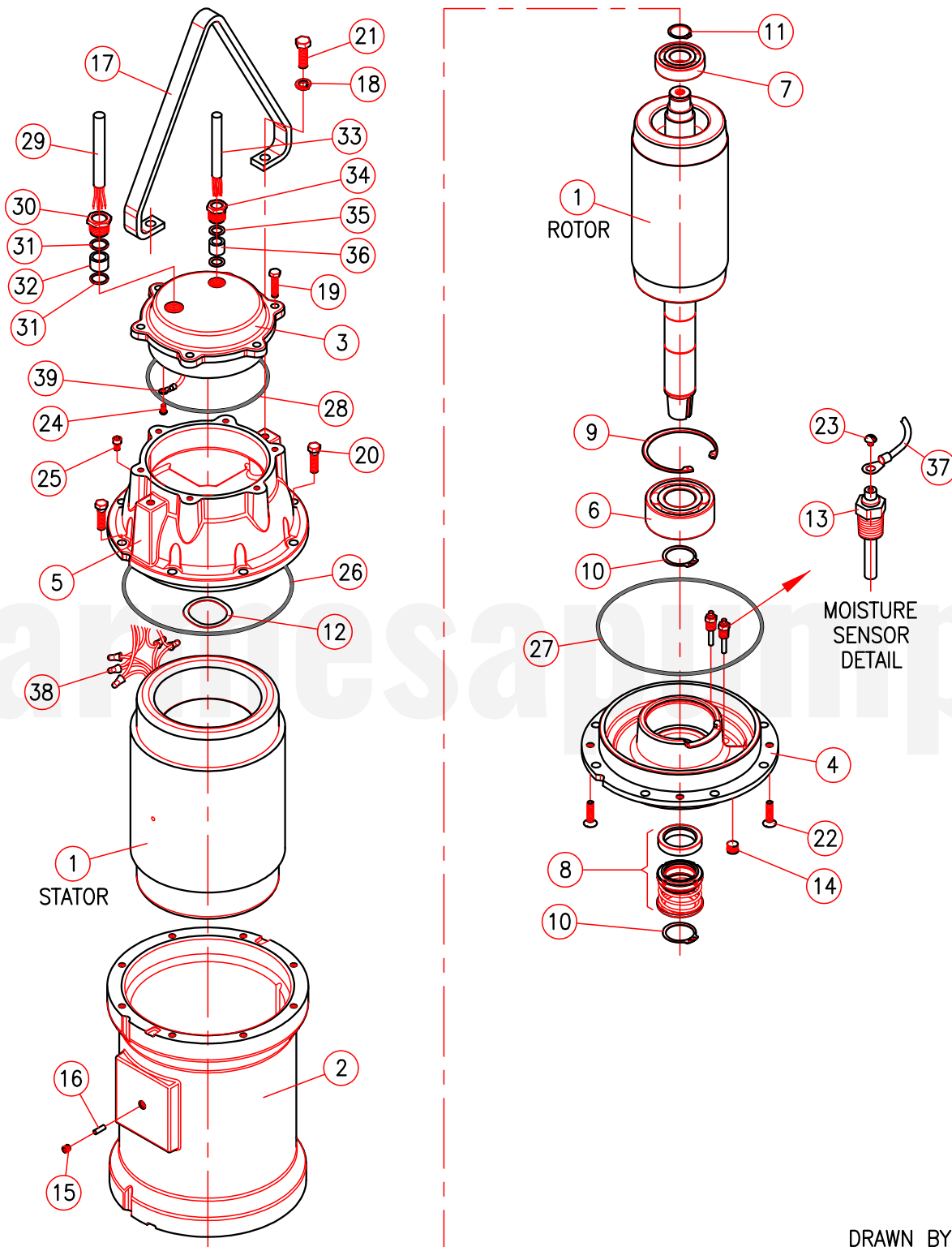

DRAWN BY:  
LEOPOLDO MONTALVO

For repair part please supply: model number and serial as shown on name plate, and part description and part number as shown on parts list.

## ► Motor frame 210

Item	Part Number	Description	Qty.	Material
1	40040360	Motor 15 HP 1750 210 FR	1	
2	03100012	Motor Housing Lower	1	Cast Iron, Class 30
3	03100013	Conduit Box & Cable Assembly	1	Cast Iron, Class 30
4	03210101	Bearing Bracket	1	Cast Iron, Class 30
5	03220029	Motor Housing Upper	1	Cast Iron, Class 30
6	31020041	Bearing Lower # 3309-A/C3	1	SKF / FAG
7	31020045	Bearing Upper # 6306-C3	1	SKF / FAG
8	31030290E	Mechanical Seal Inner 1.750"Ø Type 21, seal with Cup Seat	1	Car / Cer / Buna / SS
9	31010012	Retaining Ring # N5002-393	1	Steel
10	31010008C	Retaining Ring # 5100-175	2	420 SS
11	31010003	Retaining Ring # 5100-118	1	420 SS
12	91010019	Springer Washer 72 mm	1	Steel
13	31160001	Moisture Sensor # 39383	2	Steel / Plastico
14	93010115	Pipe Plug Dry Seal de 3/8"	1	304 SS
15	93010116	Pipe Plug Dry Seal de 1/8"	1	304 SS
16	91010180	Dowel Pin 1/4"Ø x 3/4"	1	1018
17	30400844E	Lifting Handle	1	304 SS
18	91010062	Lockwasher 1/2" SS	2	304 SS
19	91010346	Screw Hex. Head 3/8" x 1 1/2" SS	6	18-8 SS
20	91010366E	Screw Hex. Head 7/16" x 1 1/2" SS	8	18-8 SS
21	91010351	Screw Hex. Head 1/2" x 1 1/2" SS	2	18-8 SS
22	91010402	Socket Flat Head Screw 3/8" x 1 1/2" SS	4	304 SS
23	91010403	Machine Screw Moist 6-32 x 1/4" SS	2	304 SS
24	91010404	Ground Screw 1/4" x 1/2" SS	1	304 SS
25	91010330	Socket Head Screw 5/16" x 1/2" SS	1	304 SS
26	92010064	O-Ring # 277, Motor Housing Upper	1	Buna N
27	92010062	O-Ring # 276, Bearing Bracket	1	Buna N
28	92010075	O-Ring # 261, Conduit Box & Cable Assy.	1	Buna N
29	31030003	Power Cable 10/4	1	40 Feet
30	30400903	Hex Head Plug	1	304 SS
31	91010055	Friction Ring # 54746 SS	2	304 SS
32	92010001	Grommet	1	
33	31030005	Cord. Set Moist & Temp 18/5	1	40 Feet
34	30400901	Hex Head Plug	1	304 SS
35	91010057	Friction Ring # 21531 SS	2	304 SS
36	92010005	Grommet	1	
37	31030011	Moisture Sensor Wire	2	
38	94010012	Wire Connector ( 230 Volts)	8	Plastic
		Wire Connector ( 460 Volts)	11	
39	94010044	Connector 5/16" (Ground Wire)	1	
40	31010031	Motor Oil (Motor's Housing Cavity)	5.6 lts.	

For repair part please supply: model number and serial as shown on name plate, and part description and part number as shown on parts list.

► Motor frame 210

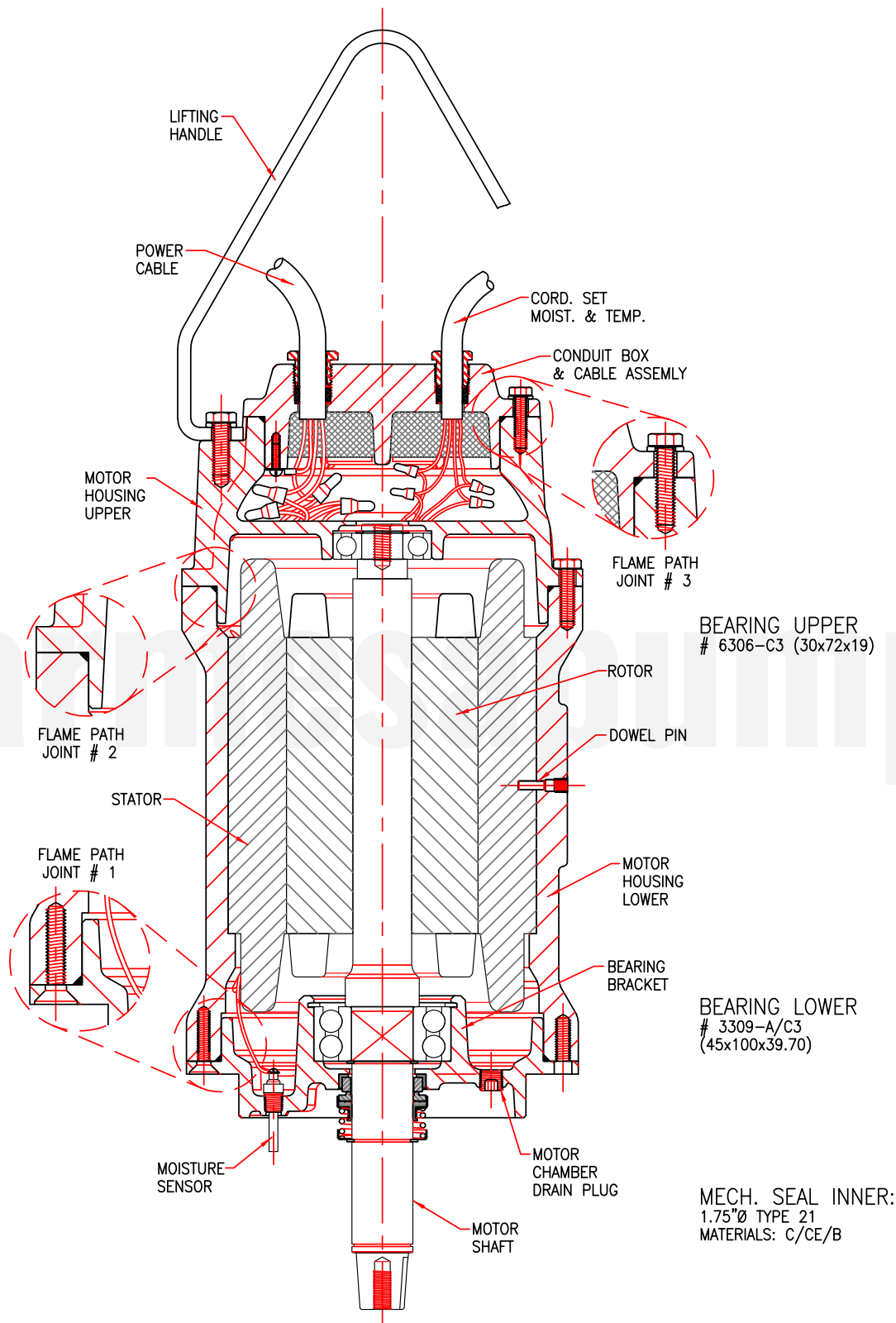

For repair part please supply: model number and serial as shown on name plate, and part description and part number as shown on parts list.

► Motor frame 250

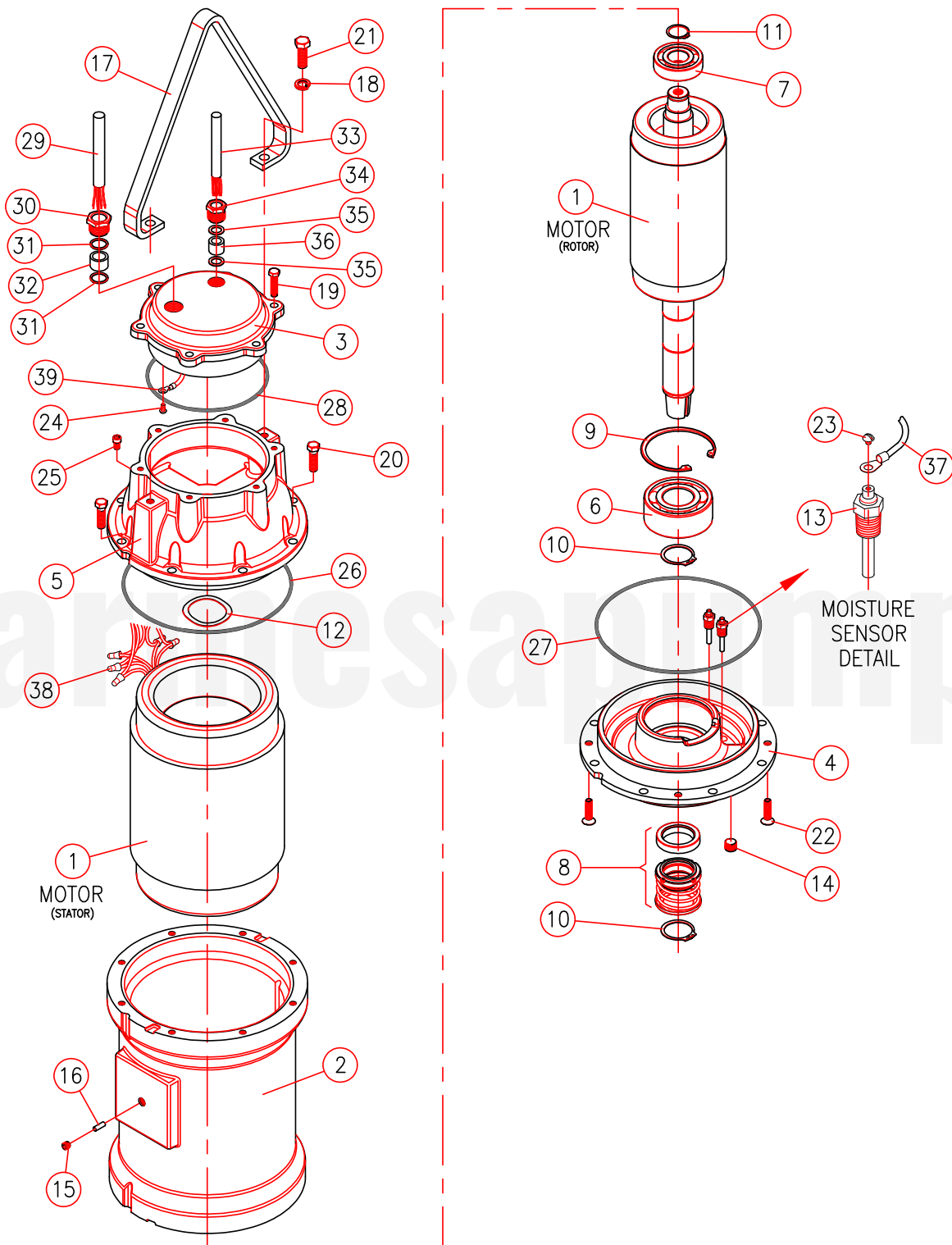

For repair part please supply: model number and serial as shown on name plate, and part description and part number as shown on parts list.

## ► Motor frame 250

Item	Part Number	Description	Qty.	Material
1	40040362	Motor 20 hp 1750 FR25	1	
	40040362	Motor 25 hp 1750 FR25		
	40040364	Motor 30 hp 1750 FR25		
	40040366	Motor 40 hp 1750 FR25		
	40040378	Motor 7.5 hp 1150 FR25		
	40040378	Motor 10 hp 1150 FR25		
	40040380	Motor 15 hp 1150 FR25		
	40040380	Motor 20 hp 1150 FR25		
2	03100014	Motor Housing Lower	1	Cast Iron, Class 30
3	03100013B	Conduit Box & Cable Assembly	1	Cast Iron, Class 30
4	03210102	Bearing Bracket	1	Cast Iron, Class 30
5	03220030	Motor Housing Upper	1	Cast Iron, Class 30
6	31020041	Bearing Lower # 3313-A/C3	1	SKF / FAG
7	31020025	Bearing Upper # 6309-C3	1	SKF / FAG
8	31030139L	Mechanical Seal Inner 2.500"Ø Type 21, seal with Cup Seat	1	Car / Cer / Buna / SS
9	31010012D	Retaining Ring # N5002-550	1	Steel
10	31010017D	Retaining Ring # 5100-250	2	420 SS
11	31010015	Retaining Ring # 5100-177	1	420 SS
12	91010019	Springer Washer 72 mm	1	Steel
13	31160001	Moisture Sensor # 39383	2	Steel / Plastico
14	93010115	Pipe Plug Dry Seal de 3/8"	1	304 SS
15	93010116	Pipe Plug Dry Seal de 1/8"	1	304 SS
16	91010180	Dowel Pin 1/4"Ø x 3/4"	1	1018
17	30400844F	Lifting Handle	1	304 SS
18	91010062	Lockwasher 1/2" SS	2	304 SS
19	91010345C	Screw Hex. Head 3/8" x 1/4" SS	6	18-8 SS
20	91010366E	Screw Hex. Head 7/16" x 1/2" SS	8	18-8 SS
21	91010351	Screw Hex. Head 1/2" x 1/2" SS	2	18-8 SS
22	91010402	Socket Flat Head Screw 3/8" x 1/2" SS	4	304 SS
23	91010403	Machine Screw Moist 6-32 x 1/4" SS	2	304 SS
24	91010404	Ground Screw 1/4" x 1/2" SS	1	304 SS
25	91010330	Socket Head Screw 5/16" x 1/2" SS	1	304 SS
26	92010064	O-Ring # 277, Motor Housing Upper	1	Buna N
27	92010062	O-Ring # 276, Bearing Bracket	1	Buna N
28	92010075	O-Ring # 261, Conduit Box & Cable Assy.	1	Buna N
29	31030003	Power Cable 10/4	1	40 Feet
30	30400903	Hex Head Plug	1	304 SS
31	91010055	Friction Ring # 54746 SS	2	304 SS
32	92010001	Grommet	1	
33	31030005	Cord. Set Moist & Temp 18/5	1	40 Feet
34	30400901	Hex Head Plug	1	304 SS
35	91010057	Friction Ring # 21531 SS	2	304 SS
36	92010005	Grommet	1	
37	31030011	Moisture Sensor Wire	2	
38	94010012	Wire Connector ( 230 Volts)	8	Plastic
		Wire Connector ( 460 Volts)	11	
39	94010044	Connector 5/16" (Ground Wire)	1	
40	31010031	Motor Oil (Motor's Housing Cavity)	5.6 lts.	

For repair part please supply: model number and serial as shown on name plate, and part description and part number as shown on parts list.

► Motor frame 250

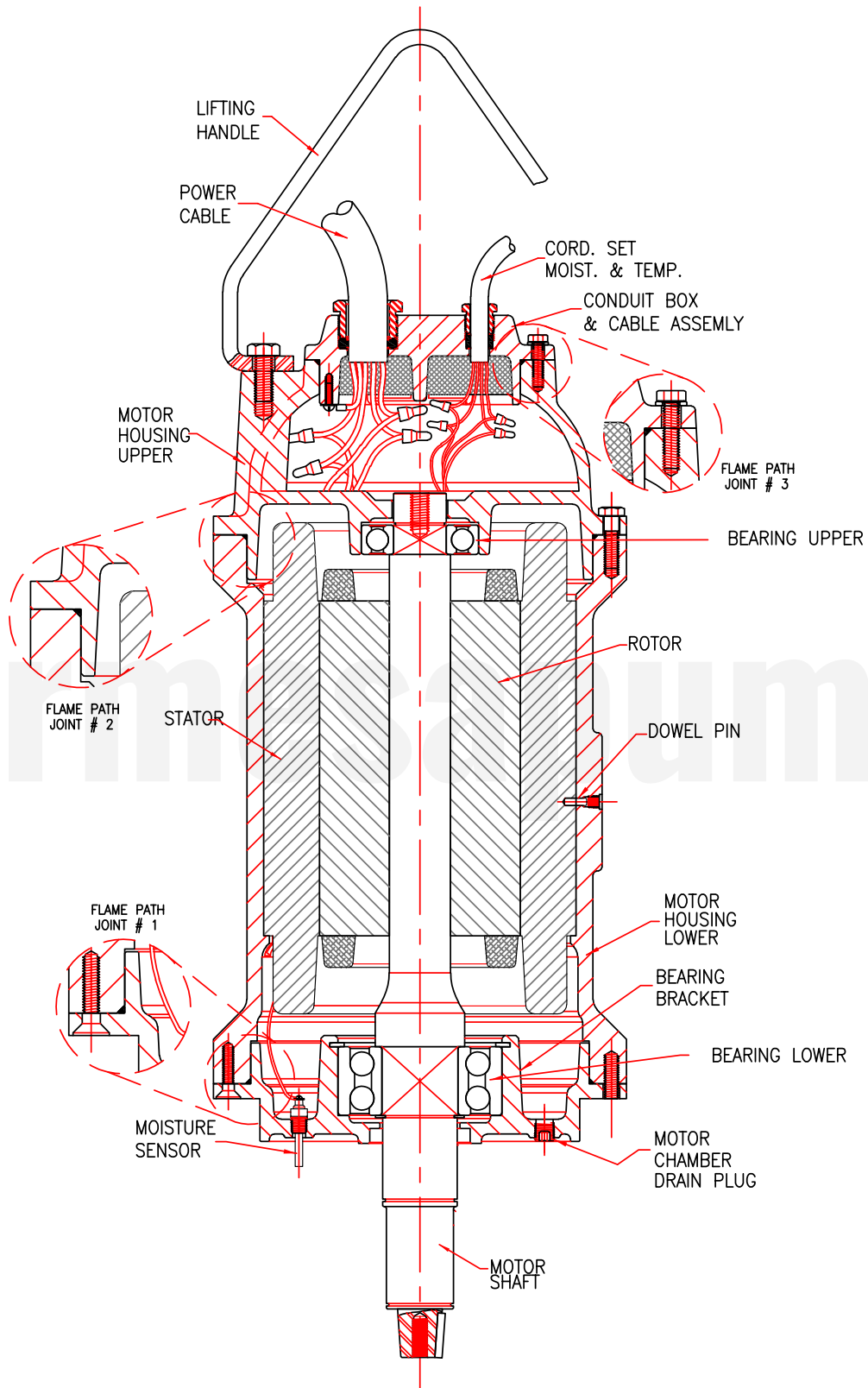

For repair part please supply: model number and serial as shown on name plate, and part description and part number as shown on parts list.

► Motor frame 320

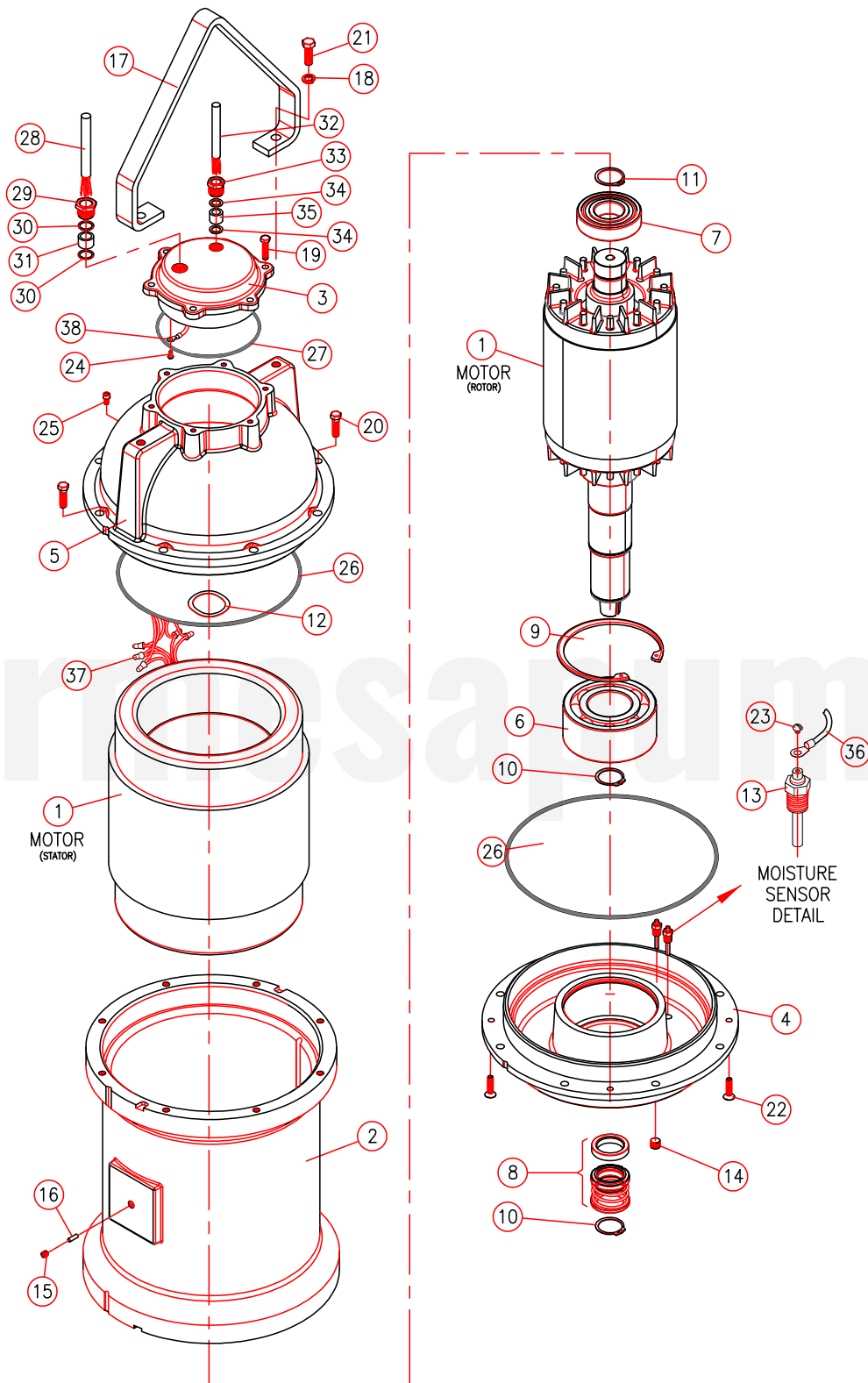

For repair part please supply: model number and serial as shown on name plate, and part description and part number as shown on parts list.

## ► Motor frame 320

Item	Part Number	Description	Qty.	Material
1	40040368	Motor 50 hp 1750 RPM	1	
	40040370	Motor 60 hp 1750 RPM		
	40040372	Motor 75 hp 1750 RPM		
2	03100015	Motor Housing Lower	1	Cast Iron, Class 30
3	03100013B	Conduit Box & Cable Assembly	1	Cast Iron, Class 30
4	03210103	Bearing Bracket	1	Cast Iron, Class 30
5	03220031	Motor Housing Upper	1	Cast Iron, Class 30
6	31020041B	Bearing Lower # 3315-A/C3	1	SKF / FAG
7	31020015	Bearing Upper # 6311-C3	1	SKF / FAG
8	31030139P	Mechanical Seal Inner 2.875"Ø	1	Car / Cer / Buna / SS
		Type 21, seal with Cup Seat		
9	31010012F	Retaining Ring # 5002-625	1	Steel
10	31010017F	Retaining Ring # 5100-293	2	420 SS
11	31010015F	Retaining Ring # 5100-206	1	420 SS
12	N/A	Springer Washer 120 mm	1	Steel
13	31160001	Moisture Sensor # 39383	2	Steel / Plastico
14	93010115	Pipe Plug Dry Seal de 3/8"	1	304 SS
15	93010116	Pipe Plug Dry Seal de 1/8"	1	304 SS
16	91010180	Dowel Pin 1/4"Ø x 3/4"	1	1018
17	30400844G	Lifting Handle Frame 320	1	304 SS
18	91010062	Lockwasher 5/8" SS	2	304 SS
19	91010345C	Screw Hex. Head 3/8" x 1 1/4" SS	6	18-8 SS
20	91010351B	Screw Hex. Head 1/2" x 1 3/4" SS	16	18-8 SS
21	91010356	Screw Hex. Head 5/8" x 2" SS	2	18-8 SS
22	91010402	Socket Flat Head Screw 3/8" x 1 1/2" SS	4	304 SS
23	91010403	Machine Screw Moist 6-32 x 1/4" SS	2	304 SS
24	91010404	Ground Screw 1/4" x 1/2" SS	1	304 SS
25	91010330	Socket Head Screw 5/16" x 1/2" SS	1	304 SS
26	92010064G	O-Ring # 280, Motor Housing Upper and Bearing Bracket	2	Buna N
27	92010075	O-Ring # 261, Conduit Box & Cable Assy.	1	Buna N
28	31030003	Power Cable 10/4	1	40 Feet
29	30400903	Hex Head Plug	1	304 SS
30	91010055	Friction Ring # 54746 SS	2	304 SS
31	92010001	Grommet	1	
32	31030005	Cord. Set Moist & Temp 18/5	1	40 Feet
33	30400901	Hex Head Plug	1	304 SS
34	91010057	Friction Ring # 21531 SS	2	304 SS
35	92010005	Grommet	1	
36	31030011	Moisture Sensor Wire	2	
37	94010012	Wire Connector ( 230 Volts)	8	Plastic
		Wire Connector ( 460 Volts)		
38	94010044	Connector 5/16" (Ground Wire)	1	
39	31010031	Motor Oil (Motor's Housing Cavity)	4 lts.	

For repair part please supply: model number and serial as shown on name plate, and part description and part number as shown on parts list.



## ► Motor frame 320

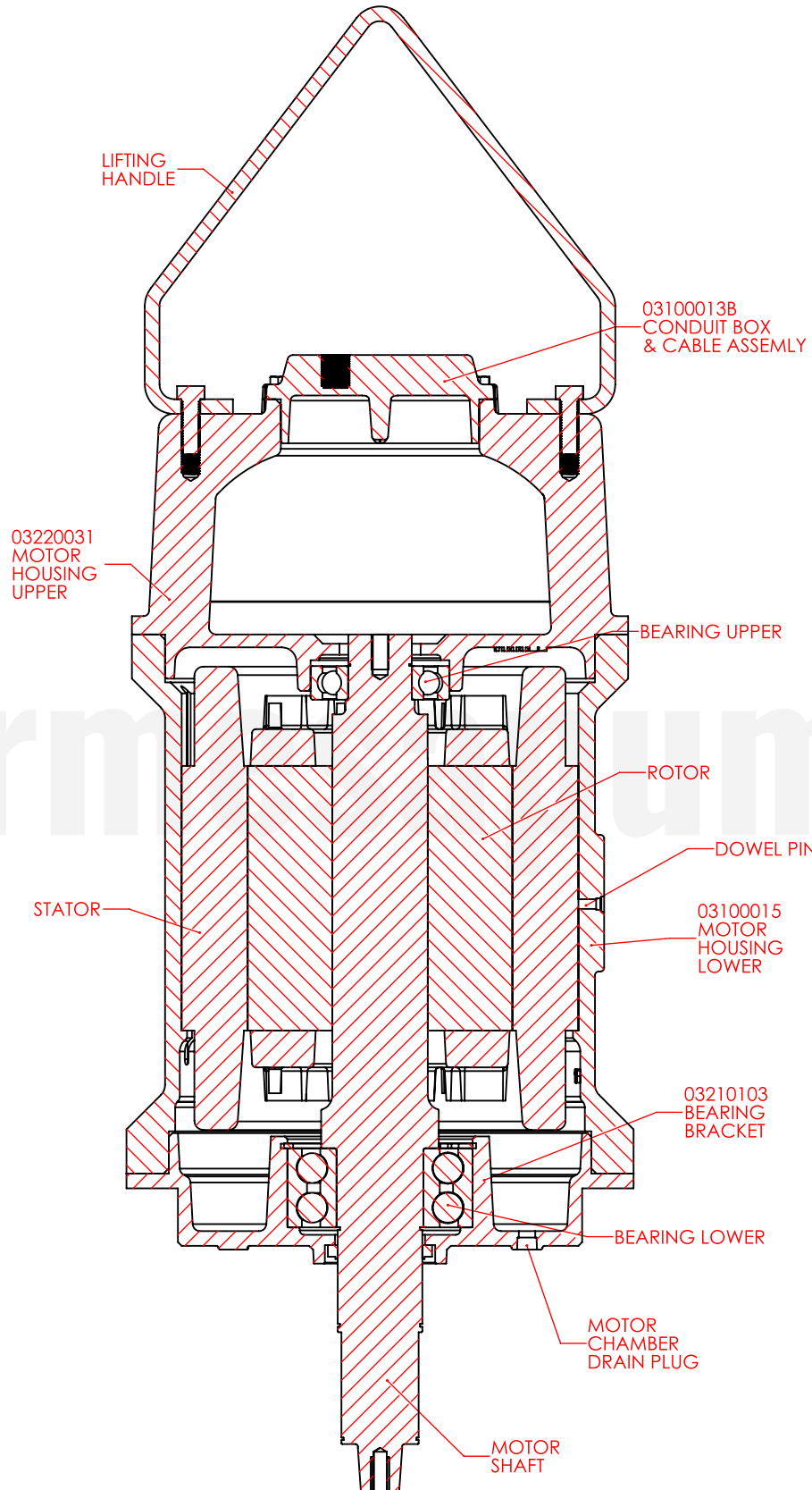

For repair part please supply: model number and serial as shown on name plate, and part description and part number as shown on parts list.

► 4SWL frame 210

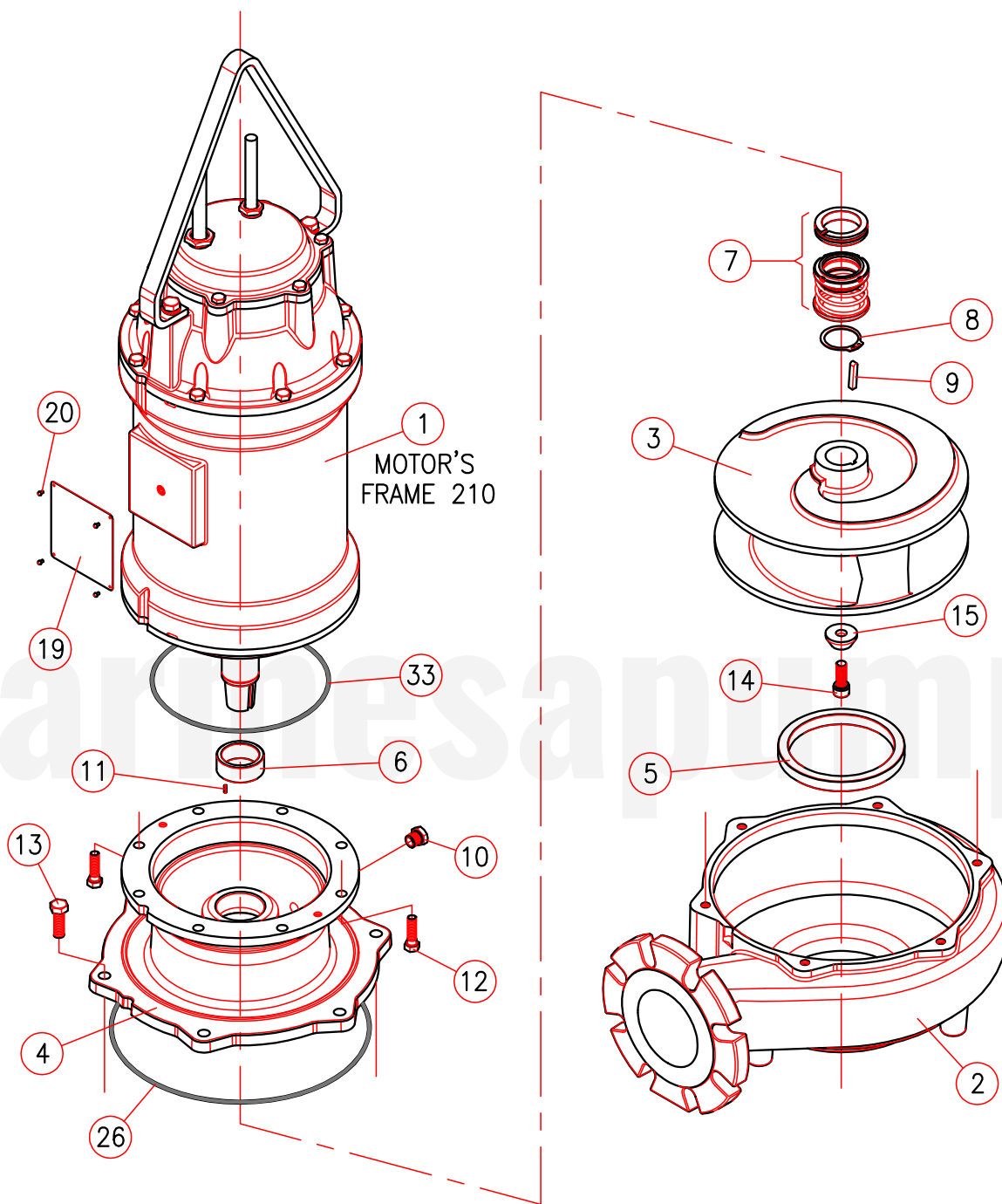

DRAWN BY:  
LEOPOLDO MONTALVO

For repair part please supply: model number and serial as shown on name plate, and part description and part number as shown on parts list.

## ► 4SWL frame 210

Item	Part Number	Description	Qty.	Material
1	40048016	Motor Frame 210, 15 hp - 1750 rpm	1	N/A
2	03090107	Volute	1	Cast Iron, Class 30
3	03140241G	Impeller 8.86"Ø	1	Ductile Iron, 65-45-12
4	03180036	Seal Plate	1	Cast Iron, Class 30
5	30400374	Wear Ring Volute 4SWM/H	1	Bronze C954
6	30400624G	Bearing Sleeve	1	Bronze SAE 40
7	31030290E	Mechanical Seal Outer 1.750"Ø Type 21, Seal with O-Ring slotted	1	Sic / Sic / Buna / SS
8	31010008C	Retaining Ring # 5100-175 SS	1	420 SS
9	30400639	Key ¼" x ¼" x 1½" SS	1	304 SS
10	93010131	Hex Head Plug 3/8" SS # 22932	1	304 SS
11	91010184C	Roll Pin 1/8"Ø x ½" SS	1	420 SS
12	91010348E	Screw Hex. Head 7/16" x 2.00" SS	8	18-8 SS
13	91010351	Screw Hex. Head ½" x 1½" SS	6	18-8 SS
14	91010334B	Socket Head Screw ½"-20UNF x 1¼" lg.	1	304 SS
15	30400413	Impeller Washer SS	1	304 SS
16	92010064E	O-Ring # 278, Volute	1	Buna N
17	92010089	O-Ring # 275, Seal Plate	1	Buna N
18	31010031	Motor Oil (Seal's Plate Cavity)	3 lts.	
19	94010074	Nameplate	1	304 SS
20	91010192	Rivet SS # 001628	4	Stainless Steel

For repair part please supply: model number and serial as shown on name plate, and part description and part number as shown on parts list.

► 4SWL frame 210

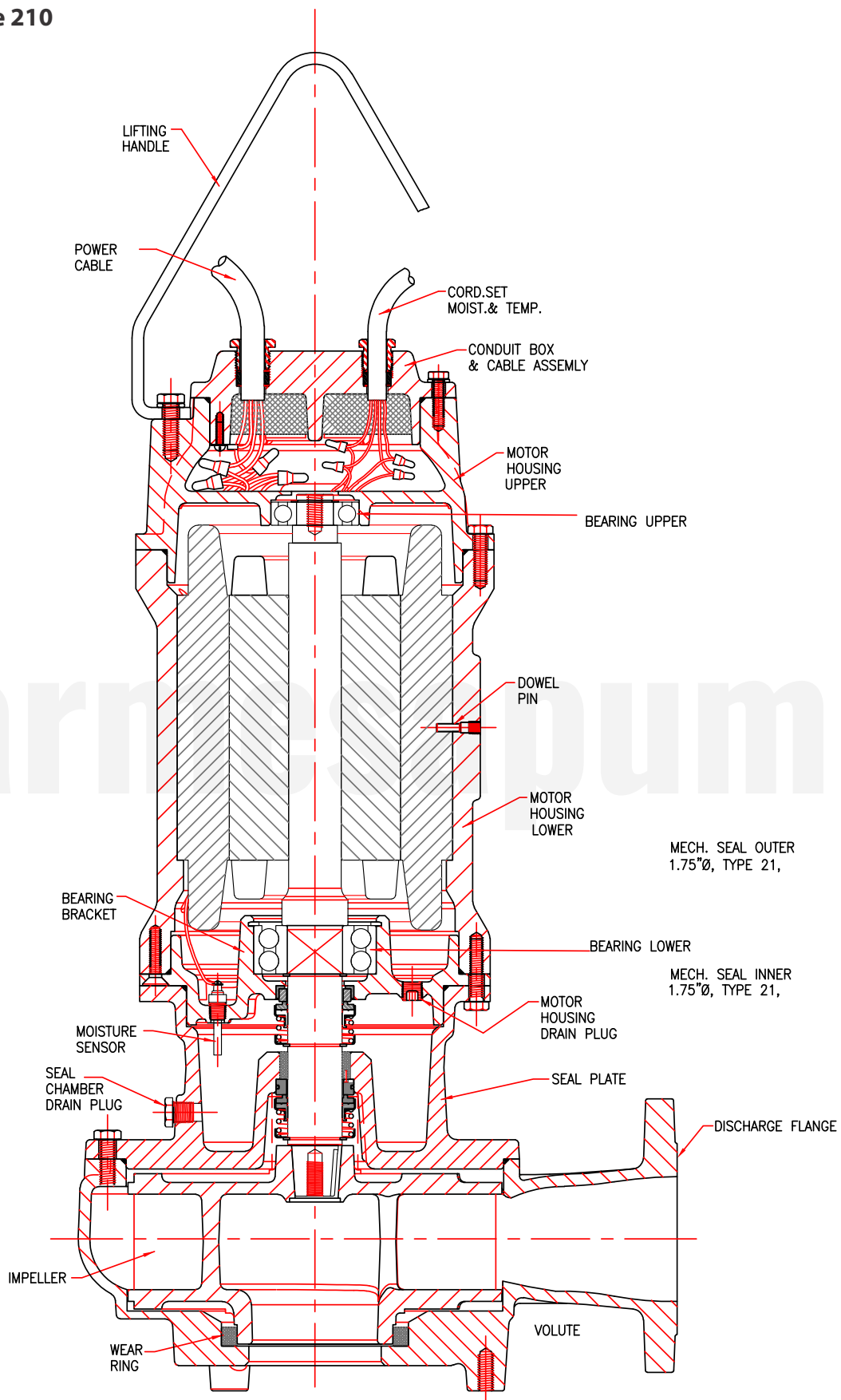

For repair part please supply: model number and serial as shown on name plate, and part description and part number as shown on parts list.

► 4SWL frame 250

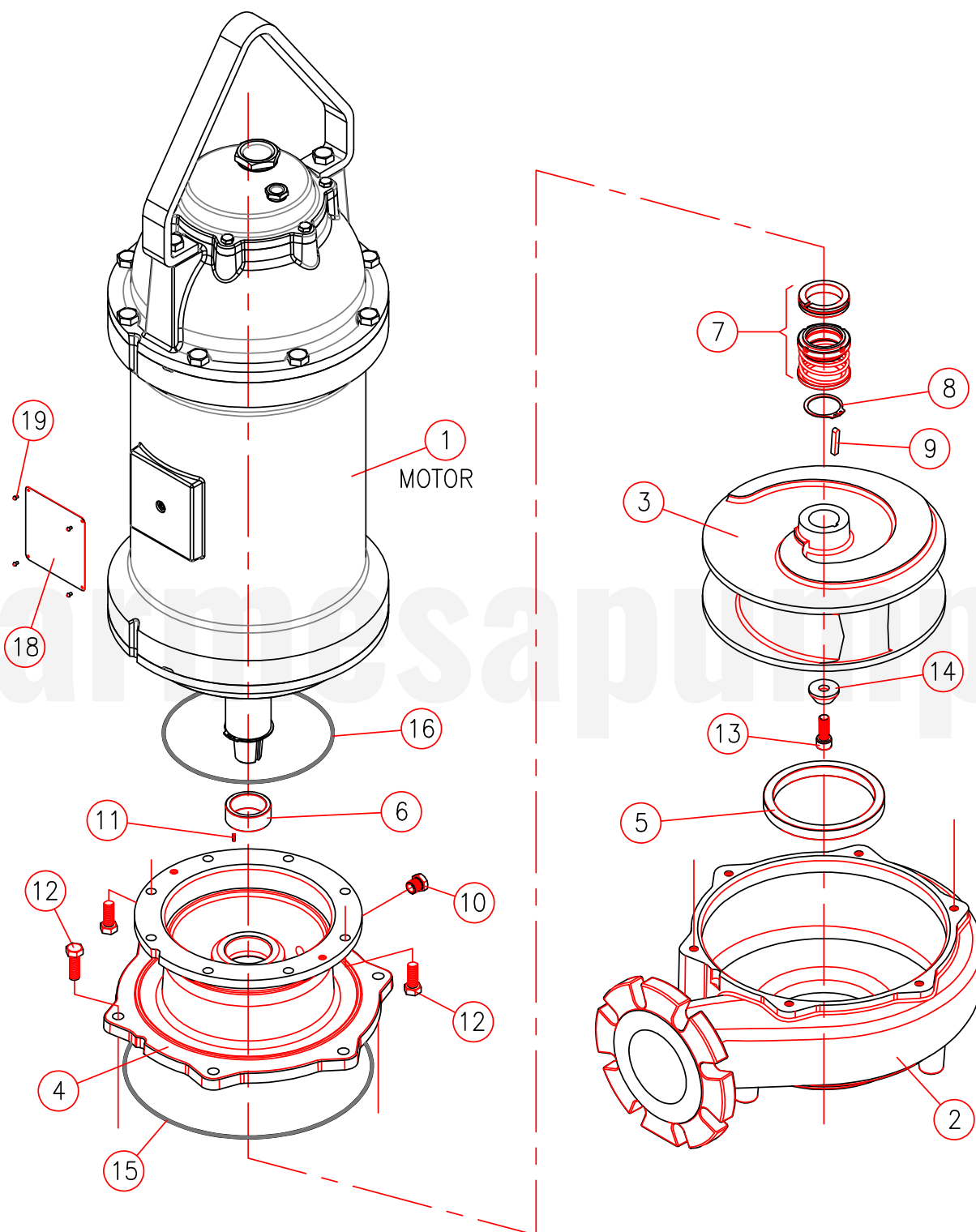

For repair part please supply: model number and serial as shown on name plate, and part description and part number as shown on parts list.

## ► 4SWL frame 250

Item	Part Number	Description	Qty.	Material
1	40043013	Motor Frame 250, 20 hp - 1750 rpm	1	N/A
	40043014	Motor Frame 250, 25 hp - 1750 rpm		
	40043015	Motor Frame 250, 30 hp - 1750 rpm		
	40043017	Motor Frame 250, 40 hp - 1750 rpm		
	40043030	Motor Frame 250, 7.5 hp - 1150 rpm		
	40043030	Motor Frame 250, 10 hp - 1150 rpm		
	40043032	Motor Frame 250, 15 hp - 1150 rpm		
2	03090107	Volute	1	Cast Iron, Class 30
3	03140241	Impeller 11.61"Ø, 40 hp, 1750 rpm	1	Ductile Iron, 65-45-12
		Impeller 11.61"Ø, 15 hp, 1150 rpm		
	03140241B	Impeller 11.22"Ø, 10 hp, 1150 rpm		
	03140241C	Impeller 10.83"Ø, 30 hp, 1750 rpm		
	03140241D	Impeller 10.43"Ø, 7.5 hp, 1150 rpm		
	03140241E	Impeller 10.04"Ø, 25 hp, 1750 rpm		
	03140241F	Impeller 9.45"Ø, 20 hp, 1750 rpm		
4	03180037	Seal Plate	1	Cast Iron, Class 30
5	30400374	Wear Ring Volute 4SWM/H	1	Bronze C954
6	30400624H	Bearing Sleeve 250	1	Bronze SAE 40
7	31030139K	Mechanical Seal Outer 2.250"Ø Type 21, Seal with O-Ring slotted	1	Sic / Sic / Buna / SS
8	31010010	Retaining Ring # 5100-225 SS	1	420 SS
9	30400639	Key ¼" x ¼" x 1½" SS	1	304 SS
10	93010131	Hex Head Plug 3/8" SS # 22932	1	304 SS
11	91010184C	Roll Pin 1/8"Ø x ½" SS	1	420 SS
12	91010351	Screw Hex. Head ½" x 1½" SS	14	18-8 SS
13	91010334B	Socket Head Screw ½"-20UNF x 1¼" lg.	1	304 SS
14	30400413	Impeller Washer SS	1	304 SS
15	92010064E	O-Ring # 278, Volute	1	Buna N
16	92010089	O-Ring # 275, Seal Plate	1	Buna N
17	31010031	Motor Oil (Seal's Plate Cavity)	5.5 lt.	
18	94010074	Nameplate	1	304 SS
19	91010192	Rivet SS # 001628	4	Stainless Steel

For repair part please supply: model number and serial as shown on name plate, and part description and part number as shown on parts list.

► 4SWL frame 250

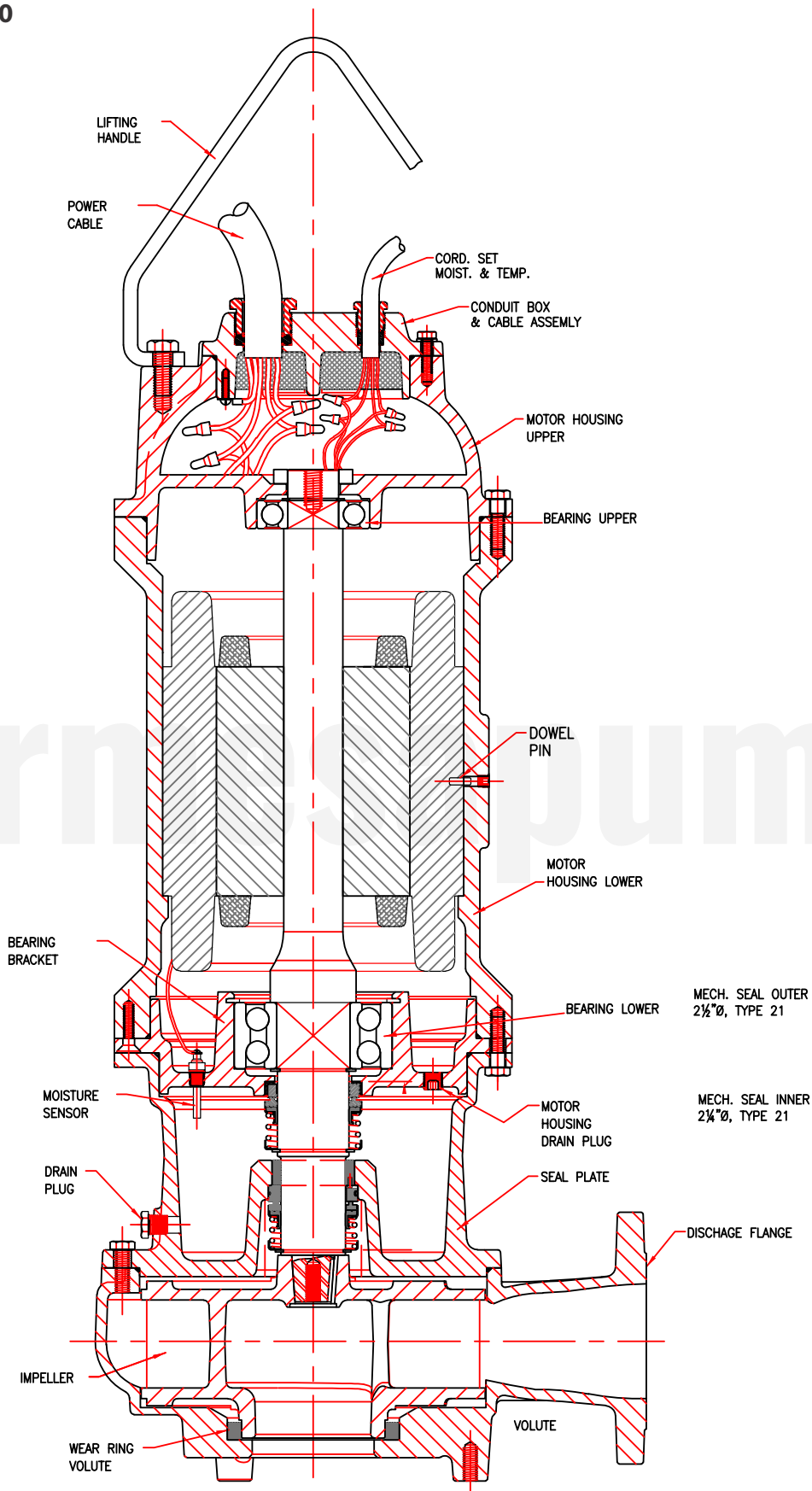

For repair part please supply: model number and serial as shown on name plate, and part description and part number as shown on parts list.

► 4SWM frame 250

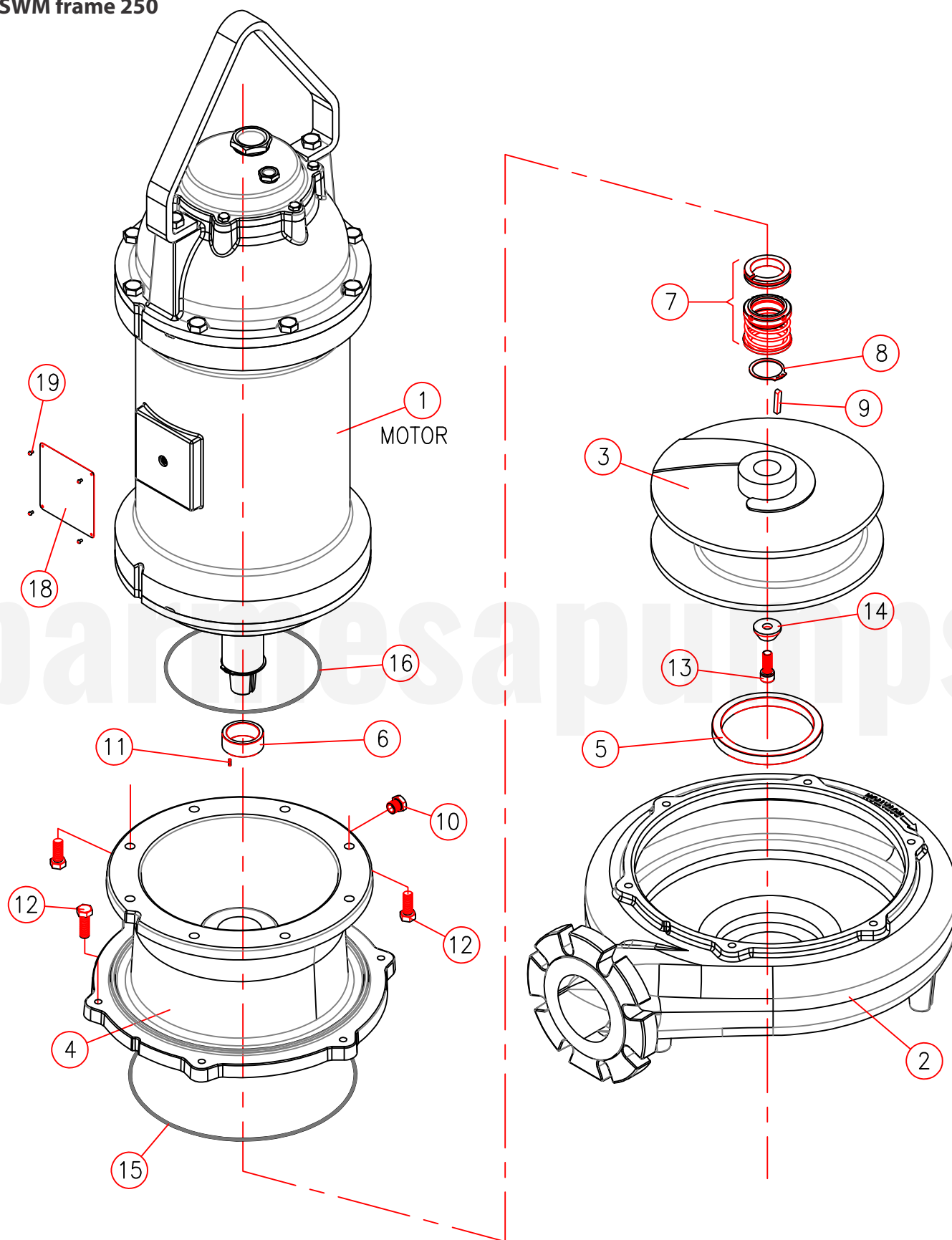

For repair part please supply: model number and serial as shown on name plate, and part description and part number as shown on parts list.



## ► 4SWM frame 250

Item	Part Number	Description	Qty.	Material
1	40043013	Motor Frame 250, 20 hp - 1750 rpm	1	N/A
	40043013	Motor Frame 250, 25 hp - 1750 rpm		N/A
	40043015	Motor Frame 250, 30 hp - 1750 rpm		N/A
	40043017	Motor Frame 250, 40 hp - 1750 rpm		N/A
2	03090109	Volute	1	Cast Iron, Class 30
3	03140242A	Impeller 11.81"Ø, 40 hp, 1750 rpm		
	03140242B	Impeller 10.83"Ø, 30 hp, 1750 rpm		
	03140242C	Impeller 10.24"Ø, 25 hp, 1750 rpm		
	03140242D	Impeller 9.45"Ø, 20 hp, 1750 rpm		
4	03180038	Seal Plate	1	Cast Iron, Class 30
5	30400374	Wear Ring Volute 4SWM/H	1	Bronze C954
6	30400624H	Bearing Sleeve 250	1	Bronze SAE 40
7	31030139K	Mechanical Seal Outer 2.250"Ø Type 21, Seal with O-Ring slotted	1	Sic / Sic / Buna / SS
8	31010010	Retaining Ring # 5100-225 SS	1	420 SS
9	30400639	Key ¼" x ¼" x 1½" SS	1	304 SS
10	93010131	Hex Head Plug 3/8" SS # 22932	1	304 SS
11	91010184C	Roll Pin 1/8"Ø x ½" SS	1	420 SS
12	91010351	Screw Hex. Head ½" x 1½" SS	14	18-8 SS
13	91010334B	Socket Head Screw ½"-20UNF x 1¼" lg.	1	304 SS
14	30400413	Impeller Washer SS	1	304 SS
15	92010064G	O-Ring # 280, Volute	1	Buna N
16	92010089	O-Ring # 275, Seal Plate	1	Buna N
17	31010031	Motor Oil (Seal's Plate Cavity)	5.5 lt.	N/A
18	94010074	Nameplate	1	304 SS
19	91010192	Rivet SS # 001628	4	Stainless Steel

For repair part please supply: model number and serial as shown on name plate, and part description and part number as shown on parts list.

► 4SWM frame 250

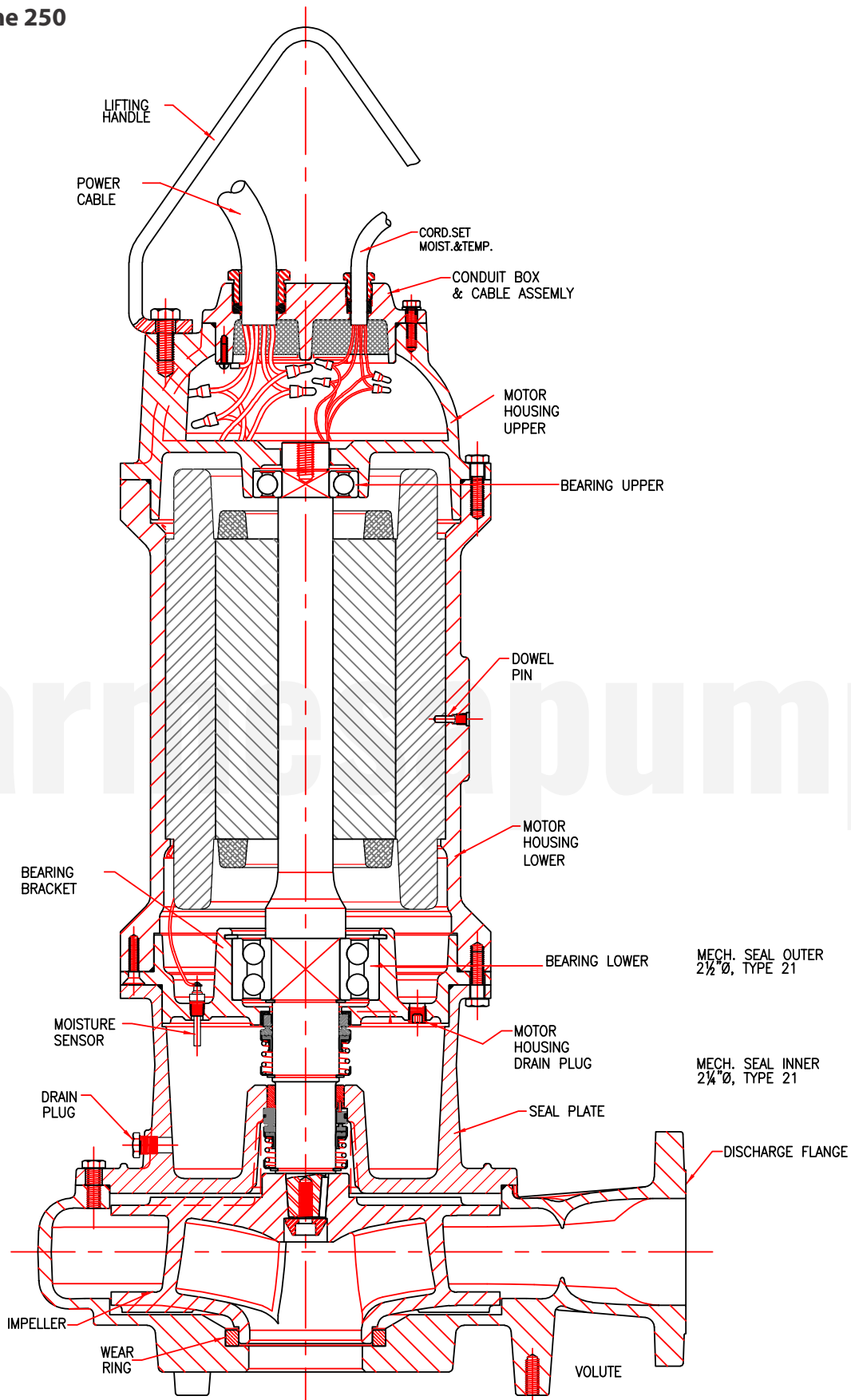

For repair part please supply: model number and serial as shown on name plate, and part description and part number as shown on parts list.

► 4SWM frame 320

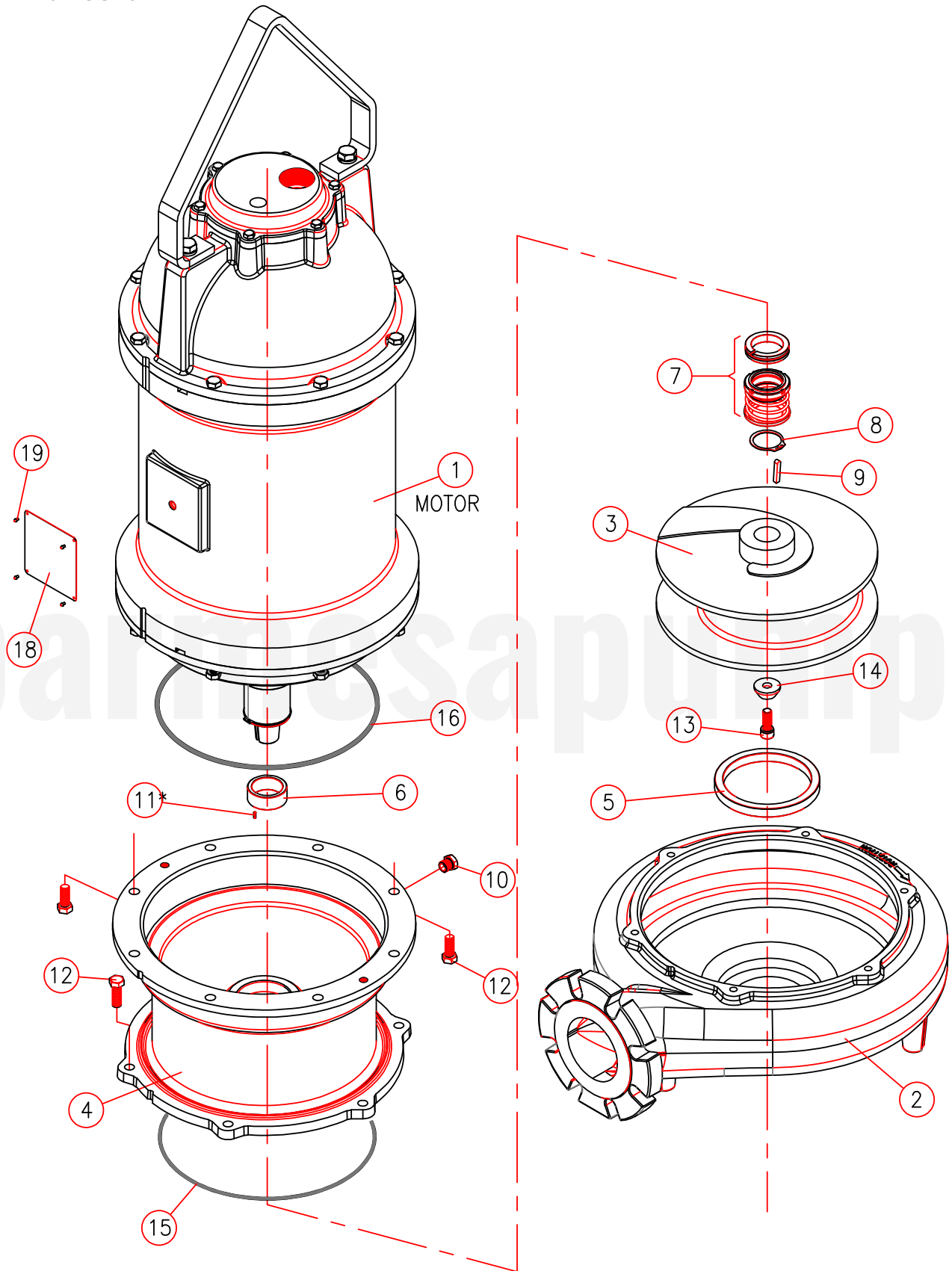

For repair part please supply: model number and serial as shown on name plate, and part description and part number as shown on parts list.

## ▶ 4SWM frame 320

Item	Part Number	Description	Qty.	Material
1	40043019	Motor Frame 320, 50 hp - 1750 rpm	1	N/A
2	03090109	Volute	1	Cast Iron, Class 30
3	03140242	Impeller 12.60"Ø, 50 hp, 1750 rpm	1	Ductile Iron, 65-45-12
4	03180039	Seal Plate	1	Cast Iron, Class 30
5	30400374	Wear Ring Volute 4SWM/H	1	Bronze C954
6	30400624K	Bearing Sleeve 320	1	Bronze SAE 40
7	31030139Q	Mechanical Seal Outer 2.625"Ø Type 21, Seal with O-Ring slotted	1	Sic / Sic / Buna / SS
8	31010015K	Retaining Ring # 5100-262 SS	1	420 SS
9	30400639	Key ¼" x ¼" x 1½" SS	1	304 SS
10	93010131	Hex Head Plug 3/8" SS # 22932	1	304 SS
11	91010184C	Roll Pin 1/8"Ø x ½" SS	1	420 SS
12	91010351	Screw Hex. Head ½" x 1½" SS	14	18-8 SS
13	91010334B	Socket Head Screw ½"-20UNF x 1¼" lg.	1	304 SS
14	30400413	Impeller Washer SS	1	304 SS
15	92010064G	O-Ring # 280, Volute	1	Buna N
16	92010064F	O-Ring # 279, Seal Plate	1	Buna N
17	31010031	Motor Oil (Seal's Plate Cavity)	7 lt.	N/A
18	94010074	Nameplate	1	304 SS
19	91010192	Rivet SS # 001628	4	Stainless Steel

For repair part please supply: model number and serial as shown on name plate, and part description and part number as shown on parts list.

► 4SWM frame 320

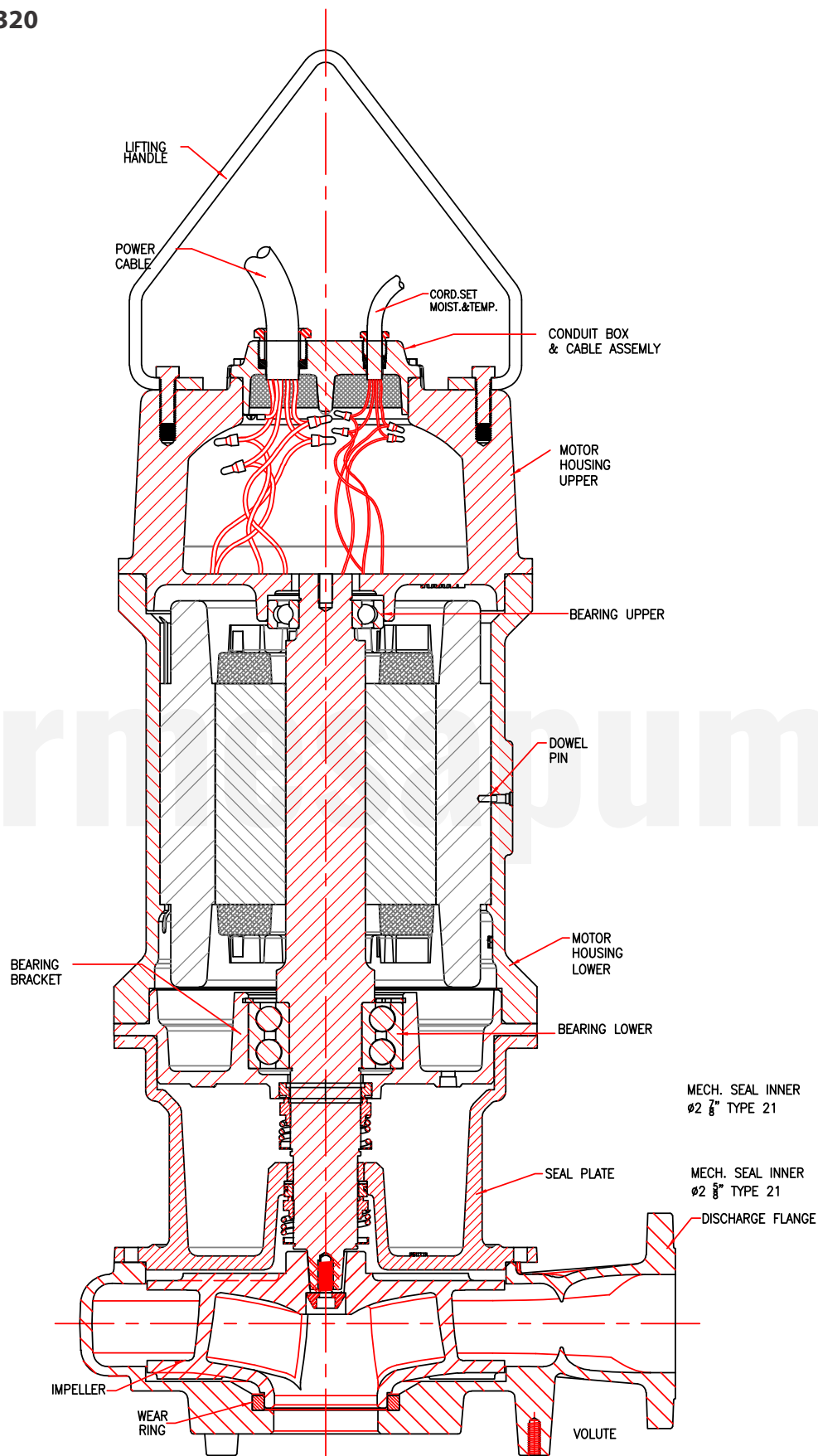

For repair part please supply: model number and serial as shown on name plate, and part description and part number as shown on parts list.

► 4SWH frame 250

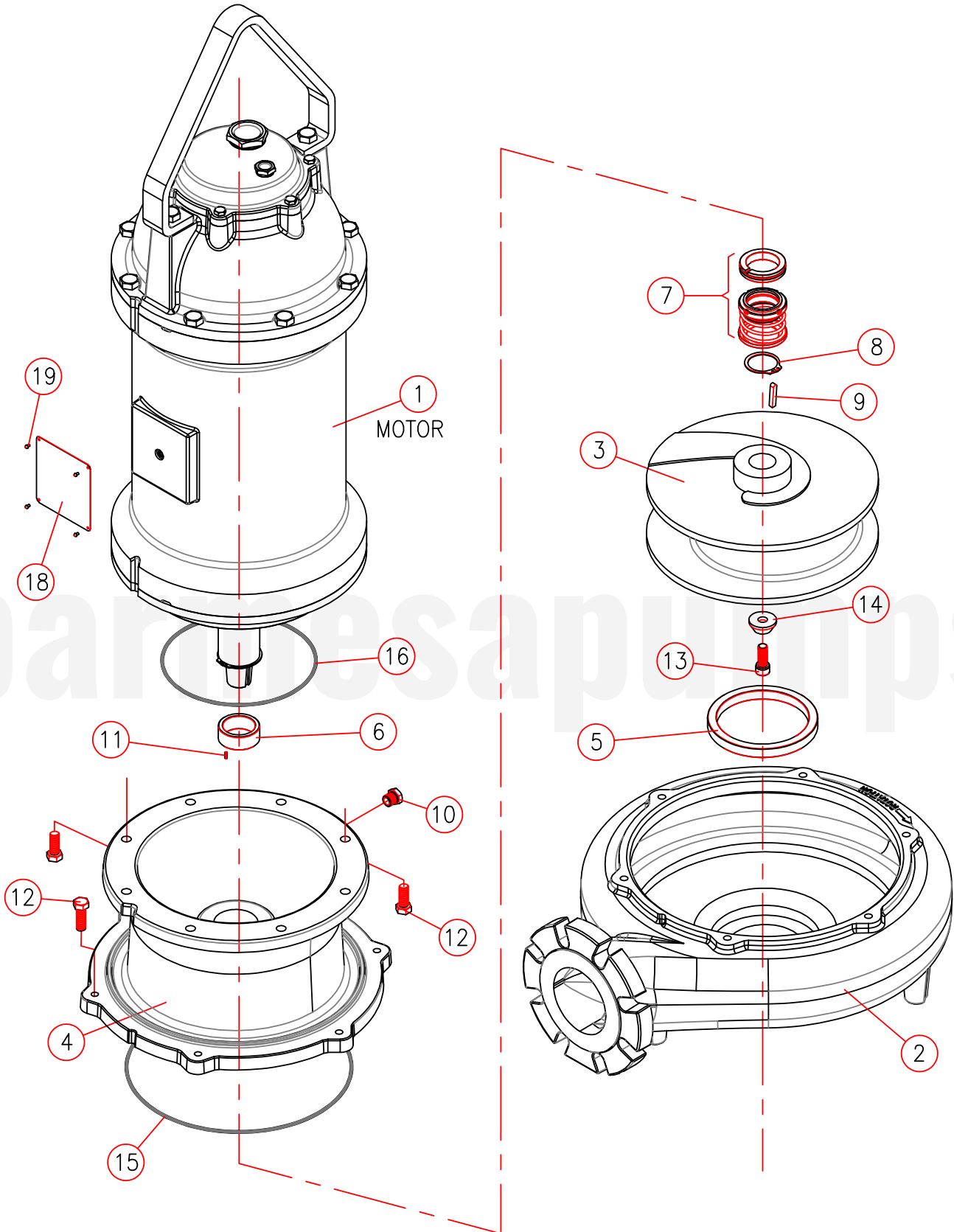

For repair part please supply: model number and serial as shown on name plate, and part description and part number as shown on parts list.

## ► 4SWH frame 250

Item	Part Number	Description	Qty.	Material
1	40043013	Motor Frame 250, 20 hp - 1750 rpm	1	N/A
	40043013	Motor Frame 250, 25 hp - 1750 rpm		
	40043015	Motor Frame 250, 30 hp - 1750 rpm		
	40043017	Motor Frame 250, 40 hp - 1750 rpm		
	40043030	Motor Frame 250, 10 hp - 1150 rpm		
	40043032	Motor Frame 250, 15 hp - 1150 rpm		
	40043032	Motor Frame 250, 20 hp - 1150 rpm		
	40043034	Motor Frame 250, 25 hp - 1150 rpm		
	40043036	Motor Frame 250, 30 hp - 1150 rpm		
	40043038	Motor Frame 250, 40 hp - 1150 rpm		
2	03090109	Volute	1	Cast Iron, Class 30
3	03140243	Impeller 14.57"Ø, 40 hp, 1150 rpm	1	Ductil Iron, 65-45-12
	03140243B	Impeller 13.98"Ø, 30 hp, 1150 rpm		
	03140243C	Impeller 13.19"Ø, 25 hp, 1150 rpm		
	03140243F	Impeller 12.21"Ø, 20 hp, 1150 rpm		
	03140243H	Impeller 11.02"Ø, 40 hp, 1750 rpm		
	03140243H	Impeller 11.02"Ø, 15 hp, 1150 rpm		
	03140243K	Impeller 9.84"Ø, 10 hp, 1150 rpm		
	03140243L	Impeller 9.65"Ø, 25 hp, 1750 rpm		
	03140243M	Impeller 9.25"Ø, 20 hp, 1750 rpm		
4	03180038	Seal Plate	1	Cast Iron, Class 30
5	30400374	Wear Ring Volute 4SWM/H	1	Bronze C954
6	30400624H	Bearing Sleeve 250	1	Bronze SAE 40
7	31030139K	Mechanical Seal Outer 2.250"Ø Type 21, Seal with O-Ring slotted	1	Sic / Sic / Buna / SS
8	31010010	Retaining Ring # 5100-225 SS	1	420 SS
9	30400639	Key ¼" x ¼" x 1½" SS	1	304 SS
10	93010131	Hex Head Plug 3/8" SS # 22932	1	304 SS
11	91010184C	Roll Pin 1/8"Ø x ½" SS	1	420 SS
12	91010364	Screw Hex. Head ½" x 1.75" SS	8	18-8 SS
12.1	91010351	Screw Hex. Head ½" x 1½" SS	6	18-8 SS
13	91010334B	Socket Head Screw ½"-20UNF x 1¼" lg.	1	304 SS
14	30400413	Impeller Washer SS	1	304 SS
15	92010064G	O-Ring # 280, Volute	1	Buna N
16	92010089	O-Ring # 275, Seal Plate	1	Buna N
17	31010031	Motor Oil (Seal's Plate Cavity)	5.5 lt.	N/A
18	94010074	Nameplate	1	304 SS
19	91010192	Rivet SS # 001628	4	Stainless Steel

For repair part please supply: model number and serial as shown on name plate, and part description and part number as shown on parts list.

► 4SWH frame 250

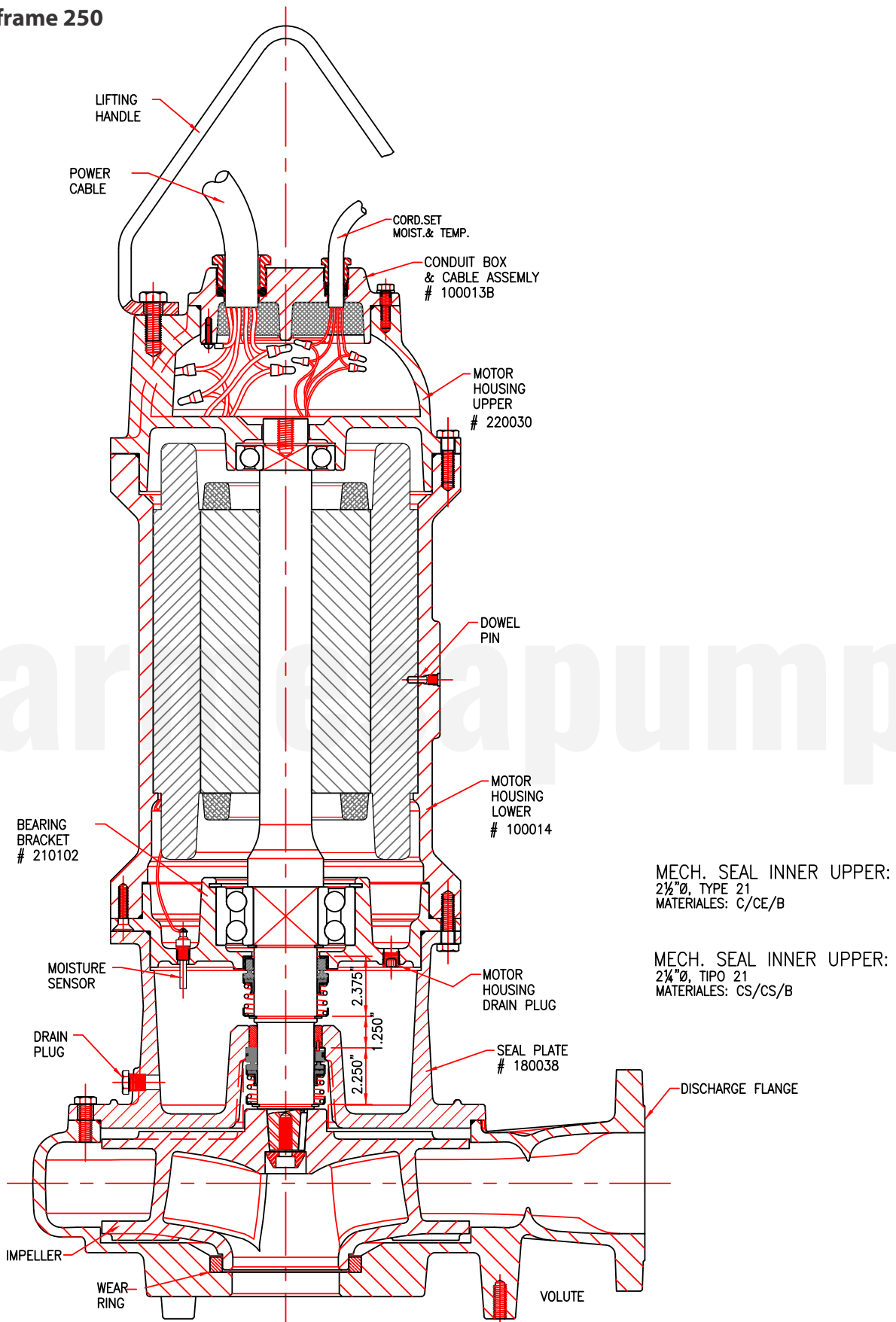

MECH. SEAL INNER UPPER:  
 $2\frac{1}{2}''\varnothing$ , TYPE 21  
 MATERIALES: C/CE/B

MECH. SEAL INNER UPPER:  
 $2\frac{1}{4}''\varnothing$ , TIPO 21  
 MATERIALES: CS/CS/B

For repair part please supply: model number and serial as shown on name plate, and part description and part number as shown on parts list.



► 4SWH frame 320

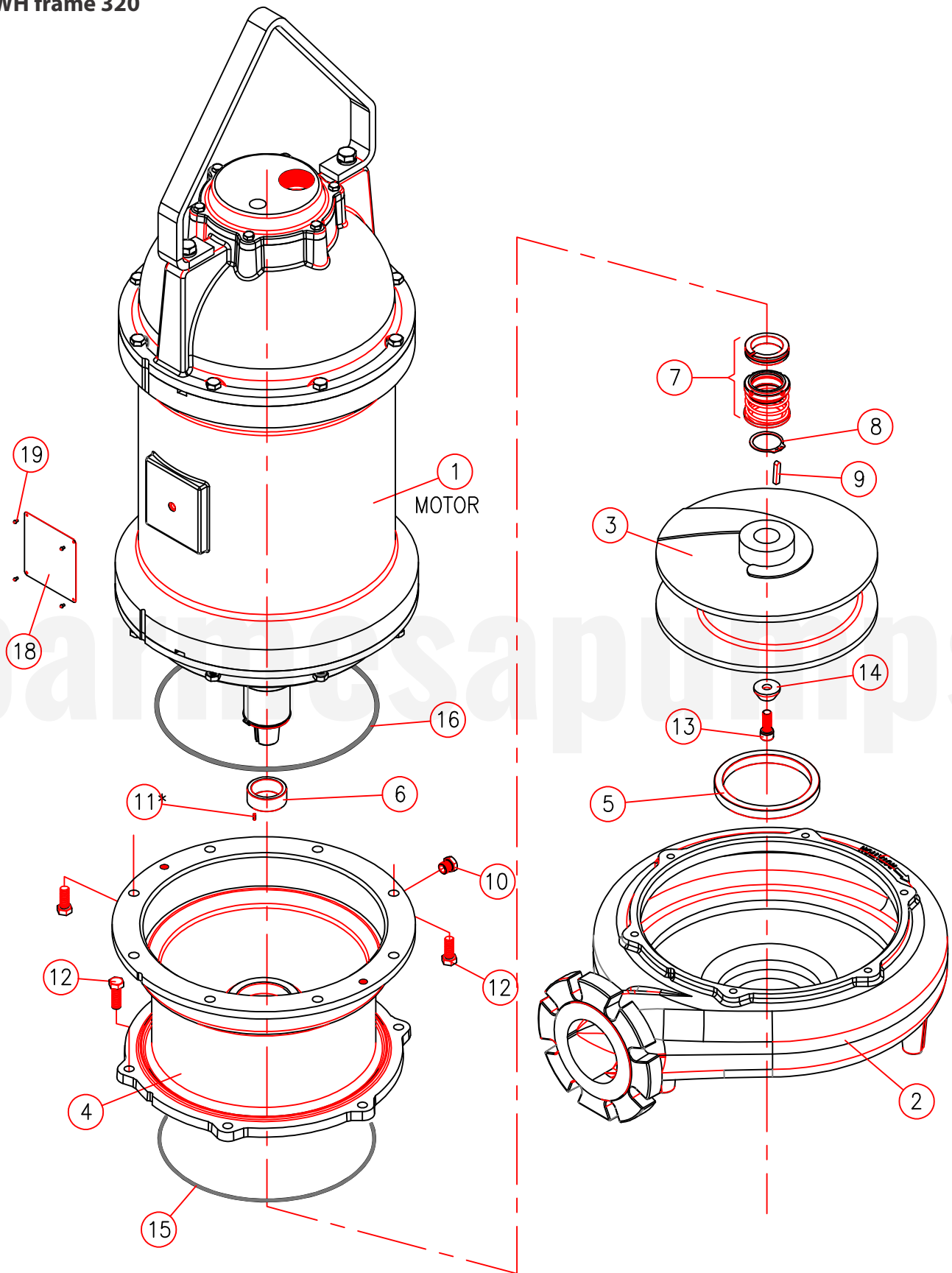

For repair part please supply: model number and serial as shown on name plate, and part description and part number as shown on parts list.

## ► 4SWH frame 320

Item	Part Number	Description	Qty.	Material
1	40043019	Motor Frame 320, 50 hp - 1750 rpm	1	N/A
	40043021	Motor Frame 320, 60 hp - 1750 rpm		
	40043023	Motor Frame 320, 75 hp - 1750 rpm		
	40040382	Motor Frame 320, 25 hp - 1150 rpm		
	40043036	Motor Frame 320, 30 hp - 1150 rpm		
	40043038	Motor Frame 320, 40 hp - 1150 rpm		
2	03090109	Volute	1	Cast Iron, Class 30
3	03140243D	Impeller 12.99"Ø, 75 hp, 1750 rpm	1	Ductile Iron, 65-45-12
	03140243E	Impeller 12.40"Ø, 60 hp, 1750 rpm		
	03140243G	Impeller 11.61"Ø, 50 hp, 1750 rpm		
	03140243C	Impeller 13.19"Ø, 25 hp, 1150 rpm		
	03140243B	Impeller 13.98"Ø, 30 hp, 1150 rpm		
	03140243	Impeller 14.57"Ø, 40 hp, 1150 rpm		
4	03180039	Seal Plate	1	Cast Iron, Class 30
5	30400374	Wear Ring Volute 4SWM/H	1	Bronze C954
6	30400624K	Bearing Sleeve 320	1	Bronze SAE 40
7	31030139Q	Mechanical Seal Outer 2.625"Ø Type 21, Seal with O-Ring slotted	1	Sic / Sic / Buna / SS
8	31010015K	Retaining Ring # 5100-262 SS	1	420 SS
9	30400639	Key ¼" x ¼" x 1½" SS	1	304 SS
10	93010131	Hex Head Plug 3/8" SS # 22932	1	304 SS
11	91010184C	Roll Pin 1/8"Ø x ½" SS	1	420 SS
12	91010351	Screw Hex. Head ½" x 1½" SS	14	18-8 SS
13	91010334B	Socket Head Screw ½"-20UNF x 1¼" lg.	1	304 SS
14	30400413	Impeller Washer SS	1	304 SS
15	92010064G	O-Ring # 280, Volute	1	Buna N
16	92010064F	O-Ring # 279, Seal Plate	1	Buna N
17	31010031	Motor Oil (Seal's Plate Cavity)	7 lt.	N/A
18	94010074	Nameplate	1	304 SS
19	91010192	Rivet SS # 001628	4	Stainless Steel

For repair part please supply: model number and serial as shown on name plate, and part description and part number as shown on parts list.

► 4SWH frame 320

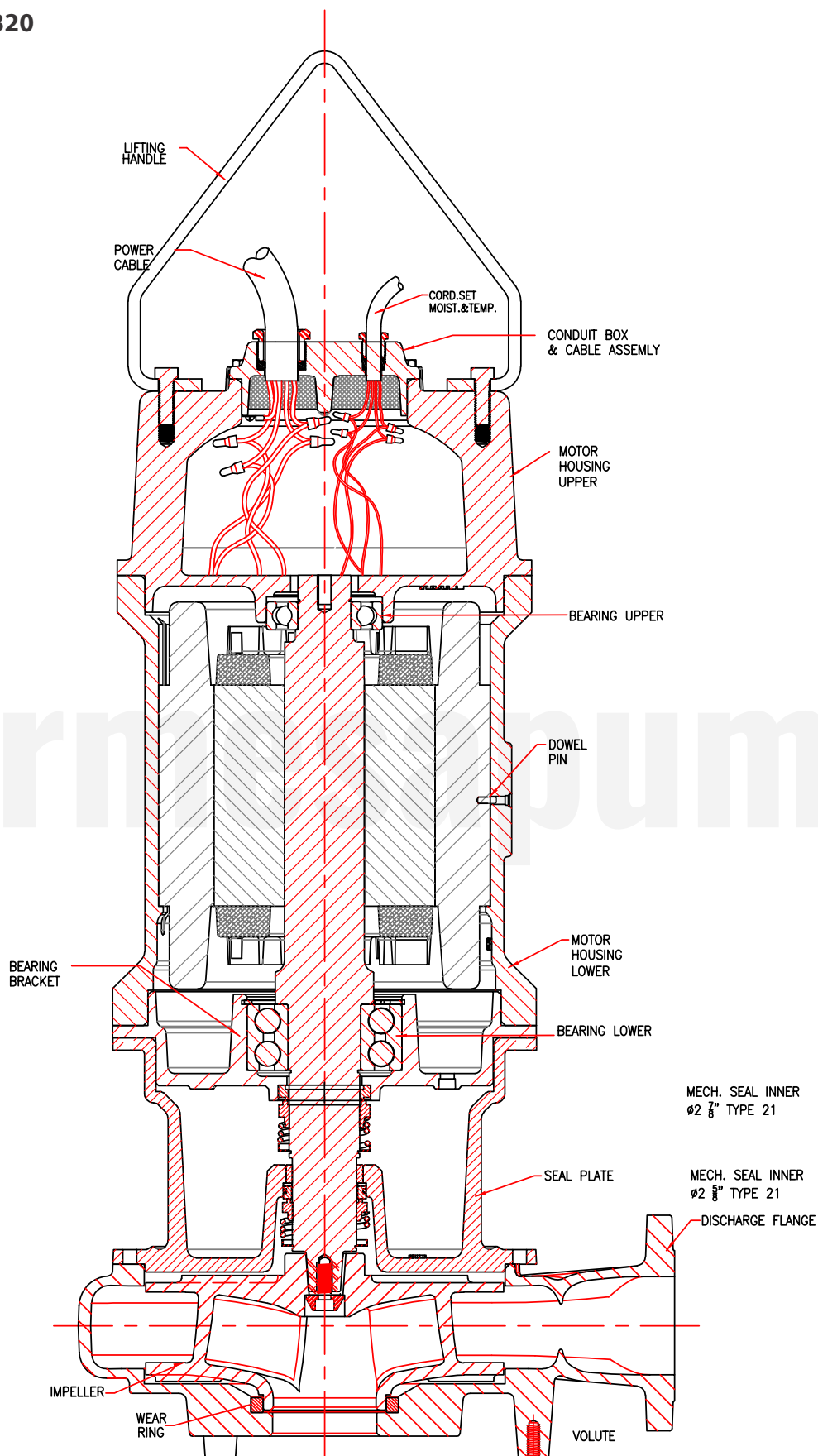

For repair part please supply: model number and serial as shown on name plate, and part description and part number as shown on parts list.

► 6SWL frame 210

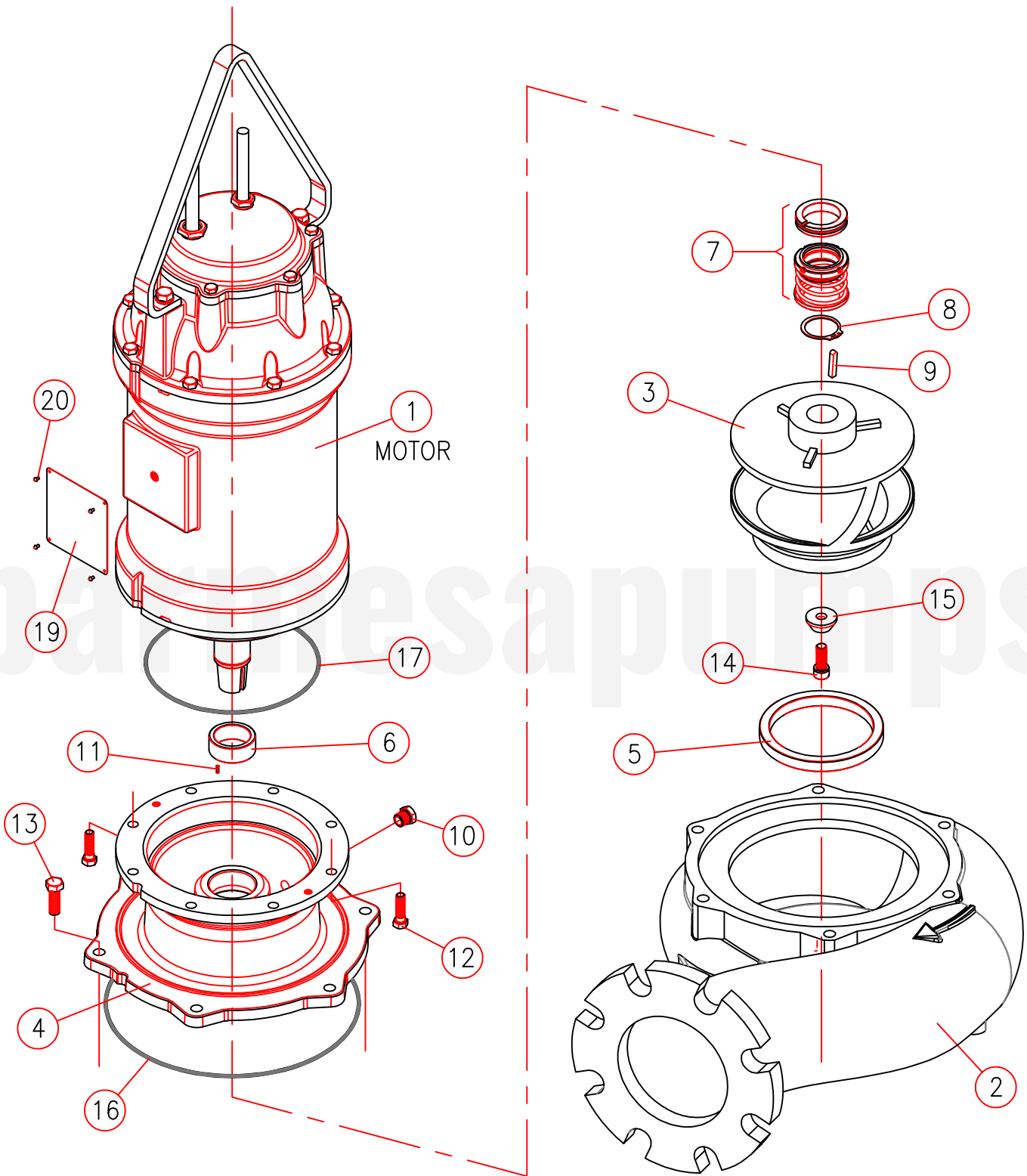

For repair part please supply: model number and serial as shown on name plate, and part description and part number as shown on parts list.

## ▶ 6SWL frame 210

Item	Part Number	Description	Qty.	Material
1	40043011	Motor Frame 210, 15 hp - 1750 rpm	1	
2	03090110	Volute	1	Cast Iron, Class 30
3	03140244C	Impeller 8.07" ,15hp, 1750 rpm	1	Ductile Iron, 65-45-12
4	03180036	Seal Plate	1	Cast Iron, Class 30
5	30400375	Wear Ring Volute 6SWL	1	Bronze C954
6	30400624G	Bearing Sleeve 210	1	Bronze SAE 40
7	31030290E	Mechanical Seal Outer 1.750"Ø Type 21, Seal with O-Ring slotted	1	Sic / Sic / Buna / SS
8	31010008C	Retaining Ring # 5100-175 SS	1	420 SS
9	30400639	Key ¼" x ¼" x 1½" SS	1	304 SS
10	93010131	Hex Head Plug 3/8" SS # 22932	1	304 SS
11	91010184C	Roll Pin 1/8"Ø x ½" SS	1	420 SS
12	91010348E	Screw Hex. Head 7/16" x 2.00" SS	8	18-8 SS
13	91010351	Screw Hex. Head ½" x 1½" SS	6	18-8 SS
14	91010334B	Socket Head Screw ½"-20UNF x 1¼" lg.	1	304 SS
15	30400413	Impeller Washer SS	1	304 SS
16	92010064E	O-Ring # 278, Volute	1	Buna N
17	92010089	O-Ring # 275, Seal Plate	1	Buna N
18	31010031	Motor Oil (Seal's Plate Cavity)	3 lts.	
19	94010074	Nameplate	1	304 SS
20	91010192	Rivet SS # 001628	4	Stainless Steel

For repair part please supply: model number and serial as shown on name plate, and part description and part number as shown on parts list.

► 6SWL frame 210

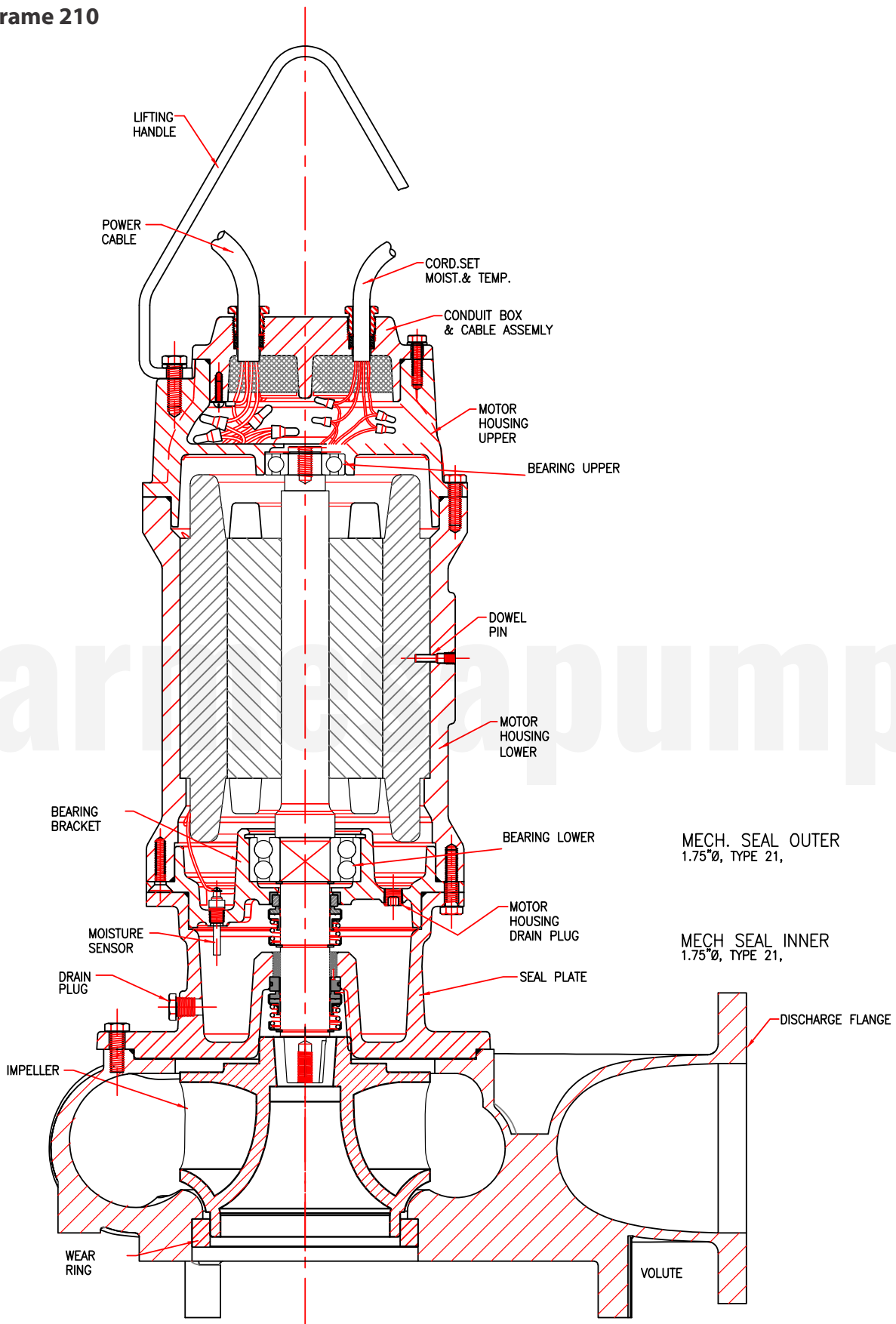

For repair part please supply: model number and serial as shown on name plate, and part description and part number as shown on parts list.

► 6SWL frame 250

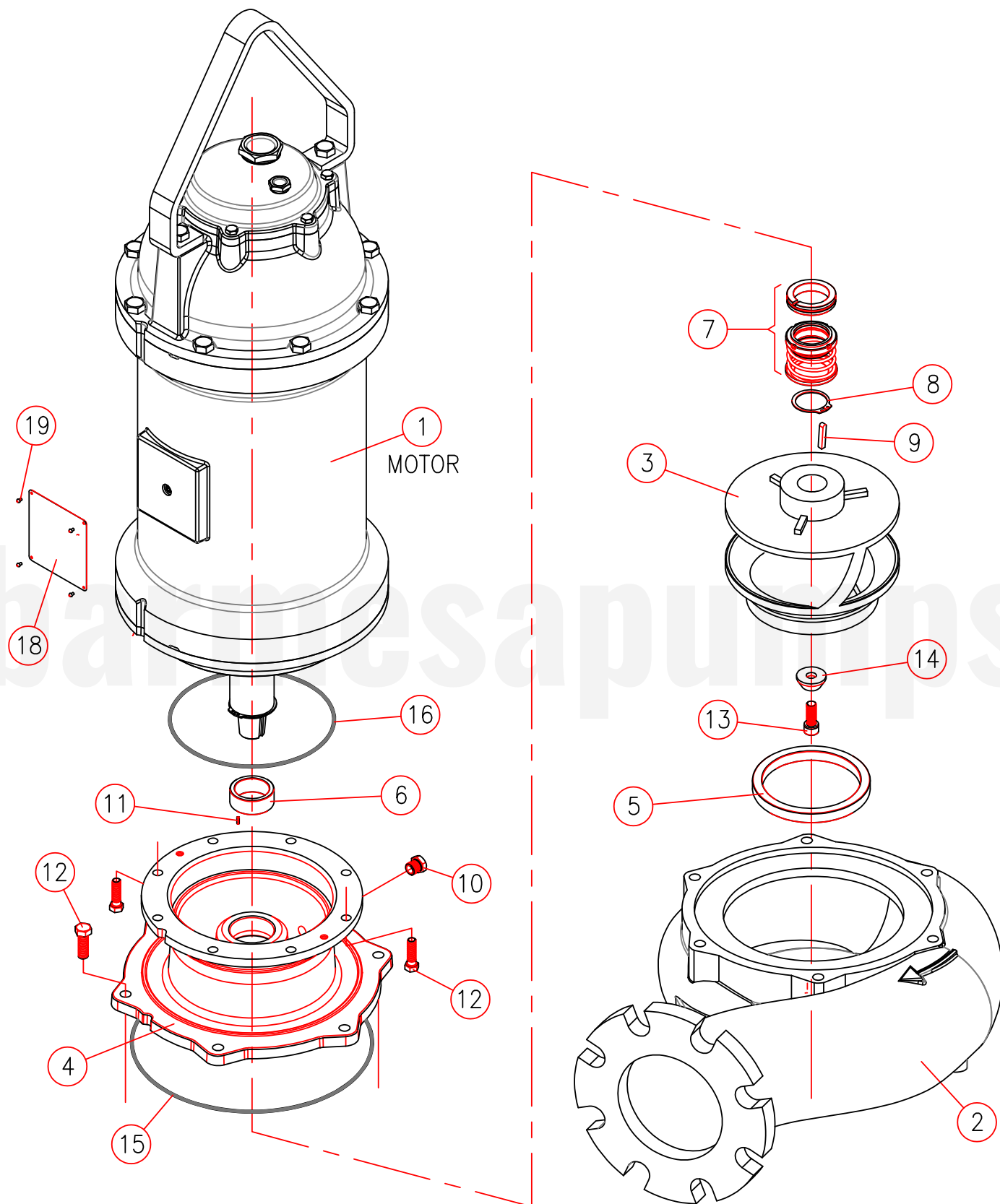

For repair part please supply: model number and serial as shown on name plate, and part description and part number as shown on parts list.



## ► 6SWL frame 250

Item	Part Number	Description	Qty.	Material
1	40043030	Motor Frame 250, 7.5 hp - 1150 rpm	1	
	40043030	Motor Frame 250, 10 hp - 1150 rpm		
	40043013	Motor Frame 250, 20 hp - 1750 rpm		
	40043013	Motor Frame 250, 25 hp - 1750 rpm		
2	03090110	Volute	1	Cast Iron, Class 30
3	03140244	Impeller 8.85" ,25hp, 1750 rpm	1	Ductile Iron, 65-45-12
		Impeller 8.85" ,10hp, 1150 rpm		
	03140244A	Impeller 8.66" ,7.5hp, 1150 rpm		
	03140244B	Impeller 8.47" ,20hp, 1750 rpm		
4	03180037	Seal Plate	1	Cast Iron, Class 30
5	30400375	Wear Ring Volute 6SWL	1	Bronze C954
6	30400624H	Bearing Sleeve 250	1	Bronze SAE 40
7	31030290E	Mechanical Seal Outer 1.750"Ø Type 21, Seal with O-Ring slotted	1	Sic / Sic / Buna / SS
8	31010008C	Retaining Ring # 5100-175 SS	1	420 SS
9	30400639	Key ¼" x ¼" x 1½" SS	1	304 SS
10	93010131	Hex Head Plug 3/8" SS # 22932	1	304 SS
11	91010184C	Roll Pin 1/8"Ø x ½" SS	1	420 SS
12	91010351	Screw Hex. Head ½" x 1½" SS	14	18-8 SS
13	91010334B	Socket Head Screw ½"-20UNF x 1¼" lg.	1	304 SS
14	30400413	Impeller Washer SS	1	304 SS
15	92010064E	O-Ring # 278, Volute	1	Buna N
16	92010089	O-Ring # 275, Seal Plate	1	Buna N
17	31010031	Motor Oil (Seal's Plate Cavity)	3 lts.	
18	94010074	Nameplate	1	304 SS
19	91010192	Rivet SS # 001628	4	Stainless Steel

For repair part please supply: model number and serial as shown on name plate, and part description and part number as shown on parts list.

► 6SWL frame 250

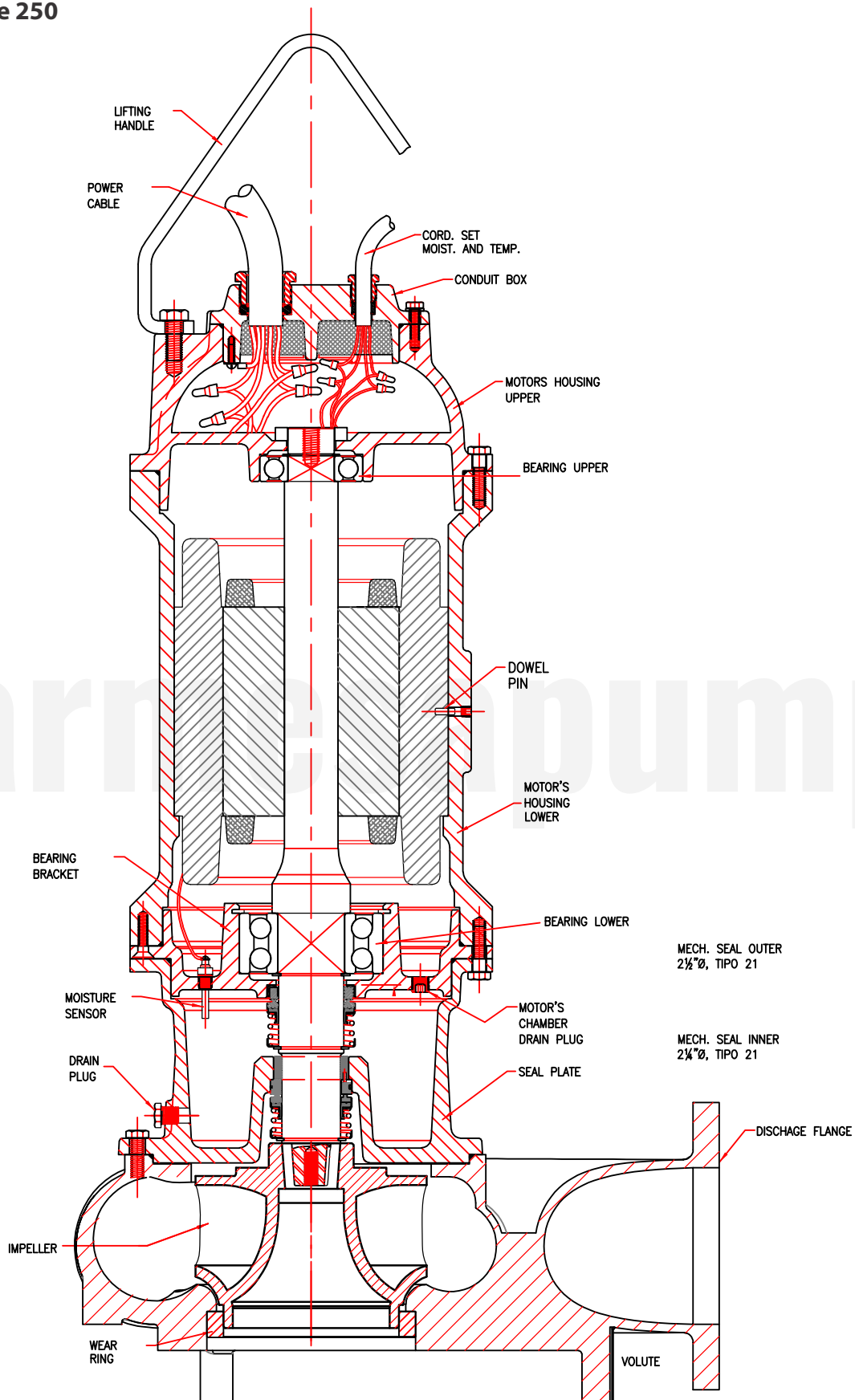

For repair part please supply: model number and serial as shown on name plate, and part description and part number as shown on parts list.

► 6SWM frame 250

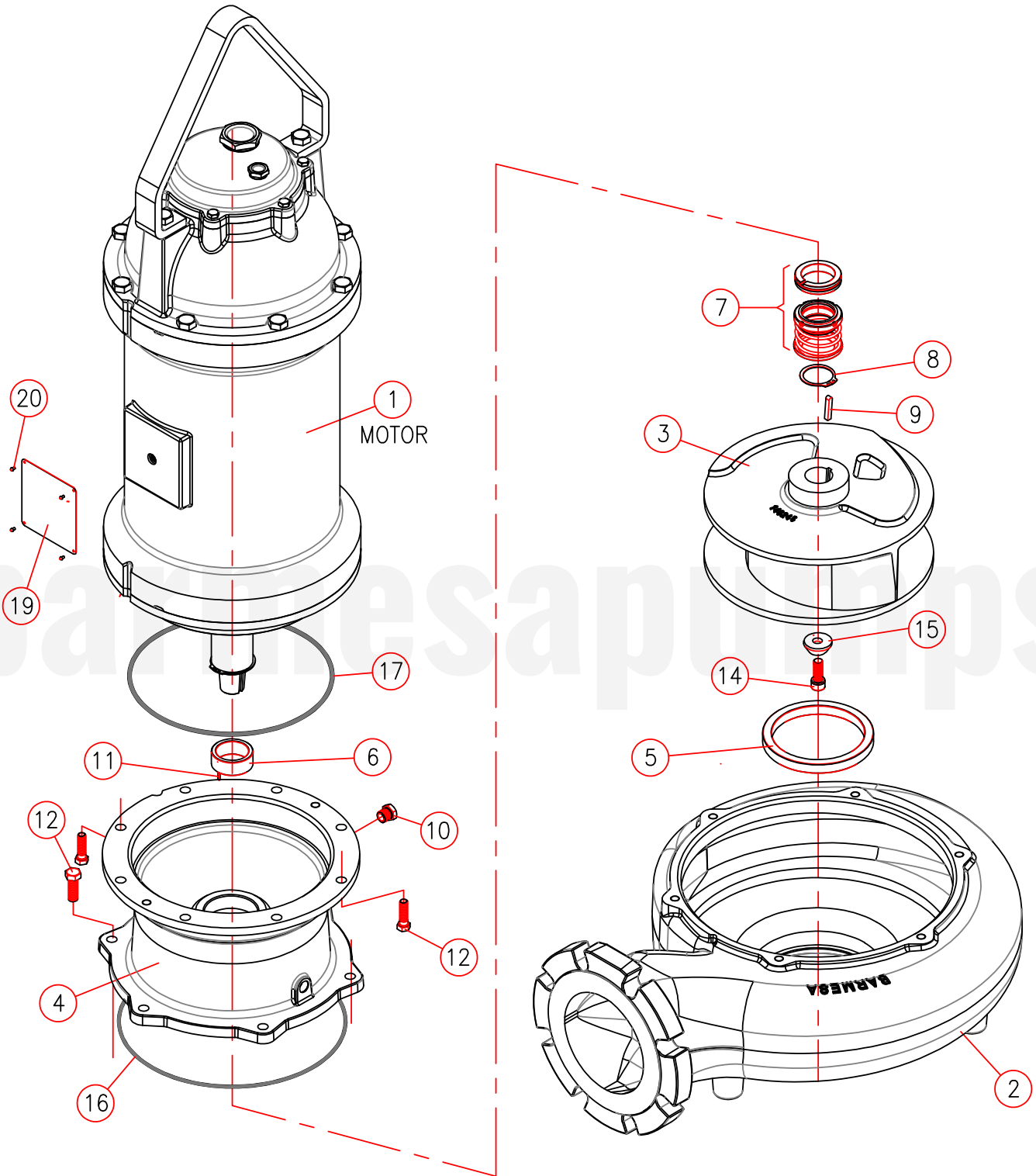

For repair part please supply: model number and serial as shown on name plate, and part description and part number as shown on parts list.

## ► 6SWM frame 250

Item	Part Number	Description	Qty.	Material
1	40043013	Motor Frame 250, 20 hp - 1750 rpm	1	
	40043013	Motor Frame 250, 25 hp - 1750 rpm		
	40043015	Motor Frame 250, 30 hp - 1750 rpm		
	40043017	Motor Frame 250, 40 hp - 1750 rpm		
	40043030	Motor Frame 250, 7.5 hp - 1150 rpm		
	40043030	Motor Frame 250, 10 hp - 1150 rpm		
	40043032	Motor Frame 250, 15 hp - 1150 rpm		
2	03090108	Volute	1	Cast Iron, Class 30
3	03140245	Impeller 12.40"Ø, 15 hp, 1150 rpm	1	Ductile Iron, 65-45-12
	03140245C	Impeller 11.22"Ø, 40 hp, 1750 rpm		
	03140245D	Impeller 11.02"Ø, 10 hp, 1150 rpm		
	03140245E	Impeller 10.63"Ø, 30 hp, 1750 rpm		
	03140245F	Impeller 10.04"Ø, 25 hp, 1750 rpm		
4	03180038	Seal Plate	1	Cast Iron, Class 30
5	30400376	Wear Ring Volute 6SWM	1	Bronze C954
6	30400624H	Bearing Sleeve 250	1	Bronze SAE 40
7	31030290E	Mechanical Seal Outer 1.750"Ø Type 21, Seal with O-Ring slotted	1	Sic / Sic / Buna / SS
8	31010008C	Retaining Ring # 5100-175 SS	1	420 SS
9	30400639	Key ¼" x ¼" x 1½" SS	1	304 SS
10	93010131	Hex Head Plug 3/8" SS # 22932	1	304 SS
11	91010184C	Roll Pin 1/8"Ø x ½" SS	1	420 SS
12	91010351	Screw Hex. Head ½" x 1½" SS	14	18-8 SS
13	91010334B	Socket Head Screw ½"-20UNF x 1¼" lg.	1	304 SS
14	30400413	Impeller Washer SS	1	304 SS
15	92010064G	O-Ring # 280, Volute	1	Buna N
16	92010089	O-Ring # 275, Seal Plate	1	Buna N
17	31010031	Motor Oil (Seal's Plate Cavity)	3 lts.	
18	94010074	Nameplate	1	304 SS
19	91010192	Rivet SS # 001628	4	Stainless Steel

For repair part please supply: model number and serial as shown on name plate, and part description and part number as shown on parts list.

► 6SWM frame 250

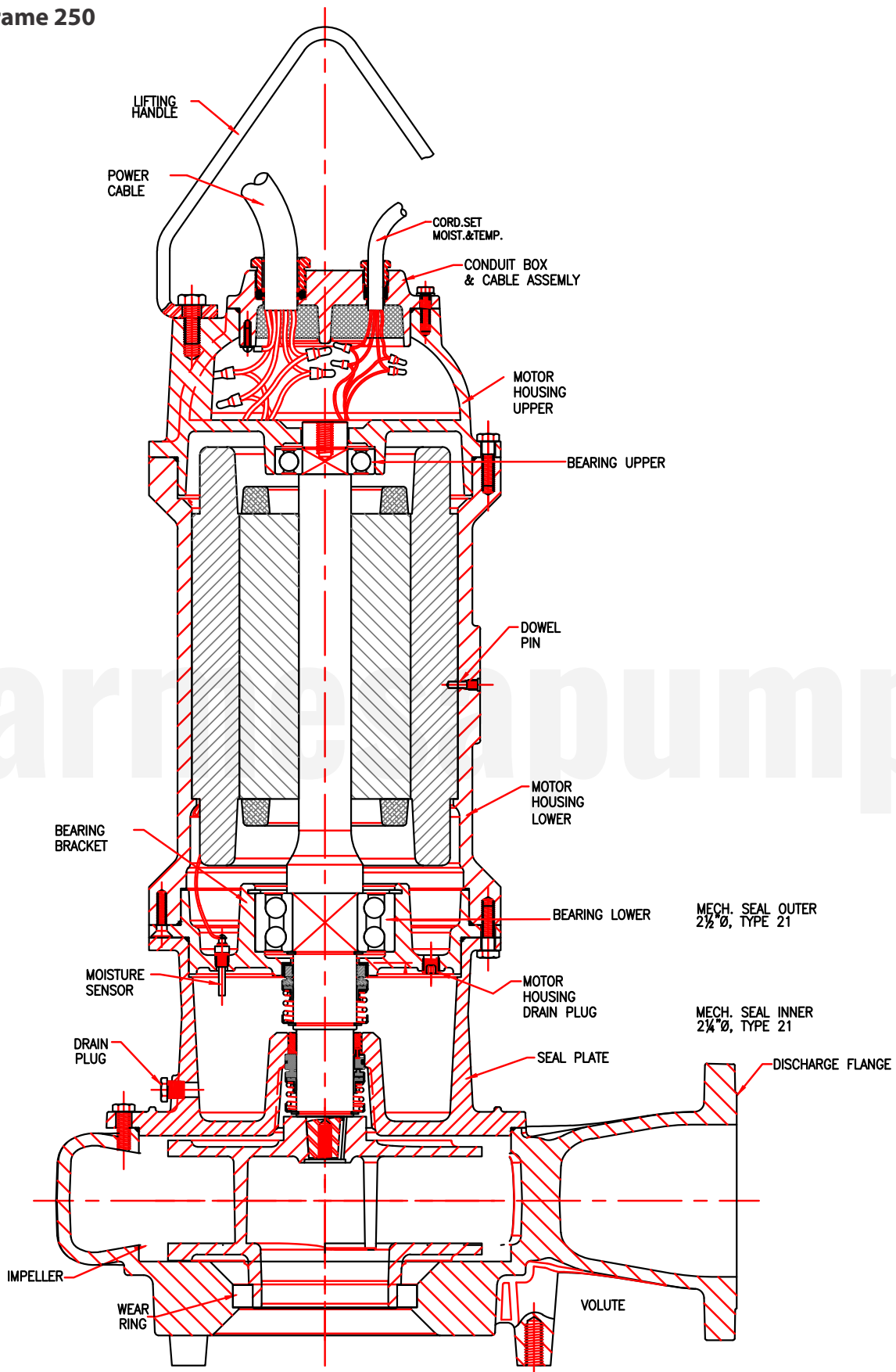

For repair part please supply: model number and serial as shown on name plate, and part description and part number as shown on parts list.

► 6SWM frame 320

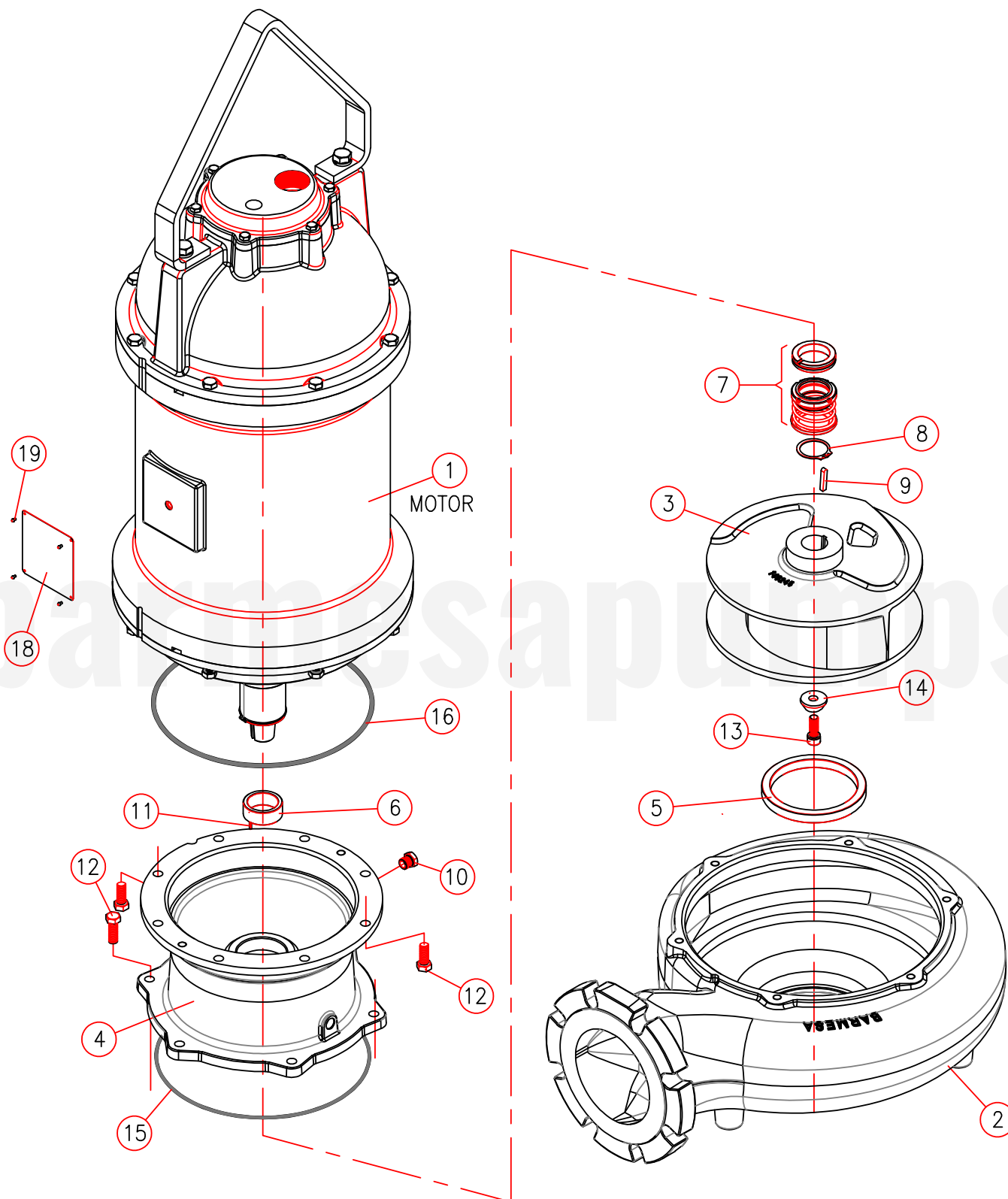

For repair part please supply: model number and serial as shown on name plate, and part description and part number as shown on parts list.

## ▶ 6SWM frame 320

Item	Part Number	Description	Qty.	Material
1	40043019	Motor Frame 320, 50 hp - 1750 rpm	1	N/A
2	03090108	Volute	1	Cast Iron, Class 30
3	03140245B	Impeller 12.00"Ø, 50 hp, 1750 rpm	1	Ductile Iron, 65-45-12
4	03180039	Seal Plate	1	Cast Iron, Class 30
5	30400376	Wear Ring Volute 6SWM	1	Bronze C954
6	30400624K	Bearing Sleeve 320	1	Bronze SAE 40
7	31030139Q	Mechanical Seal Outer 2.625"Ø Type 21, Seal with O-Ring slotted	1	Sic / Sic / Buna / SS
8	31010008K	Retaining Ring # 5100-262 SS	1	420 SS
9	30400639	Key ¼" x ¼" x 1½" SS	1	304 SS
10	93010131	Hex Head Plug 3/8" SS # 22932	1	304 SS
11	91010184C	Roll Pin 1/8"Ø x ½" SS	1	420 SS
12	91010351	Screw Hex. Head ½" x 1½" SS	14	18-8 SS
13	91010334B	Socket Head Screw ½"-20UNF x 1¼" lg.	1	304 SS
14	30400413	Impeller Washer SS	1	304 SS
15	92010064G	O-Ring # 280, Volute	1	Buna N
16	92010064F	O-Ring # 279, Seal Plate	1	Buna N
17	31010031	Motor Oil (Seal's Plate Cavity)	7 lts.	
18	94010074	Nameplate	1	304 SS
19	91010192	Rivet SS # 001628	4	Stainless Steel

For repair part please supply: model number and serial as shown on name plate, and part description and part number as shown on parts list.



## ▶ 6SWM frame 320

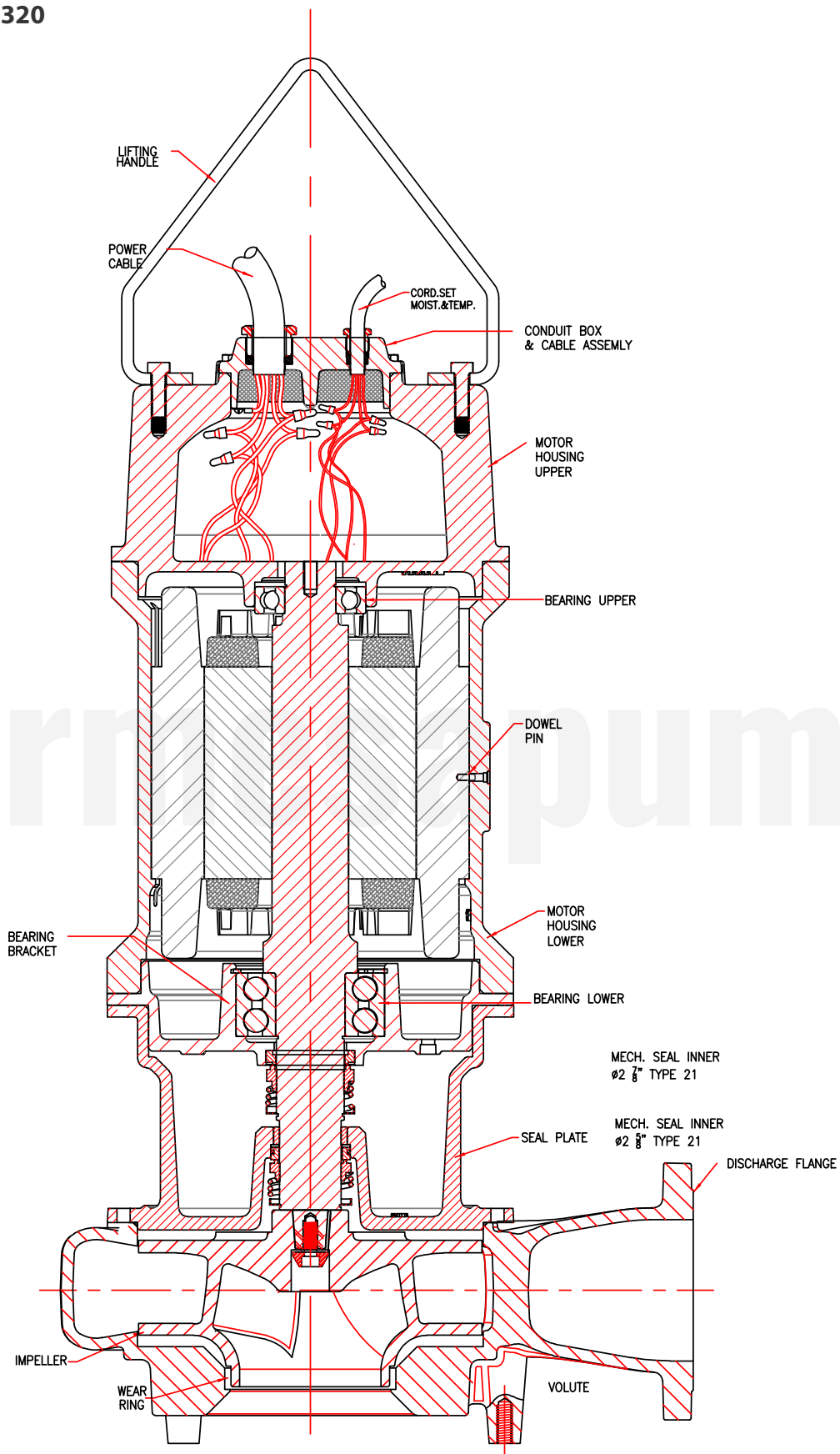

For repair part please supply: model number and serial as shown on name plate, and part description and part number as shown on parts list.

► 6SWH frame 250

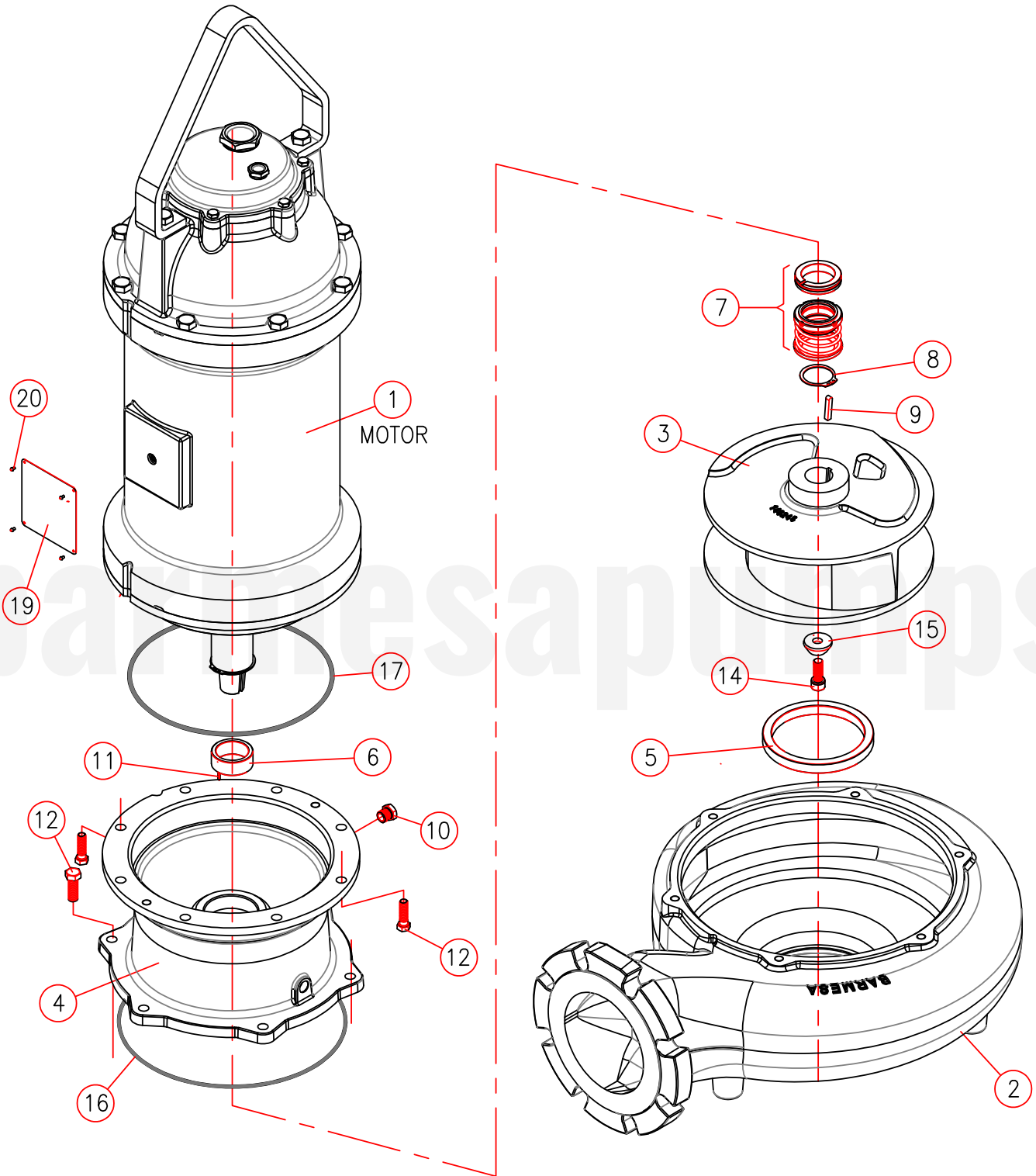

For repair part please supply: model number and serial as shown on name plate, and part description and part number as shown on parts list.

## ► 6SWH frame 250

Item	Part Number	Description	Qty.	Material
1	40043013	Motor Frame 250, 20 hp - 1750 rpm	1	
	40043013	Motor Frame 250, 25 hp - 1750 rpm		
	40043015	Motor Frame 250, 30 hp - 1750 rpm		
	40043017	Motor Frame 250, 40 hp - 1750 rpm		
	40043030	Motor Frame 250, 7.5 hp - 1150 rpm		
	40043030	Motor Frame 250, 10 hp - 1150 rpm		
	40043032	Motor Frame 250, 15 hp - 1150 rpm		
	40043032	Motor Frame 250, 20 hp - 1150 rpm		
	40043034	Motor Frame 250, 25 hp - 1150 rpm		
	40043036	Motor Frame 250, 30 hp - 1150 rpm		
	40043038	Motor Frame 250, 40 hp - 1150 rpm		
2	03090108	Volute	1	Cast Iron, Class 30
3	03140246	Impeller 14.57"Ø, 40 hp, 1150 rpm	1	Ductile Iron, 65-45-12
	03140246B	Impeller 14.14"Ø, 30 hp, 1150 rpm		
	03140246D	Impeller 13.78"Ø, 25 hp, 1150 rpm		
	03140246E	Impeller 13.19"Ø, 20 hp, 1150 rpm		
	03140246G	Impeller 12.21"Ø, 15 hp, 1150 rpm		
	03140246J	Impeller 11.02"Ø, 40 hp, 1750 rpm		
	03140246K	Impeller 10.43"Ø, 10 hp, 1150 rpm		
	03140246L	Impeller 10.04"Ø, 30 hp, 1750 rpm		
	03140246M	Impeller 9.45"Ø, 25 hp, 1750 rpm		
	03140246N	Impeller 9.25"Ø, 7.5 hp, 1150 rpm		
4	03180038	Seal Plate	1	Cast Iron, Class 30
5	30400377	Wear Ring Volute 6SWH	1	Bronze C954
6	30400624H	Bearing Sleeve 250	1	Bronze SAE 40
7	31030290E	Mechanical Seal Outer 1.750"Ø Type 21, Seal with O-Ring slotted	1	Sic / Sic / Buna / SS
8	31010008C	Retaining Ring # 5100-175 SS	1	420 SS
9	30400639	Key ¼" x ¼" x 1½" SS	1	304 SS
10	93010131	Hex Head Plug 3/8" SS # 22932	1	304 SS
11	91010184C	Roll Pin 1/8"Ø x ½" SS	1	420 SS
12	91010351	Screw Hex. Head ½" x 1½" SS	14	18-8 SS
13	91010334B	Socket Head Screw ½"-20UNF x 1¼" lg.	1	304 SS
14	30400413	Impeller Washer SS	1	304 SS
15	92010064G	O-Ring # 280, Volute	1	Buna N
16	92010089	O-Ring # 275, Seal Plate	1	Buna N
17	31010031	Motor Oil (Seal's Plate Cavity)	3 lts.	
18	94010074	Nameplate	1	304 SS
19	91010192	Rivet SS # 001628	4	Stainless Steel

For repair part please supply: model number and serial as shown on name plate, and part description and part number as shown on parts list.

## ▶ 6SWH frame 250

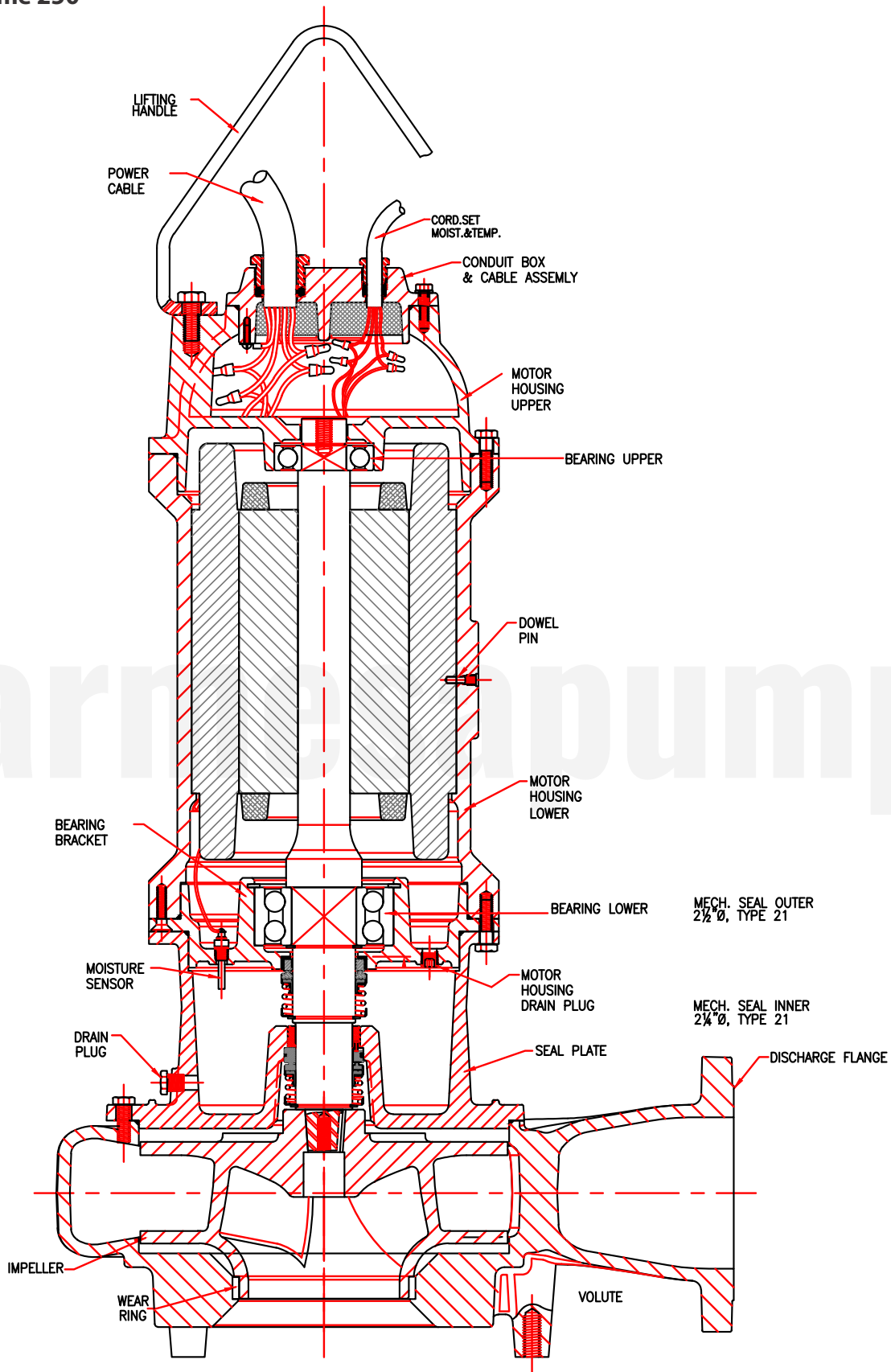

For repair part please supply: model number and serial as shown on name plate, and part description and part number as shown on parts list.

► 6SWH frame 320

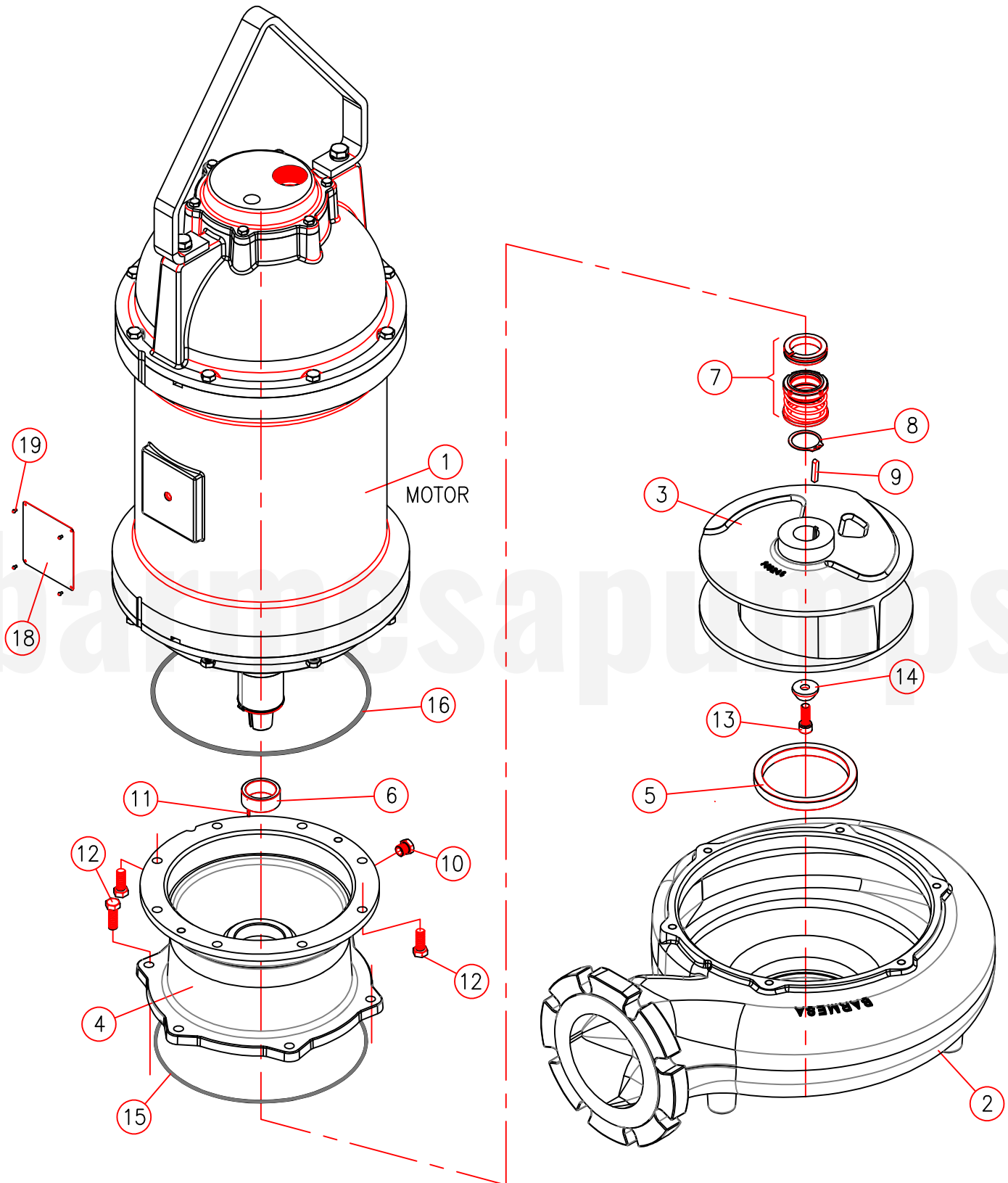

For repair part please supply: model number and serial as shown on name plate, and part description and part number as shown on parts list.

## ► 6SWH frame 320

Item	Part Number	Description	Qty.	Material
1	40043019	Motor Frame 320, 50 hp - 1750 rpm	1	N/A
	40043021	Motor Frame 320, 60 hp - 1750 rpm		
	40043023	Motor Frame 320, 75 hp - 1750 rpm		
	40040382	Motor Frame 320, 25 hp - 1150 rpm		
	40043036	Motor Frame 320, 30 hp - 1150 rpm		
	40043038	Motor Frame 320, 40 hp - 1150 rpm		
2	03090108	Volute	1	Cast Iron, Class 30
3	03140246	Impeller 14.57"Ø, 40 hp, 1150 rpm	1	Ductile Iron, 65-45-12
	03140246B	Impeller 14.14"Ø, 30 hp, 1150 rpm		
	03140246D	Impeller 13.78"Ø, 25 hp, 1750 rpm		
	03140246E	Impeller 13.19"Ø, 75 hp, 1750 rpm		
	03140246F	Impeller 12.80"Ø, 60 hp, 1750 rpm		
	03140246H	Impeller 12.01"Ø, 50 hp, 1750 rpm		
4	03180039	Seal Plate	1	Cast Iron, Class 30
5	30400377	Wear Ring Volute 6SWH	1	Bronze C954
6	30400624K	Bearing Sleeve 320	1	Bronze SAE 40
7	31030139Q	Mechanical Seal Outer 2.625"Ø Type 21, Seal with O-Ring slotted	1	Sic / Sic / Buna / SS
8	31010015K	Retaining Ring # 5100-262 SS	1	420 SS
9	30400639	Key ¼" x ¼" x 1½" SS	1	304 SS
10	93010131	Hex Head Plug 3/8" SS # 22932	1	304 SS
11	91010184C	Roll Pin 1/8"Ø x ½" SS	1	420 SS
12	91010351	Screw Hex. Head ½" x 1½" SS	14	18-8 SS
13	91010334B	Socket Head Screw ½"-20UNF x 1¼" lg.	1	304 SS
14	30400413	Impeller Washer SS	1	304 SS
15	92010064G	O-Ring # 280, Volute	1	Buna N
16	92010064F	O-Ring # 279, Seal Plate	1	Buna N
17	31010031	Motor Oil (Seal's Plate Cavity)	7 lts.	
18	94010063C	Nameplate	1	304 SS
19	91010192	Rivet SS # 001628	4	Stainless Steel

For repair part please supply: model number and serial as shown on name plate, and part description and part number as shown on parts list.

► 6SWH frame 320

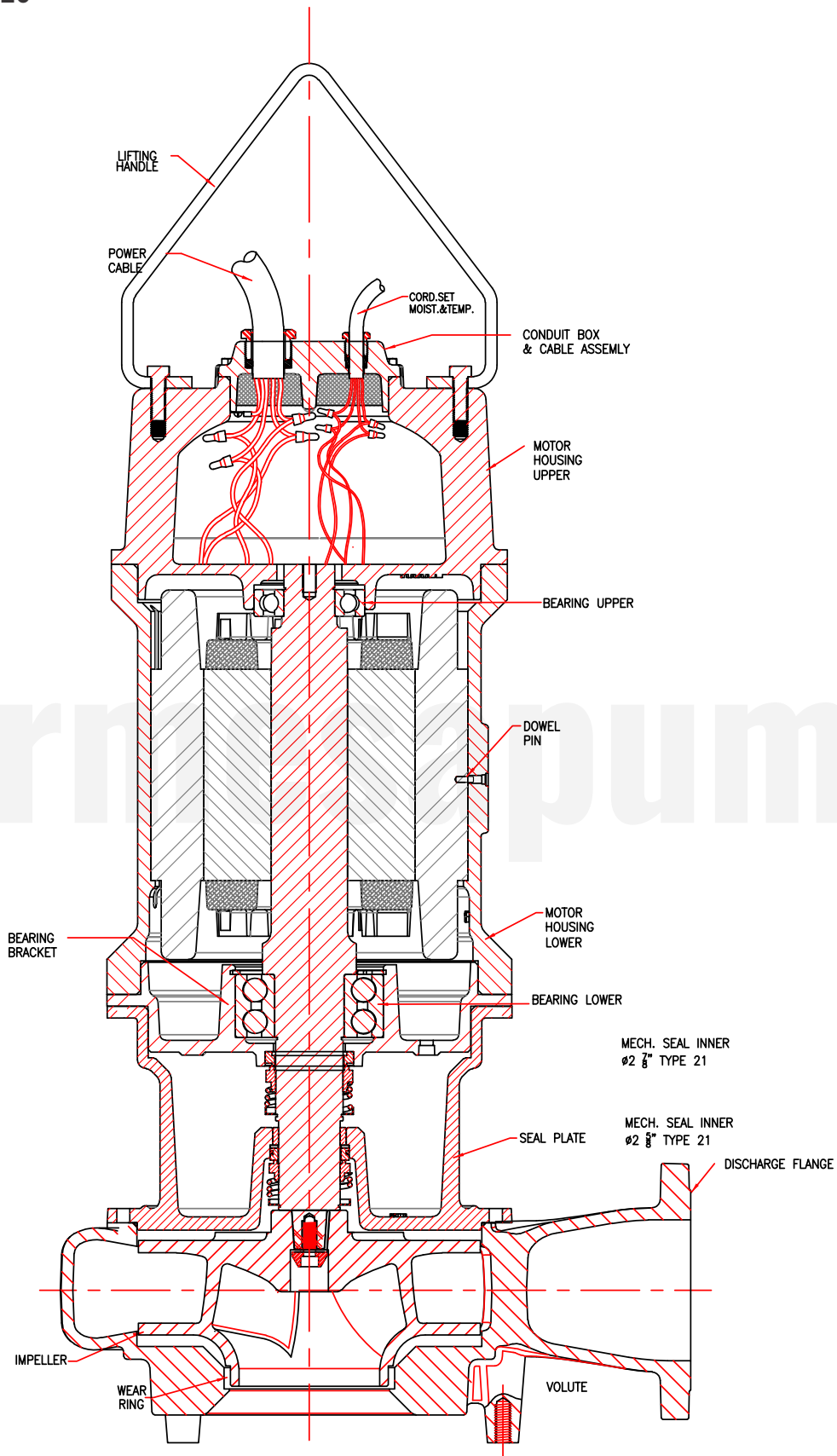

For repair part please supply: model number and serial as shown on name plate, and part description and part number as shown on parts list.



► 8SWL frame 250

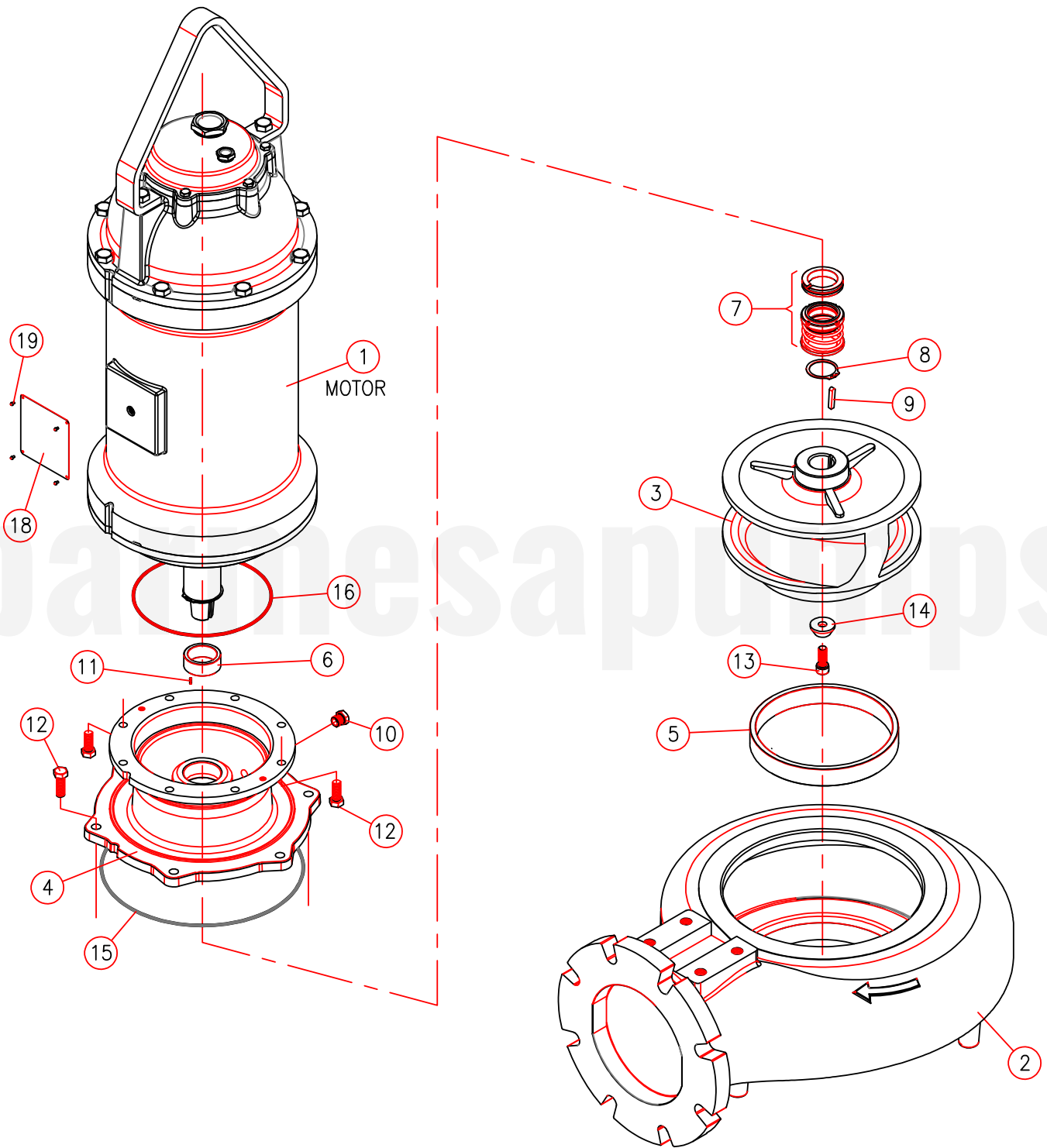

For repair part please supply: model number and serial as shown on name plate, and part description and part number as shown on parts list.

## ► 8SWL frame 250

Item	Part Number	Description	Qty.	Material
1	40043013	Motor Frame 250, 20 hp - 1750 rpm	1	N/A
	40043013	Motor Frame 250, 25 hp - 1750 rpm		
	40043015	Motor Frame 250, 30 hp - 1750 rpm		
	40043017	Motor Frame 250, 40 hp - 1750 rpm		
	40043030	Motor Frame 250, 7.5 hp - 1150 rpm		
	40043030	Motor Frame 250, 10 hp - 1150 rpm		
	40043032	Motor Frame 250, 15 hp - 1150 rpm		
	40043032	Motor Frame 250, 20 hp - 1150 rpm		
2	03090111	Volute	1	Cast Iron, Class 30
3	03140248C	Impeller 11.30"Ø, 20 hp, 1150 rpm	1	Ductil Iron, 65-45-12
	03140248E	Impeller 10.83"Ø, 15 hp, 1150 rpm		
	03140248G	Impeller 10.43"Ø, 40 hp, 1750 rpm		
	03140248H	Impeller 9.70"Ø, 10 hp, 1150 rpm		
	03140248I	Impeller 9.45"Ø, 30 hp, 1750 rpm		
	03140248J	Impeller 9.10"Ø, 7.5 hp, 1150 rpm		
	03140248K	Impeller 9.06"Ø, 25 hp, 1750 rpm		
4	03180037	Seal Plate	1	Cast Iron, Class 30
5	30400378	Wear Ring Volute 8SWL	1	Bronze C954
6	30400624H	Bearing Sleeve	1	Bronze SAE 40
7	31030139K	Mechanical Seal Outer 2.250"Ø Type 21, Seal with O-Ring slotted	1	Sic / Sic / Buna / SS
8	31010010	Retaining Ring # 5100-225 SS	1	420 SS
9	30400639	Key ¼" x ¼" x 1½" SS	1	304 SS
10	93010131	Hex Head Plug 3/8" SS # 22932	1	304 SS
11	91010184C	Roll Pin 1/8"Ø x ½" SS	1	420 SS
12	91010351	Screw Hex. Head ½" x 1½" SS	14	18-8 SS
13	91010334B	Socket Head Screw ½"-20UNF x 1¼" lg.	1	304 SS
14	30400413	Impeller Washer SS	1	304 SS
15	92010064E	O-Ring # 278, Volute	1	Buna N
16	92010089	O-Ring # 275, Seal Plate	1	Buna N
17	31010031	Motor Oil (Seal's Plate Cavity)	5.5 lt.	
18	94010074	Nameplate	1	304 SS
19	91010192	Rivet SS # 001628	4	Stainless Steel

For repair part please supply: model number and serial as shown on name plate, and part description and part number as shown on parts list.

## ► 8SWL frame 250

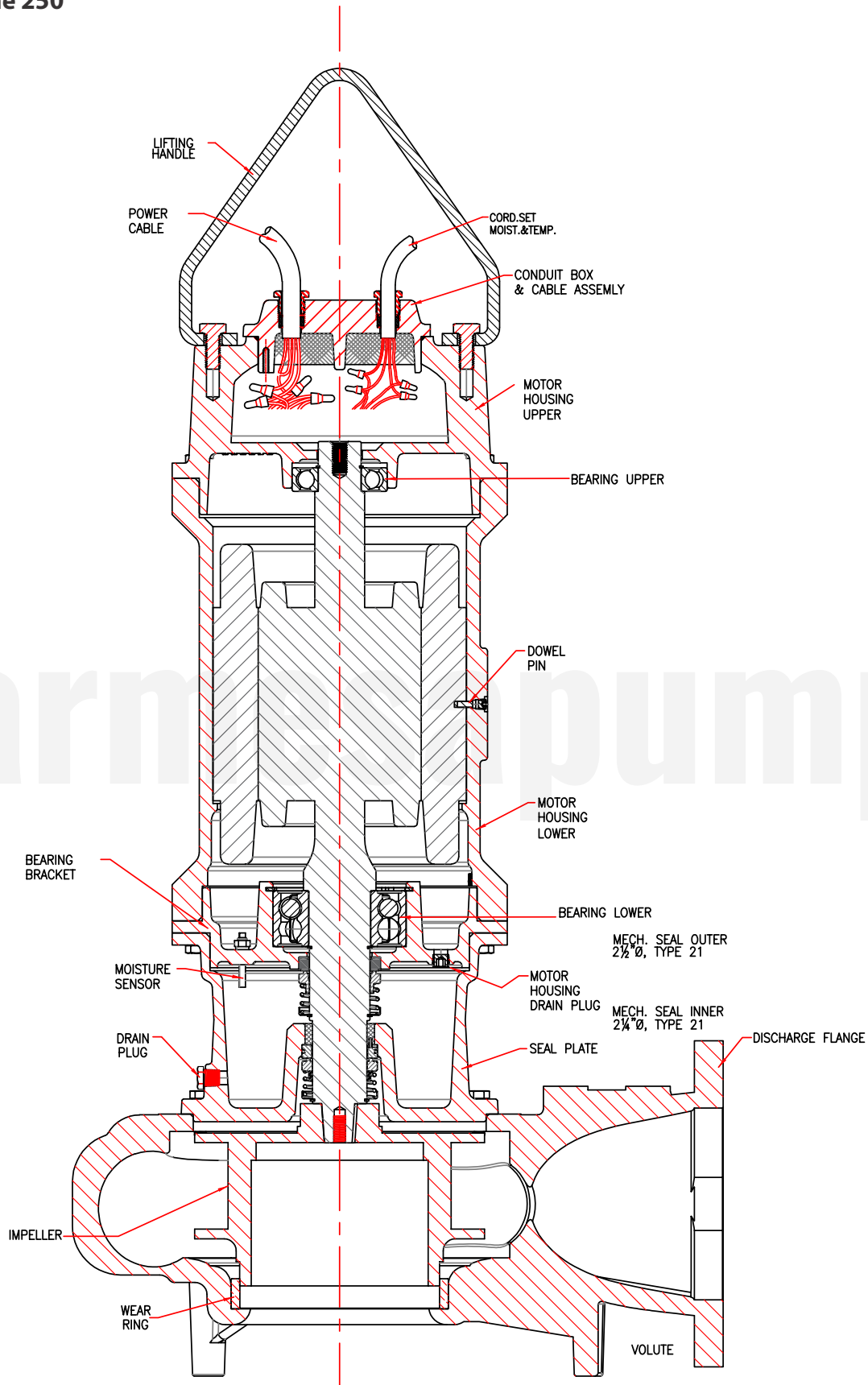

For repair part please supply: model number and serial as shown on name plate, and part description and part number as shown on parts list.



**Risk of electric shock. Always disconnect the pump from the power source before handling inspections or repairs.**

Symptom	Possible Cause(s)	Corrective Action
Pump will not run	<ol style="list-style-type: none"> <li>1. Poor electrical connection, blown fuse, tripped breaker or other interruption of power; improper power supply</li> <li>2. Motor or switch inoperative (go to manual operation)                             <ol style="list-style-type: none"> <li>2a. Float movement restricted</li> <li>2b. Switch will not activate pump or is defective</li> <li>2c. Defective motor</li> </ol> </li> <li>3. Insufficient liquid level</li> </ol>	<ol style="list-style-type: none"> <li>1. Check all electrical connections for security. Have electrician measure current in motor leads, if current is within <math>\pm 20\%</math> of locked rotor Amps, impeller is probably locked. If current is 0, overload may be tripped. Remove power, allow pump to cool, then re-check current.</li> <li>2a. Reposition pump or clean basin as required to provide adequate clearance for float</li> <li>2b. Disconnect level control. Set ohmmeter for a low range, such as 100 ohms full scale and connect to level control leads. Actuate level control manually and check to see that ohmmeter shows zero ohms for closed switch and full scale for open switch. (Float Switch)</li> <li>2c. Check winding insulation (Megger Test) and winding resistance. If check is outside of range, dry and re-check. If still defective, replace per service instructions.</li> <li>3. Make sure liquid level is above the pump</li> <li>4. Re-check all sizing calculations to determine proper pump size.</li> <li>5. Check discharge line for restrictions, including ice if line passes through or into cold areas.</li> <li>6. Remove and examine check valve for proper installation and freedom of operation</li> <li>7. Open valve</li> <li>8. Check impeller for freedom of operation, security and condition. Clean impeller cavity and inlet of any obstruction</li> <li>9. Loosen union slightly to allow trapped air to escape. Verify that turn-off level of switch is set so that the suction is always flooded. Clean vent hole</li> <li>10. Check rotation. If power supply is three phase, reverse any two of three power supply leads to ensure proper impeller rotation</li> <li>11. Repair fixtures as required to eliminate leakage</li> <li>12. Check pump temperature limits and fluid temperature</li> <li>13. Replace portion of discharge pipe with flexible connector or tighten existing piping.</li> <li>14. Turn to automatic position</li> <li>15. Check for leaks around basin inlet and outlets</li> </ol>
Pump will not turn off	<ol style="list-style-type: none"> <li>2a. Float movement restricted</li> <li>2b. Switch will not activate pump or is defective</li> <li>4. Excessive inflow or pump not properly sized for application</li> <li>9. Pump may be air locked causing pump not to flow</li> <li>14. H-O-A switch on panel is in "HAND" position</li> </ol>	
Pump hums but doesn't run	<ol style="list-style-type: none"> <li>1. Incorrect low voltage</li> <li>8. Impeller jammed or loose on shaft, or inlet plugged</li> </ol>	
Pump delivers insufficient capacity	<ol style="list-style-type: none"> <li>1. Incorrect low voltage</li> <li>4. Excessive inflow or pump not properly sized for application</li> <li>5. Discharge restricted</li> <li>6. Check valve partially closed or installed backwards</li> <li>7. Shut-off valve closed</li> <li>8. Impeller jammed or loose on shaft, or inlet plugged</li> <li>9. Pump may be air locked causing pump not to flow</li> <li>10. Piping fixtures leaking or discharge before the nozzle</li> </ol>	
Pump cycles too frequently or runs periodically when fixtures are not in use	<ol style="list-style-type: none"> <li>6. Check valve partially closed or installed backwards</li> <li>11. Fixtures are leaking</li> <li>15. Ground water entering basin</li> </ol>	
Pump shuts off and turns on independent of switch, (trips thermal overload protector). <b>CAUTION!</b> Pump may start unexpectedly. Disconnect power supply.	<ol style="list-style-type: none"> <li>1. Incorrect low voltage</li> <li>4. Excessive inflow or pump not properly sized for application</li> <li>8. Impeller jammed or loose on shaft, or inlet plugged</li> <li>12. Excessive water temperature (internal protection only)</li> </ol>	
Pump operates noisily or vibrates excessively	<ol style="list-style-type: none"> <li>2c. Worn bearings, motor shaft bent</li> <li>5. Debris in impeller cavity or broken impeller</li> <li>10. Pump running backwards</li> <li>13. Piping attachments to building structure too loose or rigid</li> </ol>	

**NOTE:** Barmesa Pumps assumes no responsibility for damage or injury due to disassembly in the field. Disassembly of the pumps or supplied accessories other than at Barmesa Pumps or its authorized service centers, automatically voids warranty.

# BARMESA PUMPS FACTORY WARRANTY

Barmesa Pumps warrants that products of our manufacture will be free of defects in material and workmanship under normal use and service for 18 months from date of manufacture or 12 months from installation date whichever occurs first. This warranty gives you specific legal rights, which vary from state to state.

This warranty is a limited warranty, and no warranty related claims of any nature whatsoever shall be made against Barmesa Pumps, until the ultimate consumer or his/her successor notifies us in writing of the defect and delivers the product and/or defective part(s) freight prepaid to our factory or nearest authorized service station as instructed by Barmesa Pumps. THERE SHALL BE NO FURTHER LIABILITY, WHETHER BASED ON WARRANTY, NEGLIGENCE OR OTHERWISE. PRODUCT SHALL BE EITHER REPLACED OR REPAIRED AT THE ELECTION OF BARMESA PUMPS. Guarantees relating to performance specifications provided in addition to the foregoing material and workmanship warranties on a product manufactured by Barmesa Pumps, if any, are subject to possible factory testing. Any additional guarantees, in the nature of certified performance specifications or time frame must be in writing and such writing must be signed by our authorized factory manager at time of order placement and/or at time of quotation. Due to inaccuracies in field testing and should a conflict arises between the results of field testing conducted by or for the user, Barmesa Pumps reserves the right to have the product returned to our factory for additional testing.

This warranty shall not apply when damage is caused by (1) improper installation, (2) improper voltage, (3) lightning, (4) excessive sand or other abrasive material, (5) corrosion build-up due to excessive chemical content or (6) uncontrollable acts of god. Any modification of the original equipment will also void the warranty. We will not be responsible for loss, damage or labor cost due to interruption of service caused by defective pumps, parts or systems. Barmesa Pumps will not accept charges incurred by others without our prior written approval.

This warranty is void if our inspection reveals the product was used in a manner inconsistent with normal industry practice and/or our specific recommendations. The purchaser is responsible for communication of all necessary information regarding the application and use of the product. UNDER NO CIRCUMSTANCES WILL WE BE RESPONSIBLE FOR ANY OTHER DIRECT OR CONSEQUENTIAL DAMAGES, INCLUDING BUT NOT LIMITED TO TRAVEL EXPENSES, CONTRACTOR FEES, UNAUTHORIZED REPAIR SHOP EXPENSES, LOST PROFITS, LOST INCOME, LABOR CHARGES, DELAYS IN PRODUCTION, IDLE PRODUCTION, WHICH DAMAGES ARE CAUSED BY ANY DEFECTS IN MATERIAL AND/OR WORKMANSHIP AND/OR DAMAGE OR DELAYS IN SHIPMENT. THIS WARRANTY IS EXPRESSLY IN LIEU OF ANY OTHER EXPRESS OR IMPLIED WARRANTY. No rights extended under this warranty shall be assigned to any other person, whether by operation of law or otherwise, without our prior written approval.

## IMPORTANT!

If you have a claim under the provision of the warranty, contact Barmesa Pumps or your authorized Barmesa Pumps Distributor:  
[warranty@barmesapumps.com](mailto:warranty@barmesapumps.com)  
[www.barmesapumps.com/US](http://www.barmesapumps.com/US)

