

Panel Wiring Diagram Model S2 IR1

Simplex Operation

High Level Alarm: This float activates the alarm light and audible alarm when lifted. The audible alarm may be silenced by pressing the illuminated PUSH TO SILENCE button on the front of the control panel. The alarm light will remain on until the float is lowered.

Pump On: This float turns on the pump when lifted. The pump will continue to run until the pump off float is lowered.

Pump Off: This float shuts off the pump when lowered.

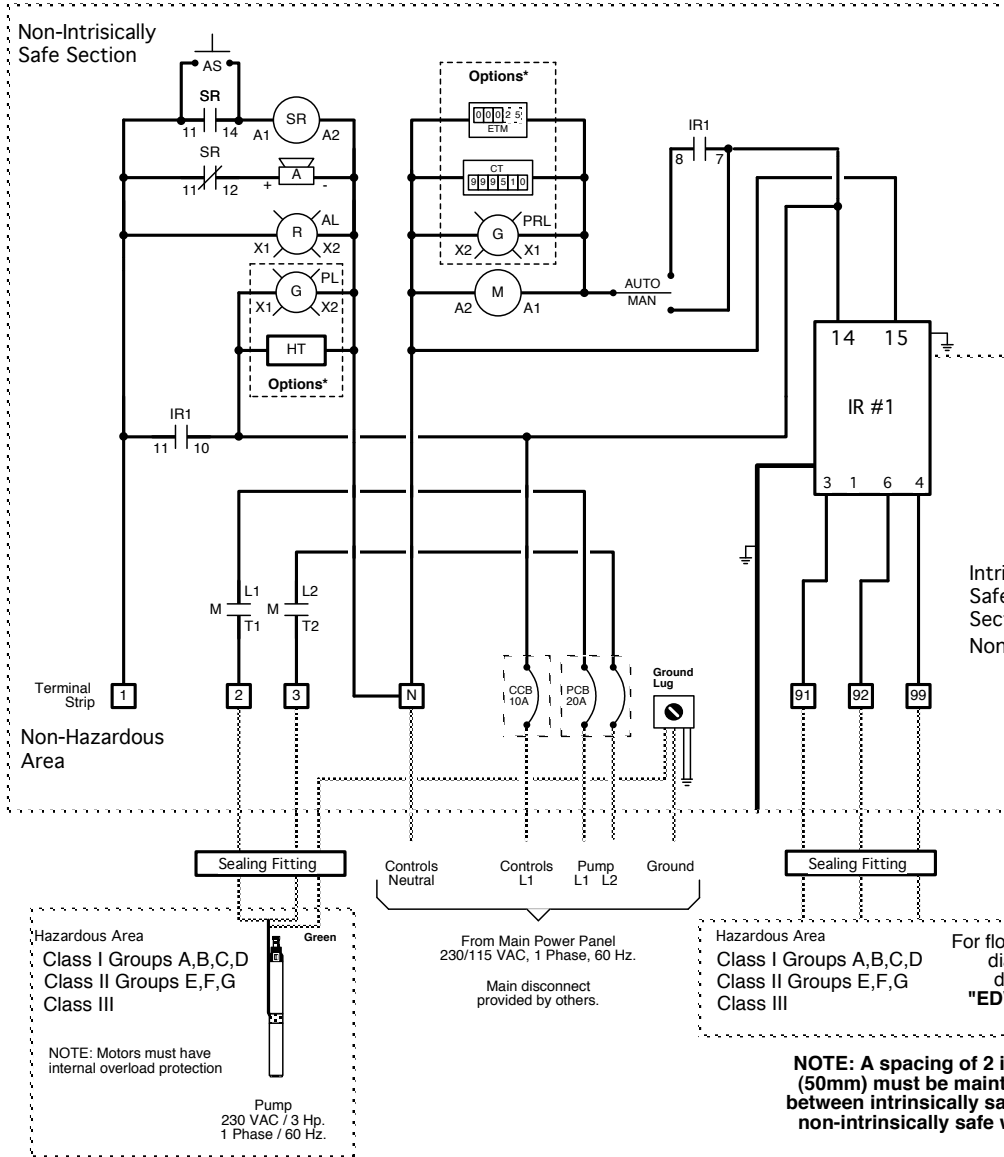

Key

- = Factory Wire
 - = Field Wire
 - - - = Alternate Field Wire
 - A = Audio Alarm, 115 VAC
 - AL = Alarm Light
 - AS = Audio Silence Switch
 - CCB = Controls Circuit Breaker
 - IR = Intrinsically Safe Relay
 - M = Motor Contactor
 - PCB = Pump Circuit Breaker
 - SR = Silence Control Relay
 - TL = Terminal Link
- *Options**
- CT = Cycle Counter
 - ETM = Elapsed Time Meter
 - HT = Heater
 - PL = Power Light
 - PRL = Pump Run Light

Remote Alarm Connections

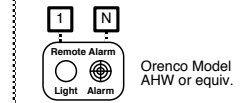

Note: 115VAC signal is present during alarm conditions.

Power Wiring Options

