

Panel Wiring Diagram Model S2 IR1 PT

Simplex Operation

High Level Alarm: This float activates the alarm light and audible alarm when lifted. The audible alarm may be silenced by pressing the illuminated PUSH TO SILENCE button on the front of the control panel. The alarm light will remain on until the float is lowered.

Timer On & Off: This float turns off the programmable timer when lowered. When this float is lifted the timer will be restarted. Note: The timer will start with its off cycle.

Programmable Timer: The timer turns the pump on and off in a pre-set cycle. Note: The timer will start with its off cycle.

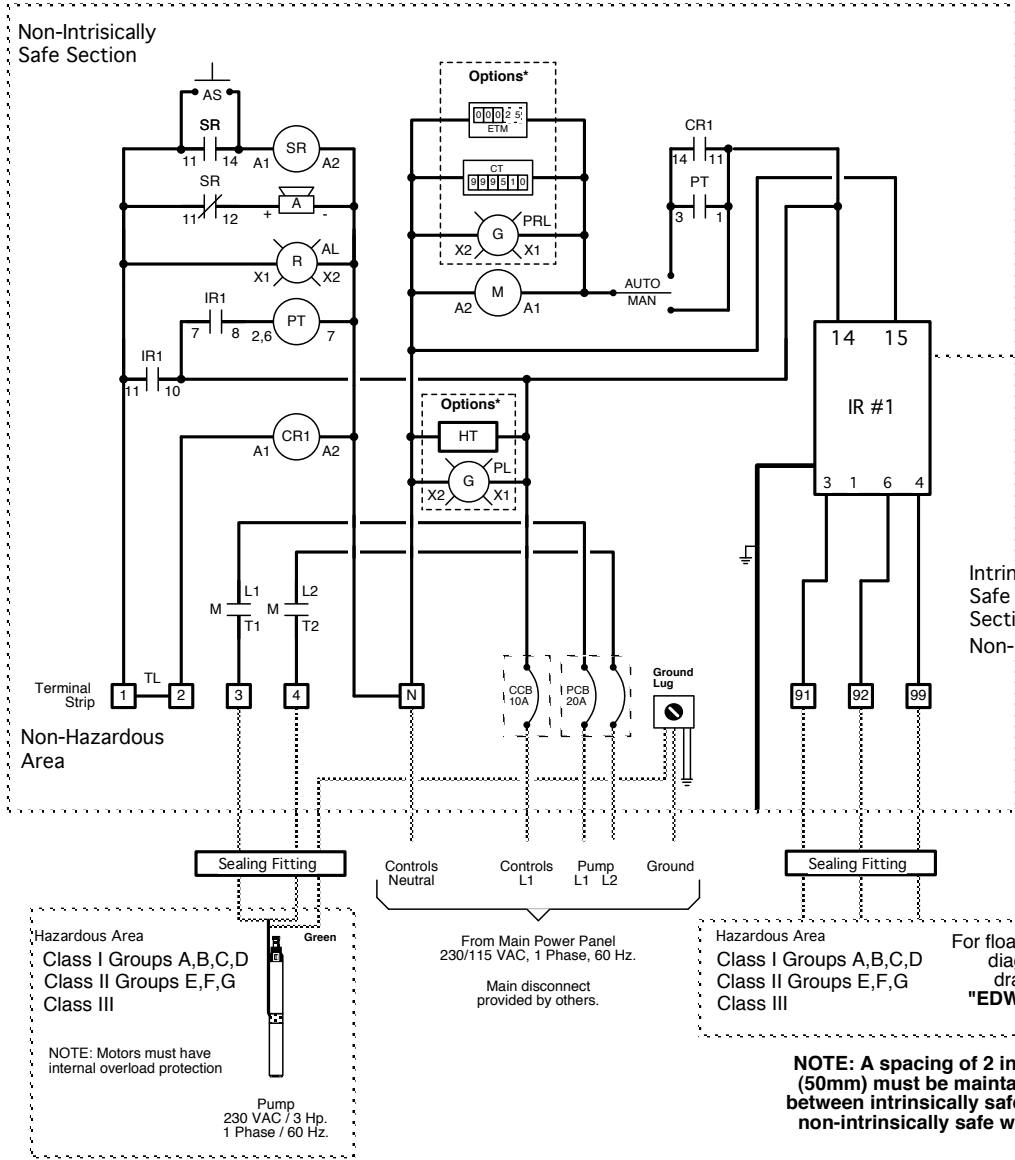

Key

- = Factory Wire
 - - - = Field Wire
 - A = Alternate Field Wire
 - AL = Alarm Light, 115 VAC
 - AS = Audio Alarm, 115 VAC
 - AS = Audio Silence Switch
 - CCB = Controls Circuit Breaker
 - CR1 = Override Relay
 - IR = Intrinsically Safe Relay
 - M = Motor Contactor
 - PCB = Pump Circuit Breaker
 - SR = Silence Control Relay
 - TL = Terminal Link
- *Options**
- CT = Cycle Counter
 - ETM = Elapsed Time Meter
 - HT = Heater
 - PL = Power Light
 - PRL = Pump Run Light

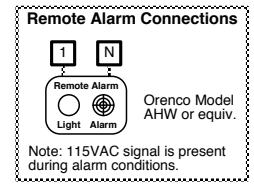

Power Wiring Options

