

# SINK PUMP SYSTEM

## ED33 SERIES

The ED33 Series Sink Pump System is a time and money saving solution and suited for many jobs. Fast, easy installation with no need to dig a sump pit. This pre-packaged sink pump system includes a heavy duty cast iron pump and a corrosion resistant poly basin years making it perfect for extended service.

### APPLICATIONS

Laundry trays, wet bars, beautician or utility sinks, dehumidifiers, and air-conditioning units.

### FEATURES

- ◆ **On Ground Installation:** Without the requirement of digging a sump pit, the system quickly sets up on any solid surface.
- ◆ **Heavy Duty Basin Design:** Corrosion resistant, heavy duty poly basin with curved edge design for increased strength and longer service life.
- ◆ **High Flow Discharge:** 1-1/2" NPT discharge.
- ◆ **Operation:** Automatic vertical switch with piggy-back plug for manual operation.
- ◆ **Years of Service:** Includes the dependable and tested MDC series pump.
- ◆ **Industry Proven Pump Design:**
  - Oil-cooled motor for continuous lubrication and heat dissipation.
  - Long life carbon/ceramic seal protects motor against water leakage.
  - Internal heat sensor provides over-load protection and automatic reset.
  - Shaded pole motor eliminates failure prone internal relays and switches.



### SPECIFICATIONS

- ◆ **Capacities:** 53 GPM (182 LPM)
- ◆ **Shut-Off Head:** 24' (7.3 m)
- ◆ **Operation:** On = 6-1/2" (165 mm) Off = 2" (50 mm)
- ◆ **Solids Handling:** 1/2 (12.7 mm)
- ◆ **Liquids Handling:** Drainage effluent
- ◆ **Intermittent Liquid Temp.:** Up to 130°F (54°C)
- ◆ **Motor/Electrical Data:** 1/3 HP, 115V, 9.8 FLA, 1Ø, 60Hz
- ◆ **Acceptable pH Range:** 5-9
- ◆ **Shaft Seal:** Carbon and ceramic
- ◆ **Housing:** Cast iron
- ◆ **Power Cord:** 10' (3 m), grounded SJTW, SJTW-A
- ◆ **Discharge NPT:** 1-1/2"

### ORDERING INFORMATION

CATALOG NUMBER	HP	VOLTS	PHASE	AMPS	DISCHARGE NPT	SWITCH TYPE	CORD LENGTH	APPROX. WT. LBS.
ED33V1	1/3	115	1	9.8	1-1/2"	Vertical Automatic	10'	34

# SINK PUMP SYSTEM ED33 SERIES

## DIMENSIONS

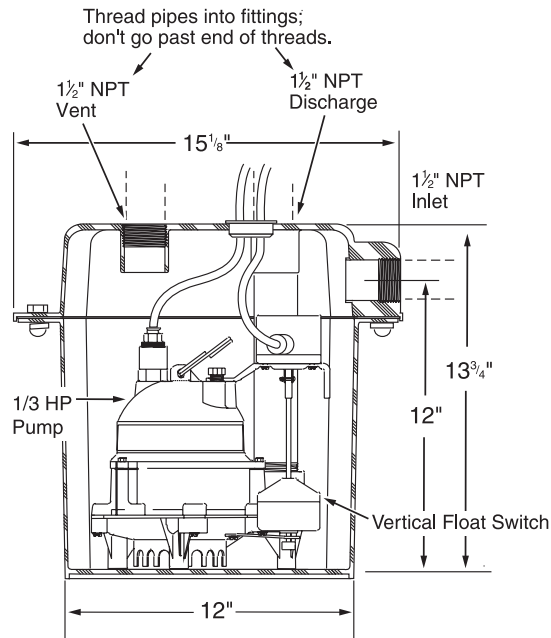

## PUMP PERFORMANCE

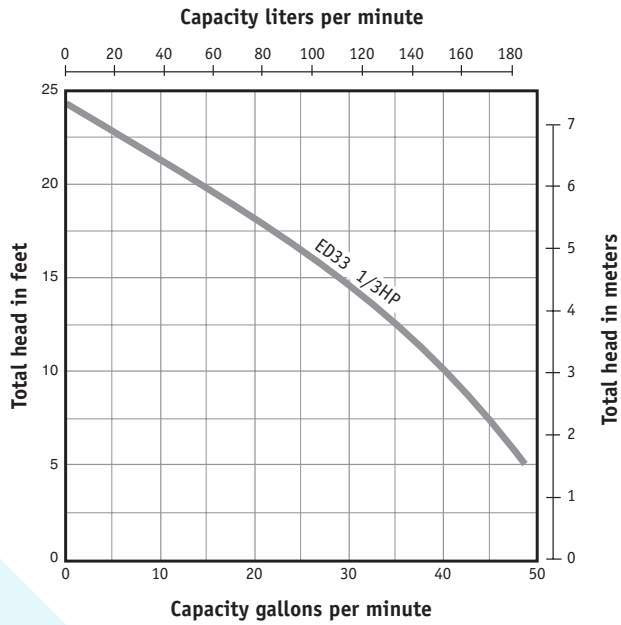

293 Wright St  
Delavan, WI 53115  
Ph: 888.987.8677  
Fx: 800.426.9446

490 Pinebush Rd, Unit 4  
Cambridge, Ontario N1T 0A5, Canada  
Ph: 800.363.7867  
Fx: 888.606.5484

pentair.com

All indicated Pentair trademarks and logos are property of Pentair. Third party registered and unregistered trademarks and logos are the property of their respective owners. Because we are continuously improving our products and services, Pentair reserves the right to change specifications without prior notice. Pentair is an equal opportunity employer.

©2023 Pentair. All Rights Reserved.

M9018SSE (08-01-23)