

# 111-INSIDER-P / 231-INSIDER-P

## Single-Phase Pump Monitor



### Wiring Diagrams

See next page.

### Accessories



#### Informer

A hand-held diagnostic tool that uses an infrared receiver to access information which can be helpful for troubleshooting the system. Includes the Informer IR Kit-12



#### Informer IR Kit-12

12" infrared adapter cable attaches to the face of the unit to provide remote diagnostics without opening the panel. Included with the Informer

### Ordering Information

MODEL	VOLTAGE	DESCRIPTION
111-Insider-P	115VAC	1/3 - 1/2 hp, includes IR Kit-12
231-Insider-P	230VAC	1/3 - 1 hp, includes IR Kit-12

### Description

The Littelfuse 111-Insider-P single-phase products fit inside 1/3 and 1/2, 115V control boxes and the 231-Insider-P fits inside 1/3 1/2, 3/4, and 1 hp, 230V control boxes. Both models are designed to protect single-phase pumps from dry-well, dead-head, jammed impeller, rapid-cycle, overvoltage, and undervoltage conditions.

A calibration adjustment allows the Insider to be calibrated to your specific pumping applications, thereby reducing the possibility of false or nuisance tripping. A unique microcontroller-based voltage and current-sensing circuit constantly monitors the incoming power for fluctuations, overcurrent, and undercurrent. When an abnormality, such as loss of suction is detected, the product deactivates its output relay and directly disconnects the pump motor. The unit then begins its user-selectable restart delay (dry-well recovery) timer. When the timer counts to zero or power is removed and reapplied, the unit reactivates its output relay and turns the pump back on. By leaving the restart delay knob in the reset position, the unit will operate in manual reset mode.

The Insider communicates with a hand-held diagnostics tool called the Informer (sold separately). The Informer displays parameters including calibration points, trip points, run time and last faults. An IR Kit-12 (12" fiber optic kit) is included with each Insider, allowing the Informer to access these parameters even when the Insider is enclosed in a control box. This is valuable for troubleshooting the pump while it is running.

NOTE: The 111/231-Insider-P models have a sensitivity adjustment for the dry-well trip point. After calibration is done, you can adjust the sensitivity for the dry-well/dead-head trip point from 70-90% of the full load. This makes the unit even more adaptable to varying pumping applications. If you have a very low producing well, you increase the sensitivity closer to the 90% mark, or if you have a very heavy producing well, you would decrease the sensitivity around the 70% mark.

### Features & Benefits

FEATURES	BENEFITS
<b>Proprietary microcontroller based circuitry</b>	Constant monitoring of voltage and current protects pumps from dry-well, dead-head, jammed impeller, rapid cycling, and voltage faults
<b>Onboard sensitivity adjustment</b>	Allows user to adjust the current sensitivity for the dry-well / dead-head trip point from 70% - 90% of the full load.
<b>Adjustable restart delay</b>	Allows user to select well recovery time delay after a dry-well condition occurs, or to select manual reset
<b>Built in IR communications link</b>	Used with the Informer, allows user to see stored faults, run time, and also troubleshoot the pump while it's running
<b>LED indication</b>	Provides status and diagnostics for troubleshooting

7

MOTOR & PUMP PROTECTION

# 111-INSIDER-P / 231-INSIDER-P

## Specifications

### Functional Specifications

#### Adjustments/Settings

<b>Overcurrent</b>	125% of calibration point
<b>Underload (dry-well)</b>	Adjustable (70 to 90% of calibrated run power)
<b>Overvoltage</b>	
<b>111-Insider-P</b>	132.5VAC
<b>231-Insider-P</b>	265VAC
<b>Undervoltage</b>	
<b>111-Insider-P</b>	95VAC
<b>231-Insider-P</b>	190VAC
<b>Number of restarts allowed in a 60-sec. period (rapid-cycling)</b>	4
<b>Trip Delay Times</b>	
<b>Overcurrent</b>	5 seconds
<b>Dry-well</b>	4 seconds
<b>Restart Delay Times</b>	
<b>Over/Undervoltage</b>	2 seconds
<b>All other faults</b>	Manual, 2-225 minutes

### Input Characteristics

<b>Supply Voltage</b>	
<b>111-Insider-P</b>	115VAC
<b>231-Insider-P</b>	230VAC
<b>Load Range</b>	
<b>111-Insider-P</b>	1/3 – 1/2 hp
<b>231-Insider-P</b>	1/3 – 1 hp
<b>Frequency</b>	50*/60Hz

### Output Characteristics

<b>Output Contact Rating-SPST</b>	
<b>111-Insider-P</b>	1/2hp@120VAC (17 amps max.)
<b>231-Insider-P</b>	1hp@240VAC (17 amps max.)

### General Characteristics

<b>Operating Temperature</b>	-40° to 60° C (-40° to 140° F)
<b>Maximum Input Power</b>	5 W

### Safety Marks

<b>cUR**</b>	UL508, C22.2 No. 14
<b>Weight</b>	10 oz.

### Mounting Methods

Inside a Pentek®, Franklin™, CentriPro™, Flint and Walling™, and Grundfos®\*\*\* control box

\*Note: 50Hz will increase all delay timers by 20%

\*\*The 111-Insider-P and 231-Insider-P are approved by UL for use in the Franklin™, Pentek®, and CentriPro™ type 3R control boxes when installed as described in the installation instructions. The 111-Insider-P and 231-Insider-P are not intended to provide overload protection, and should be used with thermally or impedance protected motors only.

\*\*\*Grundfos control boxes manufactured after mid 2014.

7

MOTOR & PUMP PROTECTION

## Wiring Diagrams

PENTEK® CONTROL BOX WIRING DIAGRAM

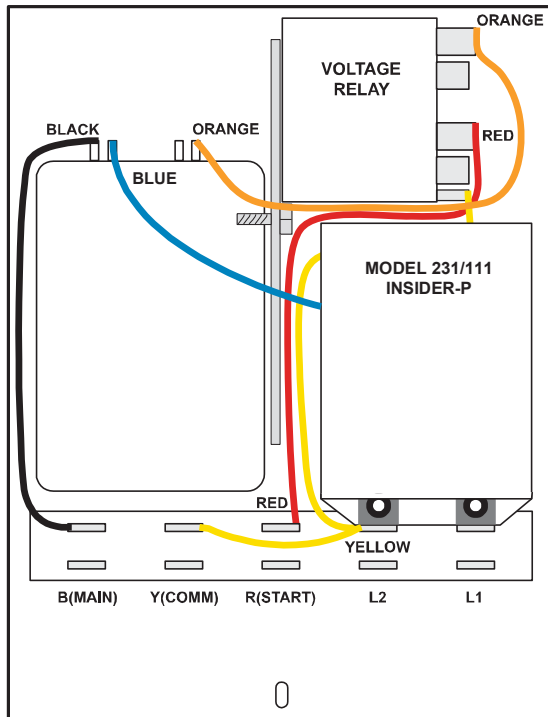

FRANKLIN™ CONTROL BOX WIRING DIAGRAM

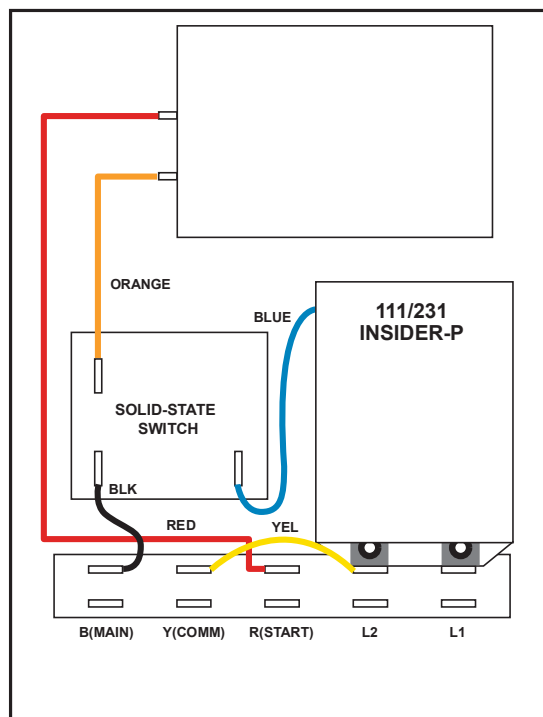

# 111-INSIDER-P / 231-INSIDER-P

CENTRIPRO™ CONTROL BOX WIRING DIAGRAM

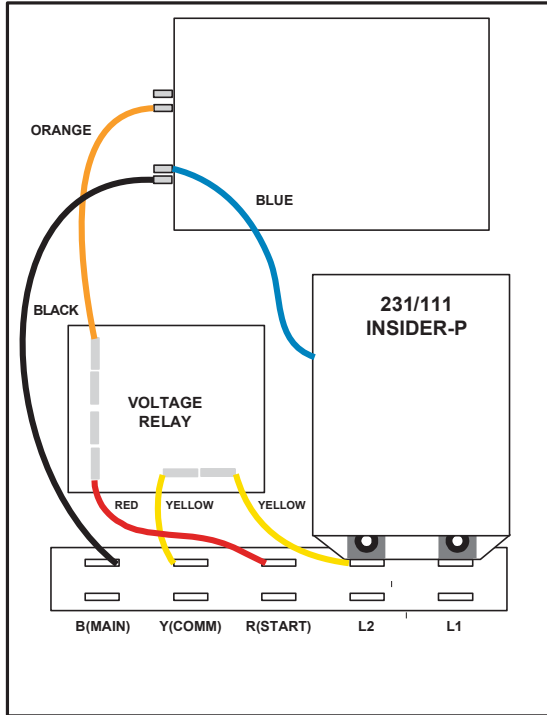

FLINT AND WALLING™ CONTROL BOX WIRING DIAGRAM

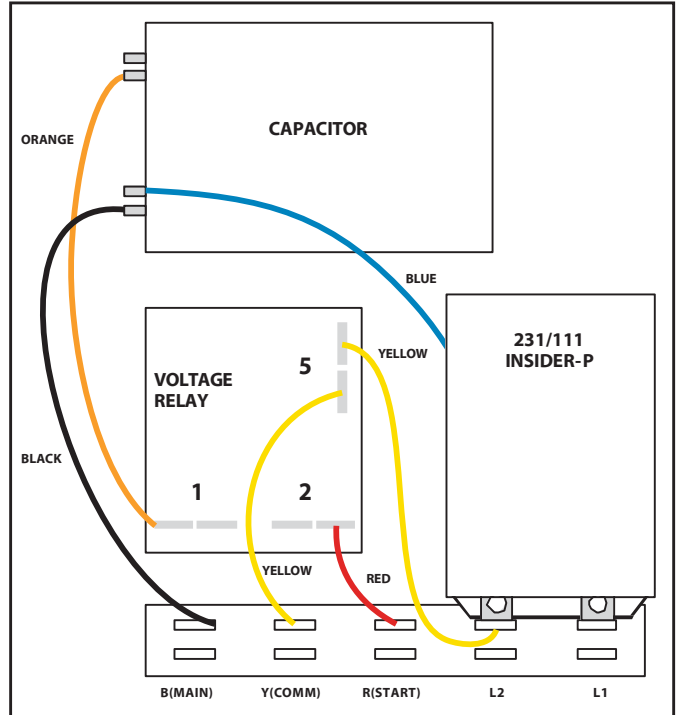

GRUNDFOS® CONTROL BOX\* WIRING DIAGRAM

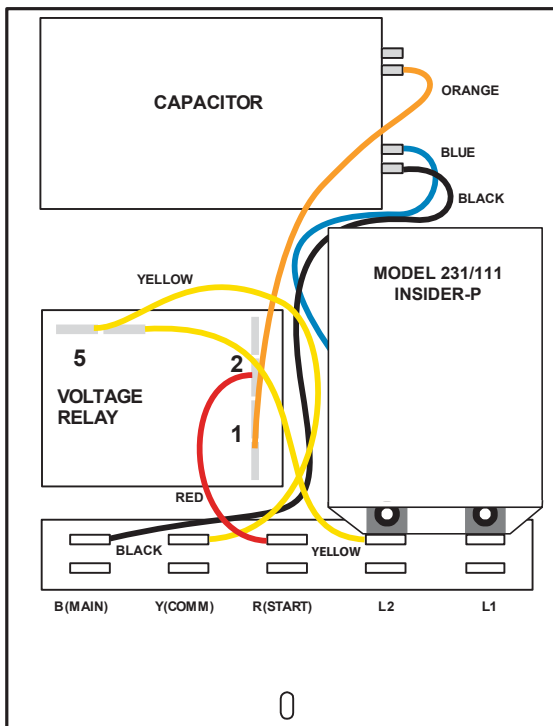

For installation instructions see the Fresh Water Pumping Catalog at [www.Littelfuse.com/PumpProtection](http://www.Littelfuse.com/PumpProtection)

\* For boxes manufactured in mid 2014 or later.  
See 232-INSIDER on next page for boxes manufactured prior to mid 2014.