



Subsurface Drip Dispersal and Reuse

Design, Installation and Maintenance Guidelines

The logo for Geoflow, Inc. is a circular emblem with a black outer ring and a light blue center. The center features a stylized, swirling pattern in shades of blue and purple. The company name and contact information are printed in black text within the circle.

Geoflow, Inc
506 Tamal Plaza
Corte Madera, CA
94925
Toll free: 800-828-3388
Tel: 415-927-6000
Fax: 415-927-0120

CONTENTS

INTRODUCTION.....	3
DIAGRAM 1: TYPICAL DRIPFIELD LAYOUT	4
SYSTEM COMPONENTS:.....	5
○ WASTEFLOW® DRIPLINE.....	5
○ CONTROLLERS.....	6
○ PUMPS, PUMP TANKS & FLOATS	6
○ FILTERS	7
○ SUPPLY MANIFOLD AND LINE	7
○ RETURN MANIFOLD AND LINE.....	7
○ PRESSURE REGULATOR	7
○ AIR VACUUM BREAKER.....	7
○ FILTER FLUSH VALVES	7
○ FIELD FLUSH VALVES.....	8
○ ZONE VALVES.....	8
○ WASTEFLOW HEADWORKS	8
DESIGN PARAMETERS:.....	8
○ SELECT AREA	8
○ WATER QUALITY	8
○ SOIL APPLICATION DESIGN.....	8
○ TABLE 1 - DRIP LOADING RATES CONSIDERING SOIL STRUCTURE.	10
○ DEPTH AND SPACING	11
○ SOIL LAYERS AND TYPES	11
○ ADDING FILL TO THE DISPERSAL FIELD	11
○ SLOPES OR HILLY SITES	12
○ MULTIPLE ZONES.....	13
○ FLUSHING DESIGN	14
○ WINTERIZATION.....	14
○ LIGHTNING PROTECTION.....	15
○ REUSE FOR IRRIGATION	15
○ WATER APPLICATION FORMULA.....	16
○ WORKSHEET 1 - DISPERSAL FIELD DESIGN FOR SINGLE ZONE SYSTEM	17
○ WORKSHEET 2 - PRESSURE LOSSES	17
SYSTEM INSTALLATION	20
○ INSTALLATION GUIDELINES.....	20
○ TABLE 2. SUBSURFACE DRIP INSTALLATION METHODS.....	23
○ WORKSHEET 3 - AS BUILT SYSTEM DESCRIPTION.....	24
SYSTEM MAINTENANCE.....	25
○ ROUTINE AND PREVENTATIVE MAINTENANCE	25
○ SITE INSPECTION LIST:	27
○ TROUBLE SHOOTING GUIDE:	28
KEY COMPONENTS.....	31
PRODUCT SHEETS – LIMITED. Complete list available at www.geoflow.com	33



INTRODUCTION

Geoflow's WASTEFLOW®¹ drip disperses effluent below ground surface through ½" pressurized pipes. It is designed using the grid concept with supply and flush manifolds at each end of the dripline creating a closed loop system. The grid design provides a complete subsurface wetted area.

The objective with effluent dispersal is usually to disperse the effluent using the minimum area as quickly and safely as possible at an approximately uniform rate throughout the year. If the main purpose of the Geoflow system is to irrigate, then please use the standard irrigation manual for landscape available from Geoflow, Inc.

Subsurface drip is a highly efficient method to dispose of effluent. Small, precise amounts of water are uniformly applied under the soil surface from multiple points.

The main advantages of Geoflow's subsurface drip system for effluent dispersal are:

- Human and animal contact with effluent is minimized, reducing health risks.
- Correctly designed systems will not cause puddling or runoff.
- It can be used under difficult circumstances of high water tables, tight soils, rocky terrain, steep slopes, around existing buildings, trees or other vegetation, and on windy sites.
- Disposal of water is maximized by means of evapotranspiration.
- The system requires no gravel. It is easy to install directly into indigenous soils and the natural landscape can be maintained.
- Minimizes deep percolation.
- Consumption of nitrates by the plant material is increased.
- Invisible and vandal proof installations.
- Ten-year warranty for root intrusion, workmanship and materials. Systems are durable with a long expected life of approximately 30 years.
- Non intrusive. It allows use of the space while operating.
- Easily automated.
- Effluent can be re-used for irrigation.

NOTES

- These guidelines are geared towards single family homes with secondary treated effluent. When using primary treated effluent, Geoflow recommends automating all the self flushing valves, and increasing the number of emission points in the dispersal field. For more information on septic tank dispersal, please check our website at www.geoflow.com or telephone Geoflow at 800-828-3388.
- Systems with periodic use need special attention not covered in this guideline.
- Please follow your State and County Regulations for onsite wastewater dispersal. These guidelines are intended to be a guide to users of the Geoflow drip system and should be used only as a supplement to your local regulations.
- Occasionally, in forested area, the dripline is placed on the surface and covered with mulch.

¹ WASTEFLOW® is a registered trademark of A.I.Innovations.

DIAGRAM 1: TYPICAL DRIPFIELD LAYOUT
Single Family Home

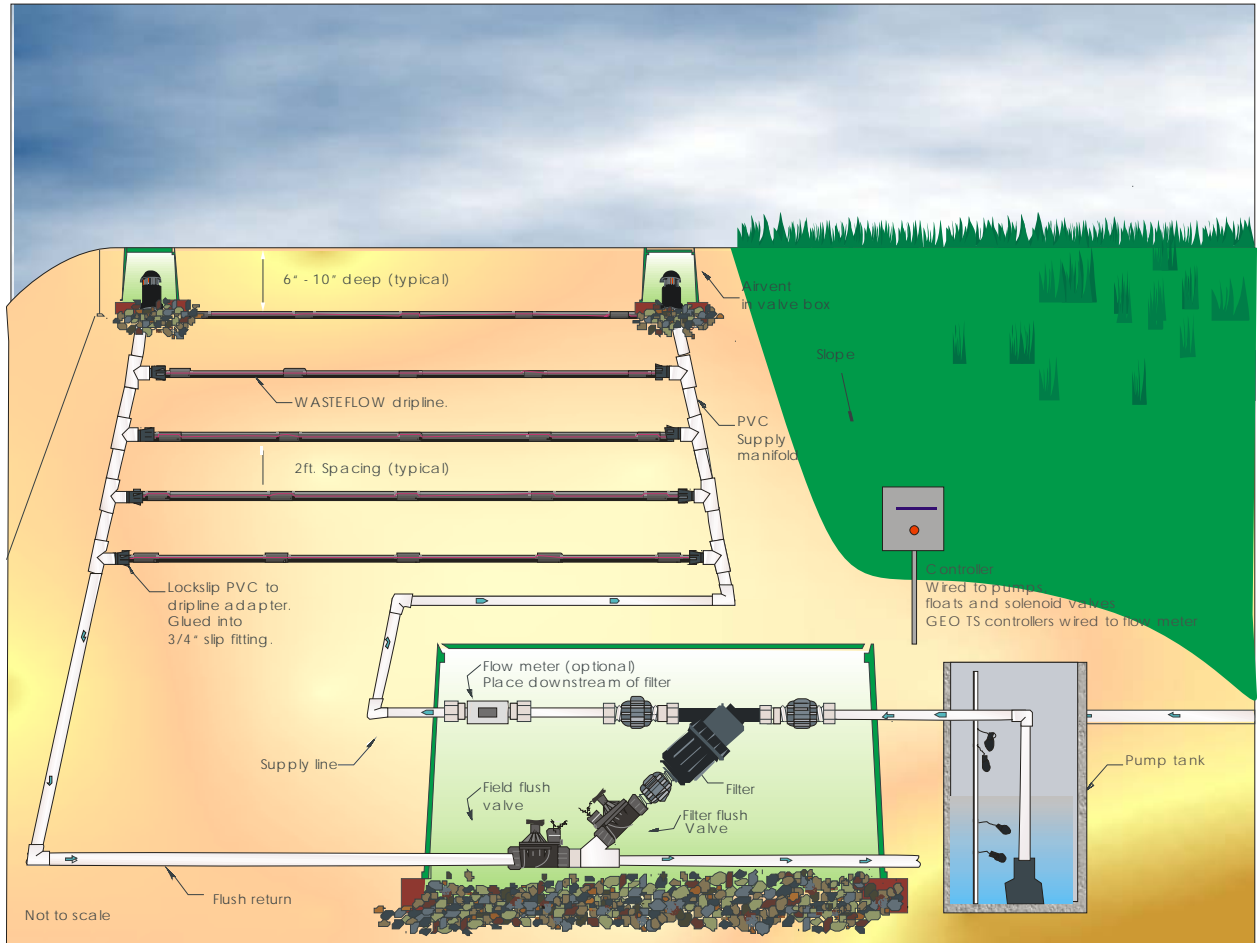

SYSTEM COMPONENTS:

See Diagram 1 on page 4.

A typical drip system installation will consist of the elements listed below:

1. WASTEFLOW® DRIPLINE

WASTEFLOW dripline carries the water into the dispersal/reuse area. The dripline is connected to the supply and return manifolds with Compression or Lockslip fittings. Typical spacing between each dripline and between drip emitters is 24" on center.

Twelve-inch spacing is used regularly for soils with very low or high permeability. Dripline is usually buried 6"-10" below ground. Standard coil length is 500-ft. Rolls of alternative lengths, diameters and dripper spacing's may be special ordered.

WASTEFLOW dripline features:

a) nano-ROOTGUARD®²

Wasteflow dripline has nano-ROOTGUARD®. The risk of root intrusion with an emitter slowly releasing nutrient rich effluent directly into the soil is well known to anyone who has observed a leaking sewer pipe. All Geoflow drip emitters are guaranteed to be protected against root intrusion with nano-ROOTGUARD. This patented process fuses the root-growth inhibitor, TREFLAN®³ into each drip emitter during manufacturing. Treflan is registered with the United States EPA for this application. The nano-ROOTGUARD technology holds Treflan for extended time inside the plastic, slowly releasing it in minute quantities to prevent root cells from dividing and growing into the barrier zone. It is chemically degradable, non-systemic, and virtually insoluble in water (0.3 ppm). With an expected life of 30 years, nano-ROOTGUARD carries a 15-year warranty against root intrusion.

b) Geoshield™⁴ protection

Geoflow's WASTEFLOW has an inner lining impregnated with an antimicrobial, Tributyl tin maleate, to inhibit adhesion of biological growth on the inside walls of the tube and on the emitters. It does not have any measurable biological effect on the effluent passing through the tube. This minimizes the velocity required to flush WASTEFLOW dripline. The velocity only needs to move out the fine particles that pass through the 130 micron filter that, if not flushed, will ultimately accumulate at the distal end of each lateral. It is not necessary to scour growth off the inside wall of WASTEFLOW tubing. Since all pumps deliver more volume given less resistance to flow, just opening the flush valve will usually achieve this degree of flushing. When a minimum flushing velocity is requested by regulators, 0.5 feet per second is used with Wasteflow dripline to get the settled particles at the bottom of the pipe back into suspension. This equates to 0.375 gpm per dripline when using standard WASTEFLOW dripline (0.55"ID)

c) Turbulent Flow Path

WASTEFLOW drip emitters are pre-inserted in the tube usually spaced 6", 12", 18", or 24" apart with 24" being the most popular. Angles in the emitter flow path are designed to cause turbulence in order to equalize flow between emitters and keep the emitters clean. Geoflow emitters boast large flow paths, which, coupled with turbulent flow, have proven over the years to be extremely reliable and dependable.



² NANOROOTGUARD is a registered trademark of A.I.Innovations

³ Treflan is a registered trademark of Dow Agro Sciences

⁴ Geoshield is a registered trademark of A.I.Innovations

d) WASTEFLOW Classic and WASTEFLOW PC Dripline

Both WASTEFLOW Classic and WASTEFLOW PC have turbulent flow path emitters with nano-ROOTGUARD and *Geoshield* protection.

The WASTEFLOW PC has the added element of a silicone rubber diaphragm that moves up and down over the emitter outlet to equalize flows regardless of pressure between 7 and 60 psi. To ensure a long life the recommended operating range is 10 to 45 psi.

For WASTEFLOW Classic, the flow rate delivered by the emitter is a function of the pressure at the emitter. The Classic dripline has the advantage of no moving parts or rubber that may degrade over time. Also, when minimum flushing velocities are required, the flows during a dosing cycle and flushing cycle are very similar with the Wasteflow Classic because when the flush valve is opened; the pressure is reduced, causing the flows from the emitters to decline. PC dripline requires significantly higher flow for flushing than dosing as the emitter flow does not go down during the flushing cycle.

We generally recommend using WASTEFLOW Classic, unless the economic advantages to using PC is substantial.

- i) WASTEFLOW PC can run longer distances than WASTEFLOW Classic.
- ii) Steep slopes. Systems should be designed for the dripline lateral to follow the contour. When this is practical, the extra cost of installing pressure regulators required for WASTEFLOW Classic would likely be less than the incremental cost of WASTEFLOW PC.
- iii) Rolling terrain. If the difference in height from trough to peak exceeds six feet then WASTEFLOW PC should be used. Vacuum relief valves must be placed at the top of each rise.

2. CONTROLLERS

Controllers are used for time dosing and time flushing of the filter and dripfields. GEO controllers include a programmable logic controller to increase flexibility and reliability in the field. They can be used on systems ranging in size from one to eight zones at the time this manual was printed. All controllers include a surge arrestor, elapsed time meter and counter. The choice as to which controller best supports your personal preference, capability and price.

3. PUMPS, PUMP TANKS & FLOATS

WASTEFLOW dripfields depend on pumps to dose effluent under pressure to the field. These must be sized according to flow and pressure requirements. Look for submersible effluent pumps from a dependable source. Geoflow does not endorse a single manufacturer, but does advocate you use a pump that is readily serviced in your area. Two (duplex) pumps may be used. These will normally alternate at each signal from the control panel and are often used on commercial or large drip systems.

Pump tanks are an important part of an onsite system design and serve to equalize flow, settle solids and even continue oxidation in some instances. All treatment systems will have occasional upsets, and an adequately sized pump tank will help increase the time between filter cleaning. Pump tanks should be sized according to your local rules and regulations. We recommend pump tanks for single family homes be at least 1.5 times daily flow. Remember a 500 gallon pump tank may not actually hold 500 gallons because of the loss of useable areal below the pump intake and above the high water cutoff level. Geoflow controllers are set-up for 4 floats with the lowest one in the tank being the *redundant off float*. The *primary timer on/off float* is second from the bottom, followed by the *secondary timer float* third from the bottom and the *high level alarm float* on the top.

4. FILTERS

Geoflow systems require 120 mesh or 130 micron filtration to keep any oversized upstream contaminants from entering the dripline. Geoflow offers a full range of drip filters, with the tried and true Vortex screen filters for small commercial and residential systems; disc filters with anti bacterial protection, and GeoVac suction cleaning filters for larger commercial and industrial systems. We recommend minimum filter size of 1.5inch.

5. SUPPLY MANIFOLD AND LINE

This carries the water from the dosing tank to the dispersal area. Rigid PVC schedule 40 is usually used. Schedule 80 is at times used to either avoid dips in the line that can collect water and freeze, or if pressure of at least 200 psi is required to pump water from the dose tank to the dripfield. To prevent water from freezing, the pipes should slope back to the pump tank, be buried below frost depth and/or be insulated. Refer to the PVC pipe sizing chart in the appendix to determine the best diameter for your application.

6. RETURN MANIFOLD AND LINE

In order to help clean the system, the ends of the drip lines are connected together into a common return line, most often made of rigid PVC. This line will help equalize pressures in the system. Flushing should be done frequently during the installation period. Periodic flushing during operation will help to keep the manifolds clean. Best option is to return flush water to the inlet of the treatment stream. If this is not possible, a two compartment pump tank with diffuser is recommended with pump in separate chamber. To prevent water from freezing, the pipes should slope back to the pump tank, be buried below frost depth and/or be insulated.

7. PRESSURE REGULATOR

Pressure regulators fix the inlet pressure at a given rate. Under normal operating conditions, pressure in the drip lines should be 10 psi to 45 psi. With WASTEFLOW Classic it helps to know exactly what the pressure is in the dripline, so system flow can be easily calculated. With all dripline it is prudent to have a pressure regulator to avoid oversized pumps from blowing out fittings.

8. AIR VACUUM BREAKER

Air vacuum breakers are installed at the high points, above dripline and below grade to keep soil from being sucked into the emitters due to back siphoning or backpressure. This is an absolute necessity with underground drip systems. They are also used for proper draining of the supply and return manifolds in sloping conditions. One is used on the high end of the supply manifold and one on the high point of the return manifold. Additional air vents may be required in undulating terrain. Freezing conditions require the air vacuum breaker be protected with insulation.

9. FILTER FLUSH VALVES

Used to flush debris from the filter cleanout port back to the pretreatment or dosing tank, this can be an electronically activated solenoid valve or a manual valve. If manual, it should be opened for a full flushing at least every six months and left cracked open slightly to flush continuously. Certain States may require automated electronic flushing. Please refer to your State codes.

10. FIELD FLUSH VALVES.

Used to flush out fine particles that have passed through the filter and accumulated on the bottom of the tube at the end of each lateral, the field flush valve can be manual (continuous) or electronic (automatic). Geoflow recommends automatic flush. Continuous flush requires the valve be left cracked open slightly during operation and must be carefully designed and operated to work without increasing the risk of treatment plant upsets (if placed upstream of treatment) or reducing the effectiveness of the pump tank (if placed in drip pump tank). Certain States do require automated electronic flushing. Please refer to your State codes.

11. ZONE VALVES

Used to divide single dispersal fields into multiple zones, these can be hydraulically activated index valves or electrical solenoid valves. Index valves are hydraulically operated, while solenoids use electricity.

12. WASTEFLOW HEADWORKS

WASTEFLOW Headworks is a pre-assembled unit including the filter, valves and pressure gauge in a box or on a skid. It is installed between the pump and the field. Be sure to insulate the box in freezing climates.

DESIGN PARAMETERS:

1. SELECT AREA

Select the area with careful consideration of the soil, the terrain and your State and County regulations. Be sure the field is not in a flood plain or bottom of a slope where excessive water may collect after rain. Surface water should be directed away from the proposed field area. Consider:

- Setbacks from water bodies, driveways, neighbors, wells....
- Restrictive limiting layers? Rock/Clay Shallow ground water? Seasonal high water?
- Is dripfield located at lowest point in the area? Check surrounding hills and valleys
- Is there any surface water coming in form neighbors?
- Is there any construction debris at the site?

2. WATER QUALITY

The source of sewage should be assessed for flow and constituents.

Maximum daily flows should be used for design flow rates and should include peak/safety factors. Pre-treatment facilities may be designed with flow equalization for situations with inconsistent flow characteristics.

Sewage with BOD, TSS or Oils and Grease levels in excess of normal residential sewage must be pre-treated to reduce effluent values for these constituents to residential levels prior to dispersal or custom design of loading rates will be necessary. Sources with very high levels of minerals or other abnormal chemical or physical characteristics require special consideration and custom design. If iron or iron bacteria are prevalent, please be sure to eliminate it upstream of the drip system with ozone, ultraviolet or chemical treatment.

3. SOIL APPLICATION DESIGN

Soil loading rates, as expressed in gallons per day per square ft., should take both percolation tests and soil and site evaluations into consideration. Soils classification data provided by USDA-NRCS can be used as a guideline, but these do not consider site specific variables. Soil loading charts are often provided by State and local health departments. We encourage you to be most conservative in estimating the soil loading rates. Non residential systems with multiple zones need to be more conservative due to the edge effect and larger actual daily flows being used in design rather than inflated flows that are most frequently used in single family home designs.

Note: This section is based on Subsurface Trickle Irrigation System for On-Site Wastewater Disposal And Reuse by B. L. Carlile and A. Sanjines. The basis of the information is from the Texas Health Department regulations. The rules in your County and State may vary.

The instantaneous water application rate of the system must not exceed the water absorption capacity of the soil. A determination of the instantaneous water absorption capacity of the soil is difficult, however, since the value varies with the water content of the soil. As the soil approaches saturation with water, the absorption rate reduces to an equilibrium rate called the "saturated hydraulic conductivity." Wastewater application rates should be less than 10 percent of this saturated equilibrium.

Even though the trickle irrigation system maximizes the soil absorption rate through the low rate of application, thus keeping the soil below saturation, there will be times when the soil is at or near saturation from rainfall events. The design must account for these periods and assume the worst case condition of soil saturation. By designing for a safety factor of 10 or 12, based on the saturated hydraulic conductivity, the system will be under-loaded most of the time but should function without surface failure during extreme wet periods.

By applying wastewater slowly for a few hours daily, particularly if applied in "pulses" or short doses several times per day near the soil surface where the soil dries the quickest would keep the soil absorption rate at the highest value and minimize the potential of water surfacing in poor soil conditions.

As stated previously, this design criterion will under-load the system at all times except when the soil is at or near saturation from rainfall. If designing for an efficient irrigation system, the water supply may not be sufficient to meet the demands of a lawn or landscaped area during peak water demand months. This problem can be overcome by either of two solutions: add additional fresh-water make-up to the system during the growing season to supply the needed water for plants in question; or split the system into two or more fields with necessary valves and only use one of the fields during the peak water demand months and alternate the fields during winter months or extremely wet periods, or use both fields simultaneously if the pump capacity will so allow.

NOTES:

- The chart below is provided as a guide only. States and Counties may have regulations that are different. Check your State guidelines and consult with your local health department.
- Problems with drip dispersal fields occur when soils are misinterpreted. If in doubt, choose the more restrictive soil type from the table above.
- "Soil type" should be based on the most restrictive layer within two feet of the dripline. In many soils 1-ft. vertical separation from the limiting layer has proven successful with secondary treated effluent. Geoflow recommends you follow State and Local guidelines.

TABLE 1**DRIP LOADING RATES CONSIDERING SOIL STRUCTURE.**

Table 1 is taken from the State of Wisconsin code and was prepared by Jerry Tyler.

Provided for guidelines and budgeting purposes. Refer to your local regulations and qualified soil scientists to determine best loading rates.

Soil Textures	Soil Structure	Maximum Monthly Average BOD₅<30mg/L TSS<30mg/L (gallons/ft²/day)	Maximum Monthly Average BOD₅>30mg/L TSS>30mg/L (gallons/ft²/day)
Course sand or coarser	N/A	1.6	0.4
Loamy coarse sand	N/A	1.4	0.3
Sand	N/A	1.2	0.3
Loamy sand	Weak to strong	1.2	0.3
Loamy sand	Massive	0.7	0.2
Fine sand	Moderate to strong	0.9	0.3
Fine sand	Massive or weak	0.6	0.2
Loamy fine sand	Moderate to strong	0.9	0.3
Loamy fine sand	Massive or weak	0.6	0.2
Very fine sand	N/A	0.6	0.2
Loamy very fine sand	N/A	0.6	0.2
Sandy loam	Moderate to strong	0.9	0.2
Sandy loam	Weak, weak platy	0.6	0.2
Sandy loam	Massive	0.5	0.1
Loam	Moderate to strong	0.8	0.2
Loam	Weak, weak platy	0.6	0.2
Loam	Massive	0.5	0.1
Silt loam	Moderate to strong	0.8	0.2
Silt loam	Weak, weak platy	0.3	0.1
Silt loam	Massive	0.2	0.0
Sandy clay loam	Moderate to strong	0.6	0.2
Sandy clay loam	Weak, weak platy	0.3	0.1
Sandy clay loam	Massive	0.0	0.0
Clay loam	Moderate to strong	0.6	0.2
Clay loam	Weak, weak platy	0.3	0.1
Clay loam	Massive	0.0	0.0
Silty clay loam	Moderate to strong	0.6	0.2
Silty clay loam	Weak, weak platy	0.3	0.1
Silty clay loam	Massive	0.0	0.0
Sandy clay	Moderate to strong	0.3	0.1
Sandy clay	Massive to weak	0.0	0.0
Clay	Moderate to strong	0.3	0.1
Clay	Massive to weak	0.0	0.0
Silty clay	Moderate to strong	0.3	0.1
Silty clay	Massive to weak	0.0	0.0

4. DEPTH AND SPACING

WASTEFLOW systems usually have emitter lines placed on 2 foot (600 mm) centers with a 2 foot emitter spacing such that each emitter supplies a 4 sq. ft (0.36 m²) area. These lines are best placed at depths of 6-10 inches (150 - 250 mm) below the surface. This is a typical design for systems in sandy and loamy soils with a cover crop of lawn grass. Closer line and/or emitter spacing of 12 inches is used on heavy clay soils or very coarse sands where lateral movement of water is restricted. Using closer spacing should not reduce the size of the field.

5. SOIL LAYERS AND TYPES

The shallow depth of installation is an advantage of the subsurface dripfield since the topsoil or surface soil is generally the most biologically active and permeable soil for accepting effluent. The topsoil also dries the fastest after a rainfall event and will maintain the highest water absorption rate. The quality and homogeneity of the soil may present a problem. If the soil was not properly prepared and there are pieces of construction debris, rocks and non-uniform soils, it is very difficult to obtain uniform water spread. In many cases, particularly if the soil is compacted, soil properties can be greatly improved by ripping and disking.

6. ADDING FILL TO THE DISPERSAL FIELD

Some dispersal sites require additional soil be brought in for agronomic reasons or to increase separation distances from the restrictive layer. Restrictive layers stop or greatly reduce the rate of downward water movement, as a result surfacing may occur during part of the year. In soils with high water tables treatment is minimized due to a lack of oxygen.

Placing drip lines in selected fill material above the natural soil provides an aerated zone for treatment. Dispersal however still occurs in the natural soil and the field size must be based on the hydraulic capability of the natural soil to prevent hydraulic overload.

Any time fill material is to be used, the area to receive the fill should have all surface grasses and other organic material removed or it must be incorporated into the natural soil to prevent an organic layer from forming and restricting downward water movement. Removal must be performed under dry conditions. Divert surface and subsurface water prior to adding fill.

Soils to be used should be determined by a soils expert. Uniform soil material with good structure should be chosen. Avoid platy or massive materials with no structure.

The fill material should be applied in shallow layers with the first 4 to 6 inches incorporated into the natural soil to prevent an abrupt textural interface. Placement of fill should be uniform so preferential bypass flows do not occur. Soil should not be compacted. Continue this process until all fill has been incorporated.

The fill area should be left crowned to shed surface water and may need diversion ditches or some other devices to prevent surface water from infiltrating. The entire fill area should have a vegetative cover to prevent erosion. If possible, allow the fill to set at least seven to ten days before installing WASTEFLOW dripline.

It is generally agreed that fill should not be used on slopes greater than 20% unless means for controlling erosion, such as netting, are used. Consult a soils engineer on a case by case basis.

7. SLOPES OR HILLY SITES

A. High Points and siphoning

A potential problem with buried drip lines is siphoning dirt into the emitters when the pump is switched off. For this reason:

- i) At least one vacuum breaker should be installed at the highest point in each zone. It is best practice to install one at the high point of the supply and one at the high point of the return manifold.
- ii) Drip lines should be connected at the end to a common return line with a flush valve.
- iii) Run dripline along a contour if at all possible. Avoid installing lines along rolling hills where you have high and low points more than 3 ft. off contour along the same line. If the dripline is installed over a ridge, as shown below, connect all the high points together and install a vacuum breaker on the connecting line.

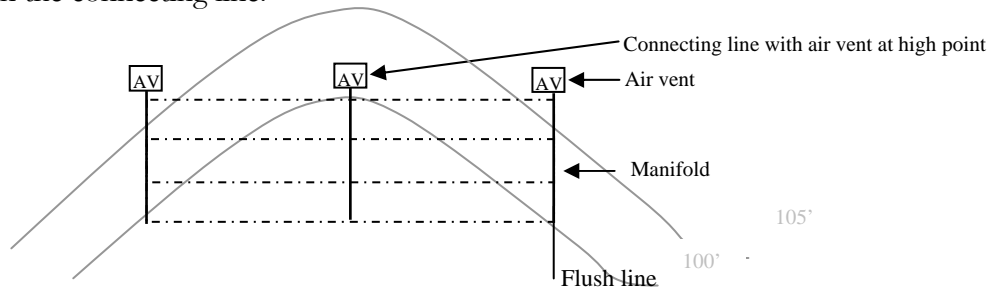

B. Dripline Pressure Tolerances

As water travels through a manifold or uphill, pressure decreases, or conversely, if water moves downhill pressure increases, which can affect the flow variation between the first dripline and the last dripline on the manifold.

WASTEFLOW Classic: The Classic dripline can be operated in a range of 10 to 45 psi, however too wide a variance in the pressure in a single field will result in too high a variance in flow within that field. As a rule of thumb, if the level variation within a WASTEFLOW Classic zone exceeds six feet, individual pressure regulators should be placed for each six-foot interval.

WASTEFLOW PC: PC dripline can tolerate very large height variations provided the pressure remains within the 7 to 60 psi range, and preferably within 10 to 45 psi.

C. Low Head Drainage

At the end of each dosing cycle, consideration must be taken for gravity. Where is the water going to drain when the pump shuts off? Water in the dripline will flow down to the lowest point within the drip zone. This is called "low head drainage." Use the following precautions to mitigate low head drainage.

- i. The dripline should run along the contour if at all possible because water will run to the lowest point of the line every time the pump is turned off. If the lowest point in the line is in the middle of the lateral, there will be excess flow at this point.

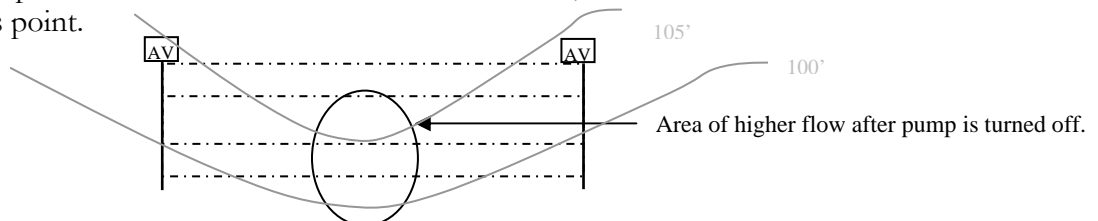

- ii. Have the dripline pass over an elevated berm between the manifold and beginning of the tubing to reduce gravity flow out of the lateral. In looped systems, elevating the loop will keep the effluent in its respective run.

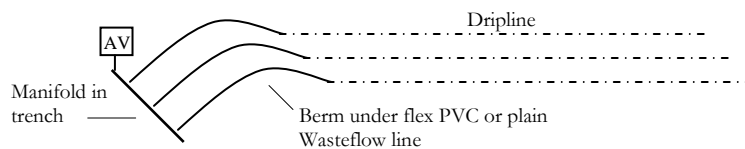

- iii. Use check valves or multiple zones to isolate the drip laterals. Check valves should only be used if there is no risk of freezing in the manifolds. They are placed on the supply and return manifolds coupled with an airvent on the downhill side. If unsure, as a rule of thumb, use a maximum of 1500 ft of Geoflow dripline within each zone or section.
- iv. Install short manifolds with fewer longer dripline runs.
- v. Slope the supply and return manifolds down to the pump tank so the effluent drains back down to the tank when the pump is turned off. Open the zone valves fully to drain the lines quickly.

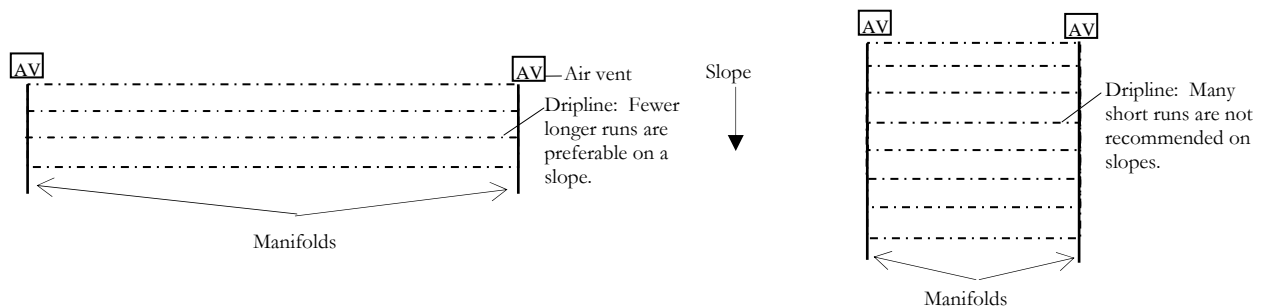

Concentrate drip lines at the top of the hill with wider spacing towards the bottom. In the case of compound slopes consult a professional irrigation designer or engineer.

8. MULTIPLE ZONES

Drip dispersal fields can be divided into multiple zones or sections with solenoid valves or index valves for the following reasons:

- o Steep slopes with a risk of low head drainage can be subdivided to distribute the water at system shut-down more uniformly in the field.
- o Smaller zones reduce the required flow per minute which consequently reduces the size of the pump , valves, filters, supply and return lines.

- Subdividing the field is a tool used to achieve the optimum ranges required to efficiently operate the pumps, filters and valves.
- If the dispersal field is located in multiple areas on the property.
- To accommodate varying soils or vegetation on a single site.

Note. On multiple zones, a single Wasteflow Headworks can be used for filtration and flushing by placing zone valves downstream of the Headworks box. All zones would require a check valve on the individual flush lines upstream of each line joining a common flush line to keep flush water from one zone entering any other zone during the flush cycle. (See Geoflow Design Detail No. 588)

If the effluent has not been through secondary treatment, then each zone should have a dedicated filter or Wasteflow Headworks.

9. FLUSHING DESIGN

Proper flushing of the drip system is critical for proper long term operation. Manual flushing of mains should be facilitated by provision of cleanouts to allow sequential flushing from the pump outward. For the Dripfield Automatic flushing is recommended and should be designed considering the following key points:

- Geoflow's Wasteflow dripline includes GeoShield, a biocide lining to prevent slime accumulation, and the system should be designed to flush at minimum 0.5 fps flow velocity.
- Minimum volume flushed should be 1 volume of dose mains, dose manifold and Dripline.
- Flush time should allow for system pressurization prior to flushing, or add time for pressurization to flush time.
- The flush return should be in a visible location. One option is to position the return over the septic tank inlet tee.
- Ideal location to return field flush flow is to the upstream side of a two compartment drip pump tank. Drip pumps would be in the downstream side of the tank. Flush return flows must not adversely impact treatment system performance; minimize disturbance in the return tank and be sure to not overload secondary treatment.
- Flush frequency at average flows should be minimum 1 per day.

10. WINTERIZATION

Buried drip systems can be safely used in cold climates. However, where severe freezing conditions may be an issue the designer should exercise special care, and some key requirements must be met:

- The dripline itself is made of polyethylene and not susceptible to freezing. It drains through the emitters so it will not be full of water after pumps are turned off.
- All Manifolds and mains must be laid to drain rapidly, and/or buried below frost depth and/or insulated. Be sure drain valve on flush line remains open long enough for entire field to drain. Control system must adequately control drain back
- Remove the check valve at the pump.
- Insulate equipment boxes, including Headworks box or filter and field flush valve boxes as well as zone dosing valves, pressure regulator and air vacuum relief valves. Use closed-cell insulation such as Perlite in a plastic bag. Place metal pins near, or in, the boxes to help locate them when under snow.
- In severe freezing conditions use heat tape or small heaters on PVC and PVC parts.

- When installing PVC supply and return lines and manifolds be sure there are no dips in the lines. This can be avoided by using large diameter pipes (over 2") or by using schedule 80 pipe.
- Air valves must be installed in insulated sealed valve boxes with drain rock sump extending below frost line. The top of air vacuum relief valves must be no higher than soil surface.
- If using an index valve to split field zones, be sure it is capable of self-draining.
- WASTEFLOW lines will self-drain through the emitters into the soil. If the cover crop over the dripfield is not yet adequately established, add hay or straw over the field for insulation.
- Mark the valve box with a metal pin so you can find it in the winter when covered in snow.
- If using manual filter flush valves or manual field flush valves, they should be left cracked open slightly to provide for rapid drainage of the flush line in freezing conditions.
- Fields dosed with relatively small quantities of effluent are more likely to freeze than those dosed with design quantities. If winter use is less than summer use, then only use proportional number of fields to maintain water application rates in the field being dosed.
- Install Dripline with minimum 20cm (8") cover.
- Maintain forest or shrub vegetation in dripfield wherever possible.
- Maintain organic soil cover, where occurring.
- Use organic material to assist in insulation of dispersal area for first winter.
- Trap snow over system, and do not allow packing of snow.
- Do not install near roads or driveways etc.
- Keep effluent warm:
 - Install all tanks in insulated "heat island" at house or other location.
 - Do not use continuous flush systems.
 - Use effluent heaters where seasonal use or cold water use is problematic.

11. LIGHTNING PROTECTION

A direct lightning strike on your valve, controller or wire is going to cause unpreventable damage. It is apparently very difficult to completely prevent electricity from spreading as it jumps across air, runs along electrical wires and may even travel along your water pipes. Power fluctuations can be prevented. The controllers are built to take some electrical surge and pass it through to the ground without damage. This requires a ground wire connected to a grounding stake driven deep into the ground. The best protection would be to use a separate ground wire or rod, not the third ground wire in the building's electrical wiring circuits. If you are installing this system in an area with frequent lightning storms, we advise you to install a separate grounding rod for each field controller installed according to the current version of the National electric Code or as prescribed by local zoning ordinances

12. REUSE FOR IRRIGATION

A good vegetative cover is an advantage to prevent erosion from the field and utilize water applied to the rooting zone. Sites should be planted or seeded immediately after installation. Grasses are particularly suitable for this application. Most lawn grasses will use 0.25" to 0.35" (6.3-8.9mm) of water per day during the peak growing season. This calculates to be about 0.16 to 0.22 gal/ft²/day. By over-seeding lawns with winter ryegrass, this use efficiency can be continued through much of the

year. For vegetation using 0.16 to 0.22 gal/ft²/day by evapotranspiration, a sewage flow of 1000 gallons per day would supply the water needs of a landscaped area of 4600 to 6400 sq. ft. without having to add fresh water. For areas larger than this, the plants will suffer water stress during the hot months unless additional fresh water is applied.

13. WATER APPLICATION FORMULA

To determine the rate of application for various drip irrigation designs, use the following formula:

Water application (inches per hour) = (231 × (emitter flow rate gph)) / ((Emitter spacing inches) × (dripline spacing inches))

Example: Dripline with 1.3 gph flow rate emitters spaced 24" apart and dripline spaced 24" apart.

$$\text{Water application} = (231 \times 1.3) / (24 \times 24) = 0.52 \text{ inches of water per hour.}$$

WORKSHEET:

The following worksheet is a simplistic guideline and is available as an Excel spreadsheet. It can be downloaded from Geoflow’s homepage at www.geoflow.com. To calculate the area required for your drip dispersal system you must know:

1. the quantity of effluent to be disposed of (in gallons per day) and
2. the soil acceptance rate (i.e. gallons per day per square foot).

Make a sketch of the dispersal area with contour lines.

WORKSHEET 1 - DISPERSAL FIELD DESIGN FOR SINGLE ZONE

Worksheet Dispersal Field	Formula
A. Quantity of effluent to be dispersed per day _____ <i>gpd</i>	
B. Soil type or hydraulic loading rate _____ <i>loading rate (gal/sq. ft./ day)</i>	<i>Based on soil analysis</i> <i>Refer to State or Local regulations. If none, refer to Table 2 on page 10</i>
C. Determine the total area required _____ <i>square ft</i>	<i>Divide gpd by loading rate. A/B</i>
D. Choose the spacing between each WASTEFLOW line and each WASTEFLOW emitter <i>i)_____ft. between WASTEFLOW lines</i> <i>ii)_____ft. between WASTEFLOW emitters</i>	<i>Standard spacing is 2 ft.</i>
E. How many linear feet of dripline in the total area? _____ <i>ft.</i>	<i>(Area / 2) for 2ft. line spacing. C/2.0 or</i> <i>(Area / 1) for 1 ft. line spacing., C/1.0 or</i> <i>(Area / 1.5) for 1.5ft line spacing. C/1.5</i>
F. Calculate the number of emitters _____ <i>emitters</i>	<i>(Linear ft. of dripline / 2) for 2 ft emitter spacing. E/2 or</i> <i>(Linear ft. of dripline / 1) for 1 ft emitter spacing. E/1 or</i> <i>(Linear ft. of dripline / 1.5) for 1.5 ft emitter spacing E/1.5</i>
G. Choose pressure compensating or Classic dripline _____ <i>WASTEFLOW Classic dripline or</i> _____ <i>WASTEFLOW PC ½ gph dripline</i> _____ <i>WASTEFLOW PC 1 gph dripline</i>	<i>See page 4 and Appendix 1 for details</i>

<p>Sketch a layout of the WASTEFLOW lines in the dispersal plot to make sure that the maximum lateral length of each WASTEFLOW line is not exceeded. Count number of laterals for use in flushing velocity below.</p>	<p>See Maximum Length of Run table in Appendix 1.</p>								
<p>H. Determine dripfield pressure _____ psi</p>	<p>Standard pressure is 20 psi.</p> <p>WASTEFLOW Classic systems need between 15 and 45 psi (34.7 and 104 ft.) at the start of the dripfield.</p> <p>WASTEFLOW PC systems need between 10 and 45 psi (23.1 ft. to 104 ft.) at the start of the dripfield.</p>								
<p>I. Determine feet of head required at dripfield _____ ft. of head</p>	<p>Multiply pressure by 2.31 to get head required.</p> <p>$H \times 2.31$</p>								
<p>J. What is the flow rate per emitter? _____ gph / emitter</p>	<p>See WASTEFLOW flow rates in Appendix 1.</p>								
<p>K. Determine total dose flow for the area _____ gph _____ gpm</p>	<p>Number of emitters multiplied by the emitter flow rate at the design pressure.</p> <p>$Gph = \text{No of emitters (F)} \times \text{gph per emitter (J)}$</p> <p>$Gpm = gph / 60$</p>								
<p>L. Count dripline laterals in the zone _____ laterals</p>	<p>1 lateral = connection from supply line to return line regardless of the number of loops</p>								
<p>M. Determine additional flow required to flush the zone _____ flush velocity _____ gph _____ gpm</p>	<p>Number of dripline laterals (L) multiplied by flush velocity multiplier:</p> <table border="1"> <thead> <tr> <th><u>Flush Velocity</u></th> <th><u>Multiplier</u></th> </tr> </thead> <tbody> <tr> <td>1/2 ft/sec.</td> <td>0.37</td> </tr> <tr> <td>1 ft/sec</td> <td>0.74</td> </tr> <tr> <td>2 ft/sec</td> <td>1.48</td> </tr> </tbody> </table>	<u>Flush Velocity</u>	<u>Multiplier</u>	1/2 ft/sec.	0.37	1 ft/sec	0.74	2 ft/sec	1.48
<u>Flush Velocity</u>	<u>Multiplier</u>								
1/2 ft/sec.	0.37								
1 ft/sec	0.74								
2 ft/sec	1.48								
<p>N. Total Flow required to flush zone _____ gpm</p>	<p>$M + K$ in gpm</p>								

PSI = Ft. of head divided by 2.31

WORKSHEET 2 - FRICTION LOSS

Worksheet – Friction Losses	
Friction Loss from dose enable float through Hydraulic Unit	
Total flow rate for the zone (see N above)	_____ gpm
Headloss across headworks / filter (ft.)	_____ ft.
Diameter of supply line (inches)	_____ inches
Length of supply line from pump to hydraulic unit (ft.)	_____ ft.
Supply line equivalent fitting length (ft)	_____ ft.
Supply line friction loss(ft) See PVC friction loss chart in Appendix	_____ ft.
Static head loss from the dose enable float to headworks (ft)	_____ ft.
Total Ft of headloss from pump through hydraulic unit	_____ ft.
Supply lines Friction Losses	
Total Drip line flush flow rate for zone (see N above)	_____ gpm
Size of supply line (inches)	_____ in
Length of supply line (ft)	_____ ft.
Vertical Lift from headworks to dripfield	_____ ft.
Total Supply line friction loss	_____ ft.
	_____ psi.
	_____ ft.
Minimum pressure required at beginning of dripfield	
Headloss in Dripline during flushing	
Length of dripline lateral _____ ft.	
Headloss through dripline lateral (See dripline cut sheets in Appendix)	_____ ft.
Pressure at distal end of dripline lateral	_____ ft.
Return lines Friction Losses	
Zone flush flow rate in gpm (see M above)	_____ gpm
Size of return line (inches)	_____ in
Length of return line (ft)	_____ ft.
Vertical Lift from headworks to dripfield	
Total Return line friction loss	_____ ft.
Total Headloss	_____ ft
<p>Note: Pressure from pump to dripfield must be added to pressure required at dripfield.</p> <p>Note: Return line losses must be greater than pressure at distal end of dripline laterals.</p>	
Size of Pump	
Flow rate in gpm (N above) (highest flow rate for any zone)	
pump model	
volts/hp/phase	

SYSTEM INSTALLATION

1. INSTALLATION GUIDELINES

All Geoflow drip systems require:

- - Filtration with 120 mesh/130 micron
- - Filter flush valve
- - Field flush valve
- - 2 Air vents in each zone

All Wasteflow Classic drip systems requires pressure regulation

Handle your dripline and components with care. nano-ROOTGUARD® is temperature sensitive. To assure a long life, store the dripline out of direct sunlight in a cool place.

- All dripfield construction shall be done in accordance with Local rules and regulations.
- Protect the site prior to installation. Construction traffic and material stockpiling can change the soil profile. Fence off entire dripfield prior to any construction. No utilities, cable wire, drain tile, etc shall be located in dripfield.
- System is not to be installed when ground is wet or frozen. When the moisture in the soil is near the plastic limit (soils will ribbon and not easily crumble), it will be prone to smearing.
- Prior to construction note if any water is accessing the location of the dripfield. Dripfield should not be located at the low point of a site. Divert all downspouts and surface waters away from dripfield. If a curtain drain is to be used be sure it is serviceable and properly screened.
- Excavation, filling and grading should have been finished prior to installation of the subsurface drip system. Be sure to minimize soil disturbance when clearing and grubbing the dripfield. Preserve as many trees as possible. Use light track equipment for tree removal and grind out roots to below dripline depth rather than fully removing the entire root.
- Be sure you have everything required for the installation before opening trenches. Pre-assemble as many sets of components as practical above ground and in a comfortable place. Compression or Lockslip adapters should be glued to PVC tees, riser units should be pre-assembled, and the sub-main manifold with tees can be pre-assembled and used to mark the beginning and end of WASTEFLOW lines.

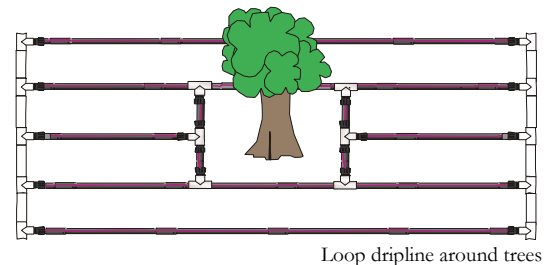

- For particularly tough soil conditions, soil moisture the day before opening trenches or installing WASTEFLOW. Remember it is much easier to install the system in moist soil. The soil should be moist but still allow the proper operation of the installation equipment and not cause smearing in the trenches. The soil surface should be dry so that the installation equipment maintains traction.
- Mark the four corners of the field. The top two corners should be at the same elevation and the bottom two corners should be at a lower elevation. In freezing conditions the bottom dripline must be higher than the supply and return line elevation at the dosing tank.
- Install the dosing tank. It is critical that the tank is waterproof. If installing a riser, check that it is watertight, and the entry and exit ports are completely sealed. In freezing conditions the

- dosing tank should be at the lowest elevation of the entire system. Lid should be placed at grade and water should be able to shed over it.
- Install zone valves; solenoid or hydraulic index valves.
 - Install the PVC supply line from the dosing tank, up hill through one lower and one upper corner stake of the dispersal field. Please refer to your State guidelines for depth of burial.
 - Paint a line between the two remaining corner stakes.
 - Install the Geoflow WASTEFLOW dripline from the supply line trench to the painted line, approximately 6” to 10” deep as specified. Upon reaching the painted line, pull the plow out of the ground and cut the dripline 1’ above the ground. Tape the end of the dripline to prevent debris from entering. The tubing expands in warm temperatures and contracts in cold temperatures. If installing during the warmer months, be sure to allow some play in the tubing so it will not pull out of the fittings when it gets cold. Continue this process until the required footage of pipe is installed. Geoflow dripline must be spaced according to specification (2 ft. is standard). Depth of burial of dripline must be consistent throughout the field. Take care not to get dirt into the lines.
 - If the system is looped, install the looped ends with Geoflow plain tubing or flex PVC. If in a cold climate be sure to pitch these slightly so they do not hold water and freeze. The loops are to be installed on the outside of the measured field.
 - Install the supply header with tees lined up at each Geoflow line. Hook up the Geoflow lines to the supply header. Do not glue WASTEFLOW dripline.

Lockslip Fittings Installations

- i) Hold the fitting in one hand and position the tubing with the other hand.
 - ii) Move the sleeve back, and push the tubing onto the exposed stem as far as possible.
 - iii) Push the sleeve out over the tubing and thread the sleeve onto tubing, as though tightening a nut to a bolt. Hand tighten. Do not use tools.
 - iv) Test the connection to make sure the sleeve threads have gripped the tubing tightly.
- Install the filter headworks between the field and the pump tank on the supply line. Insulate the box in freezing conditions. When using an open bottom headworks box, place a rodent barrier down first. This can be made from bricks, paving stones, chicken wire, 3 layers of filter fabric or a 6” minimum depth of 1” gravel. Support the pipes entering and exiting the headworks with gravel.
 - If using a pressure regulator, install it downstream of the filter headworks, just ahead of the dispersal field, on the supply line. Although the pressure regulator can be buried directly into the soil, it is preferable to install it inside a small valve box for easy access. *Insulate the box in freezing conditions.
 - Install the floats in the dosing tank and wire up to the timer control. The timer control should be set to pump no more than the design flow, do not set to match the treatment capacity.
 - Install the pump. Fill the dosing tank with fresh water and turn on the pump. Check for flow out the ends of all of the Geoflow lines. Let the pump run for about five minutes to flush out any dirt. Shut off the pump and tape the ends of the lines.
 - Dig the return header ditch along the line painted on the ground and back to the pre-treatment tank. Start the return header at the farthest end from the dosing tank. The return line must have slope back to the treatment tank, septic tank or pump tank.

- Install the return header and connect all of the Geoflow lines. Care must be taken not to kink the dripline.
- Install air vacuum breakers at the highest points in the dispersal field. Use pipe dope or Teflon tape and hand tighten. Use a 6” minimum depth of 1” gravel below the boxes to keep rodents out. Insulate in freezing climates.
- Install a ball or solenoid field flush valve on the return line to the pretreatment or pump tank unless a pre-assembled Wasteflow Headworks is being used. If a Headworks was installed on the supply line, connect the return line back through the Headworks box. Support the return pipe before it enters the Headworks with gravel. If using electric solenoid valves, connect the valve common and an individual output wire to the solenoid leads using watertight electrical connectors.
- Allow glue fittings 1 – 2 hours to set. Open the field flush valve and turn on the pump to flush lines then close the valve and check the field and all piping and connections for leaks. Turn off the system
- Check filters and valves for construction debris.
- Turn on the pump and check:
 - Pressure at the air vacuum breaker(s) against design pressure.
 - Check the pressure in the WASTEFLOW Headworks. It should be five psi or higher.
 - If pressure gauges are on each side of the filter, note these for benchmark differential pressure across the filter. If using a manual valve for field flushing, crack it open until at least one PSI is lost or design pressure is reached and leave in that position.
- Flow rates from flow meter or draw down on tank. Compare to design flow.
- Wet spots in the field. If any sections are particularly wet, determine if they are caused by faulty connections, drippers or shallow burial.
- Check that solenoid valves are functioning. Close the internal manual bleed after flushing the system. If solenoid will not close, first clean the solenoid with caution not to lose small spring, and if this fails, open the bonnet and clean the inside.
- Establish vegetation cover as specified.
- Provide owner with final as-built diagrams flow, measurements and pressure readings at startup.
- Provide controller records at startup, including elapsed time meter, pump counts, secondary override counts, high water counts and primary float counts.
- Solenoid Valve Installation and Operation
 - Wrap male adapters with 2 wraps of Teflon tape and thread the adapters into the valve inlet and outlet 1 turn past hand tight. CAUTION: over tightening may cause damage to the valve. The solenoid is located on the downstream side of the valve.
 - Flush the laterals by opening the internal manual bleed lever on the downstream side of the solenoid. Turn the flow control stem fully open (counterclockwise) for flow control models.
 - Check that solenoid valves are functioning.

TABLE 2. SUBSURFACE DRIP INSTALLATION METHODS

NOTE: Disturbing the soil may affect the pore structure of the soil and create hydraulic conductivity problems. Please consult with your soil scientist or professional engineer before making the installation technique decision.

INSTALLATION METHOD *	ADVANTAGES	DISADVANTAGES
a) Hand Trenching*	<ul style="list-style-type: none"> • Handles severe slopes and confined areas • Uniform depth 	<ul style="list-style-type: none"> • Slow • Labor intensive • Disrupts existing turf and ground • Back fill required
b) Oscillating or vibrating plow . Use the type that inserts the dripline directly in place, not one that pulls the dripline through the soil.	<ul style="list-style-type: none"> • Fast in small to medium installations • Minimal ground disturbance • No need to back fill the trench 	<ul style="list-style-type: none"> • Depth has to be monitored closely • Cannot be used on steeper slopes(>20%) • Requires practice to set and operate adequately • Tends to "stretch" pipe. Shorter runs are required
c) Trenching machine: Ground Hog, Kwik-Trench, E-Z Trench*	<ul style="list-style-type: none"> • Faster than hand trenching • May use the 1" blade for most installations • Uniform depth 	<ul style="list-style-type: none"> • Slower, requires labor • Disrupts surface of existing turf • Back fill required
d) Tractor with dripline insertion tool - see diagram 2.	<ul style="list-style-type: none"> • Fast • Little damage to existing turf because of the turf knife • Minimal ground disturbance • Does not stretch drip line • Adaptable to any tractor 	<ul style="list-style-type: none"> • The installation tool is designed specifically for this purpose.
e) Tractor mounted 3-point hitch insertion implement	<ul style="list-style-type: none"> • Fastest. Up to four plow attachments with reels • A packer roller dumps back soil on top of the pipe 	<ul style="list-style-type: none"> • Suitable for large installations only

* Installation methods are left to the discretion of the contractor and/or the engineer. Other installation methods may be used as long as care is taken to protect the tubing and the soil.

Diag. 2 Installation Tool

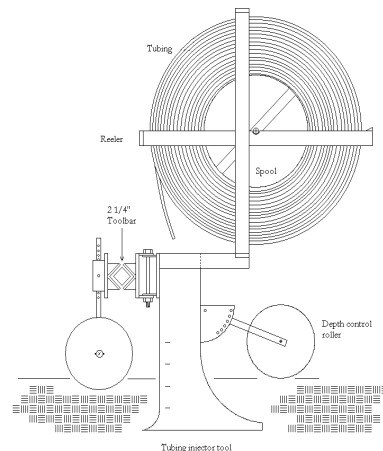

WORKSHEET 3 - AS BUILT SYSTEM DESCRIPTION.

1. Site name: _____
2. Site address including State: _____
3. Dripfield designed by: _____
4. Dripfield installed by: _____
5. Date of installation: _____
6. Daily design flow: _____ gpd.
7. Soil loading rate: _____
8. Is there secondary treatment on this job site? _____ Yes _____ No
If "Yes" to question 8 above, please name manufacturer and model number: _____
9. Number of zones in dripfield: _____ If more than 1 zone, circle the valve used Hydraulic or Solenoid
10. Amount of dripline installed in each zone:
Zone 1 _____ ft. Zone 2 _____ ft. Zone 3 _____ ft. Zone 4 _____ ft.
11. Wasteflow dripline model number &/or description: _____
12. Flow rate per zone:
Zone 1 _____ gpm. Zone 2 _____ gpm. Zone 3 _____ gpm. Zone 4 _____ gpm.
13. Depth dripline installed below grade: _____ inches
14. Pump manufacturer, model number and number of pumps: _____
15. Filter or Headworks model number &/or description: _____
16. Pressure in each zone:
Zone 1 _____ psi Location pressure measured: _____
Zone 2 _____ psi Location pressure measured: _____
Zone 3 _____ psi Location pressure measured: _____
Zone 4 _____ psi Location pressure measured: _____
17. Size of filter flush valve: _____ inches. Is the filter flush valve manual or automatic? _____
18. Size of field flush valve: _____ inches. Is the field flush valve manual or automatic? _____
If more than 1 zone, do the zones (a) share 1 flush valve or (b) does each zone have its own flush valve?
19. Was any fill material supplied on the dripfield? _____
If "yes" to 18 above describe fill quality and quantity added. _____

20. Please provide owner with as-built drawings, including but not limited to direction of drip lines, location of air vents, pressure regulators if applicable, Headworks (filter and valves) and pump tank.
21. Startup Controller readings:
ETM _____ Pump ct. _____ Secondary timer ct. _____ High alarm ct. _____ Primary ct. _____
22. Note how long it takes to drain return line in freezing climates, and set controller

SYSTEM MAINTENANCE

The best way to assure years of trouble free life from your system is to continuously monitor the system and to perform regular maintenance functions. For large systems or systems with a BOD > 30 mg/l automation of maintenance is essential. Inspection and maintenance should be performed every six months.

ROUTINE AND PREVENTATIVE MAINTENANCE

- Clean the filter cartridge. This may be done with a pressure hose. Vortex screen filter cartridge should be cleaned from the outside inwards, while the discs in the disc filter cartridge should be separated and then cleaned. If bacteria buildup is a problem, we advise first trying lye, and if the problem persists, soak the filter cartridge in a chlorine bath - a mixture of 50% bleach and 50% water.
- Open the field flush valve and flush the field for 3-5 minutes by activating the pump in “manual” position. Close the flush valve. On automatic solenoid valves the manual bleed lever should always be in the closed position and the dial on top should be free spinning. This allows it to open when pulsed electrically. Clockwise rotation closes valve.
- With the pump in the “manual” position, check the pressure in the drip field by using a pressure gauge on the Schrader valve located on the air vents and by reading the pressure gauge located in the Wasteflow Headworks box. The pressure should be the same as shown on the initial installation records. On systems with manual flush valves, close the field flush valve completely and then open the valve slightly until there is a 1-2 psi drop or design pressure is reached. This will allow the field to drain after each dose to prevent the manifold lines from freezing.
- Remove the lids on the vacuum breaker and check for proper operation. If water is seen leaking from the top of the vacuum breaker, remove the cap of the vacuum breaker and press down on the ball to allow any debris to be flushed out. Be careful not to come in contact with the effluent.
- Turn off the pump and reset the controller for auto mode.
- Periodically remove and clean the air vents, field flush and filter flush valves.
- Visually check and report the condition of the drip field, including any noticeable wetness.
- Treatment and distribution tanks are to be inspected routinely and maintained when necessary in accordance with their approvals.
- Record the elapsed time meter, pump counter, override counter, high-level alarm and power failures. This information can be obtained from the controller.

HOME OWNERS GUIDE FOR CARE AND MAINTENANCE OF GEOFLOW DRIP DISPERSAL FIELD

A drip dispersal system has been installed on your property for the subsurface dispersal of the effluent from your home.

The drip dispersal system consists of a series of 1/2" diameter drip tubing installed at a shallow depth of 6-10" below the ground surface. It is designed to effectively disperse the treated effluent in the ground with a combination of soil absorption and plant uptake. Your drip dispersal system will function for many years with only minimal maintenance being required, provided the following recommendations are followed:

- Establish landscaping (preferably a grass cover) immediately. This will stabilize the soil and allow for the grass to take up the water.
- Do not discharge sump pumps, footing drains or other sources of clear water to the system, except for the effluent discharge from your treatment system.
- Maintain all plumbing fixtures to prevent excess water from entering the dispersal system.
- Do not drive cars, trucks or other heavy equipment over the drip dispersal field. This can damage the drip components or the soil and cause the system to malfunction. Lawn mowers, rubber wheeled garden tractors and light equipment can be driven over the drip field.
- Do not drive tent stakes, golf putting holes, croquet hoops etc., into the dispersal field
- Contact your service company if your high water alarm should sound. The pump chamber is sized to allow additional storage after the high water alarm sounds but you should refrain from excessive water usage (i.e., laundry) until the system has been checked.
- After a temporary shut down due to a vacation or other reason, the treatment plant ahead of the drip field filter initially may not function effectively, resulting in the filter blocking. Refer to maintenance guidelines above to clean the filter.

Contact your service company if you notice any areas of excessive wetness in the field. In most cases, this is usually caused by a loose fitting or a nicked dripline and can be easily repaired. Note: There may be some initial wetness over the dripline following the system's installation. This should cease once the ground has settled and a grass cover is established

SITE INSPECTION LIST:

Contractor _____
Site Address _____
Date _____

Site observations

- 1 Is dripfield located at the lowest point in the site where all waters may pond?
- 2 Is there any water coming in from neighbors? Downspouts? Irrigation?
- 3 Construction debris anywhere near the site, or compaction from construction or other causes?
- 4 How wet is the field before digging?
- 5 Will effluent drain back to tank in freezing climates? If not, is equipment insulated from freezing?

Pump tank

- 1 Watertight?
- 2 At grade. Allow surface water to run off
- 3 Inlet and outlet lines to be laid in gravel or compacted soils.
- 4 Float tree designed for easy removal for service and adjustment
- 5 Float settings correct to design?
- 6 Pump set a few inches up from the bottom of the tank
- 7 Waterproof wire nuts used to wire pump junction box

Headworks - Filter and flush valves

- 1 Waterproof wire nuts used in wiring solenoid valves
- 2 Is filter large enough to handle flow? Is it appropriate for the treatment unit?
- 3 Clean filter and valves after construction.
- 4 Check filter every time system is serviced and clean filter element
- 5 Clean valves if they do not close properly. See if different valves have different toggles.
- 6 Insulate in freezing climates
- 7 Have minimum of 1/2ft depth of 1" gravel under the Headworks for drainage and to keep gophers out
- 8 Check pressure - across filter (if available)
- 9 Check pressure - on return line pressure should be as designed. Lower than 5 psi may be too low.

Zone valves

- 1 Index valves - Requires 10 gpm min. flow, needs to self drain in freezing climate
- 2 Solenoids - Clean after installation if they do not close properly.

Supply and return lines

- 1 Make sure they are supported going into and out of the Headworks.
- 2 No dips
- 3 Make sure water from dripline does not flow back into supply and return trenches

Dripline

- 1 On contour
- 2 Burial depth
- 3 Check for kinking and local undulations (low areas) in installed dripline
- 4 Flush lines during construction
- 5 Is there ponding on surface?
- 6 Cover crop over field?

Airvents

- 1 Point of pressure measurement
- 2 Insulate in freezing climates
- 3 Make sure they are not in a position for surface or subsurface water to enter the system
- 4 Check pressure at airvents. Should be as designed. Less than 7psi may be too low.

Return to?

- 1 Pump tank? Don't churn the tank on return
- 2 Pretreatment? Can the equipment handle the additional flow?

Controller

- 1 Check field programmable settings against design
- 2 Proper wiring of controller...wire floats and valves
- 3 Keep moisture from running up wire into controller

Notes

- 1 Use sheet for "As built" in Design Guidelines.
- 2 Keep a record of start-up pressures and system data screens

Comments:

TROUBLE SHOOTING GUIDE:

Symptom: High water alarm activates periodically (1-2 times/week). During other times the water level in the pump chamber is at a normal level

Possible cause: Peak water usage (frequently laundry day) is causing a temporary high water condition to occur.

Remedy: Set timer to activate the pump more frequently. Be sure to not exceed the total design flow. To avoid this, reduce the duration of each dose.

Remedy: Provide a larger pump tank to accommodate the peak flow periods.

Symptom: High water alarm activates during or shortly after periods of heavy rainfall.

Possible cause: Infiltration of ground/surface water into system.

Remedy: Identify sources of infiltration, such as tank seams, pipe connections, risers, etc. Repair as required.

Symptom: High water alarm activates intermittently, including times when it is not raining or when laundry is not being done.

Possible cause: A toilet or other plumbing fixture may be leaking sporadically but not continuously. Check water meter readings for 1-2 weeks to determine if water usage is unusually high for the number of occupants and their lifestyle. Also determine if water usage is within design range.

Remedy: Identify and repair fixture.

Symptom: High water alarm activates continuously on a new installation (less than 3 months of operation). Inspection of the filter indicates it is plugged with a gray colored growth. Water usage is normal.

Possible cause: Slow start-up of treatment plant resulting in the presence of nutrient in the effluent sufficient to cause a biological growth on the filter. This is typical of lightly loaded treatment plants that receive a high percentage of gray water (i.e., from showers and laundry),

Remedy: Remove and clean filter cartridge in a bleach solution. Add a gallon of household bleach to pump tank to oxidize organics. Contact treatment plant manufacturer for advice on speeding up the treatment process possibly by “seeding” the plant with fresh activated sludge from another treatment plant.

Symptom: Water surfaces continuously at one or more isolated spots, each one foot or more in diameter.

Possible cause: Damaged drip line or a loose connection is allowing water be discharged under pressure and therefore at a much greater volume than intended.

Remedy: Dig up drip line. Activate pump and locate leak. Repair as required.

Possible cause: If water is at base of slope, can be caused by low-head drainage.

Remedy: Install check valves and airvents in the manifolds to redistribute water in the system after pump is turned off. This is not advised for freezing climates where manifold drainage is required.

Symptom: A portion of the drip field closest to the feed manifold is saturated while the rest of the field is dry.

Possible cause: Insufficient pump pressure. A pressure check at the return manifold indicates pressure of less than 10 psi.

Remedy: Check filter and pump intake to insure they are not plugged. If they are, clean as require.

Remedy: Leaks in the system may be resulting in loss of pressure. Check for water leaks in connections and fittings or wet spots in the field. Also check air vents to insure they are closing properly. Repair as necessary.

Remedy: Pump is worn or improperly sized. Pressure at feed manifold is less than 15 psi. Verify pressure requirements of system and provide a new or larger pump. As an alternate approach, the drip field may need to be divided into two or more zones.

Possible cause: The duration of each dose is of insufficient length to allow the drip field to become pressurized before the pump shuts off (or runs for only a brief time before turning off).

Remedy: Increase the pump run time and decrease the frequency of doses. Always calculate (or observe during field operation) how long the system takes to fully pressurize and add this time to the design dosing duration.

Symptom: High water alarm begins to activate continuously after a long period (1-2 years) of normal operation. Inspection of the filter indicates it is plugged with a heavy accumulation of sludge.

Possible cause: A buildup of solids in the pump tank due to carryover from the treatment plant.

Remedy: Replace the filter cartridge with a clean cartridge. Check the pump tank and if an accumulation of solids is noted, pump the solids out of the pump tank. Also, check the operation of the treatment plant to insure it is operating properly.

Symptom: Water surfaces at several spots in drip field during dosing periods. Installation is recent, less than 6 months of usage and the soil is a moderate to heavy clay. Possibly, the installation was completed using a non-vibratory plow.

Possible cause: Smearing of the soil may have occurred during installation of drip line. Also, the “cut” resulting from the installation allows an easy path for the water to surface during dosing.

Remedy: In most cases the sod will compact naturally around the drip line and the surfacing will diminish and ultimately cease. To help, reduce the duration of each dose and increase the number of doses/day. Also, it will help to seed the area to encourage the development of a good root zone.

Symptom: Entire area of drip field is wet, soft and spongy. It appears to be totally saturated with water. Situation occurs during dry season when there is little rainfall.

Possible cause: Water being discharged to drip field exceeds design. Excess water may be a result of infiltration, plumbing leaks or excessive water usage.

Remedy: Check water meter, elapsed time meter, pump counter, override counter or high level alarm counter to determine if water usage is in excess of design. Check for leaks or infiltration. Repair leaks as required. Reduce water usage by installing water saving fixture.

Remedy: If water usage cannot be reduced, enlarge drip field as required.

Possible cause: Area of drip field was inadequately sized and is too small.

Remedy: Provide additional soil analysis to verify sizing and enlarge as required.

Valve Troubleshooting

Symptom: Valve will not open manually

Check water supply and any possible master or gate valves to insure they are open.

Check that the valve is installed with the arrow pointing in the downstream direction

Check that the flow control is fully open, counterclockwise.

Turn off the water supply. Remove the solenoid and check for debris blocking the exhaust port.

Turn off the water supply. Remove the cover. Inspect the diaphragm for damage and replace if necessary.

Symptom: Valve will not open electrically

Check voltage at controller for 24 VAC station.

Check voltage across the solenoid lead wires for minimum 21 VAC.

Make sure handle on top of valve is free spinning. Not all the way open or all the way closed.

If the valve still does not operate, electrically replace the solenoid.

Symptom: Valve will not close

Insure the manual bleed lever is in the closed position.

Check for leaks around the flow control, solenoid or between valve cover and body.

Turn off the water supply. Remove the solenoid and check for debris or damage to the exhaust port.

Turn off the water supply. Remove valve cover and inspect for debris under diaphragm or debris in diaphragm ports.

Symptom: Slow leak

Check for dirt or gravel embedded in the diaphragm seat.

Check actuator and exhaust fitting for proper seating.

SUBSURFACE DRIP DISPERSAL KEY COMPONENTS MINIMUM STANDARDS

Component	Standard	Notes
Dripline and blank Dripline	Designed specifically for wastewater use, with purple stripe and a turquoise inner lining or purple color	Do not use non-wastewater tubing or emitters.
	Biocide lining	Required to permit 0.5 fps flushing velocity
	Emitters impregnated with Treflan® or OBPA	Required to prevent root intrusion
Dripline installation depth	6" to 12" (15-30cm)	6" (15cm) standard.
Dripline minimum pressure	10 psi during dosing	Minimum pressure required to get flush water back to flush tank.
Dripline fittings	Lockslip fittings. Using barb couplings if Lockslip does not fit through installation shank.	Reduces risk of tubing splitting.
Flexible pipe for loops	1/2" IPS flexible PVC pipe	To avoid kinking
Air valves	1" for any drip area under 2500 emitters.	To assist in rapid pressurization, siphon break and to prevent suction of fines into emitters. Install in valve box with drain rock or pea gravel base. Install with no high or low points between valve and Dripline.
Supply mains	Design at 2-5 fps velocity for dosing flushing	
Pressure test ports	At manifolds, filter outlet, flush valve inlet.	
Check valves (if used)	To prevent back feed of sub areas from flush main, or to prevent drain down of one area to another.	Preferably ball style check valves provided with unions for service.
Control valves/flush valve	Contamination resistant solenoid operated hydraulic diaphragm valves	Three way solenoid with external piloting and filtration recommended for larger systems.
	Motorized ball valves	Installed above any water level. Preferred for freezing conditions.
Flush return	Preferred, to septic tank inlet tee with air gap for observation.	Must not cause scouring or disturbance in tank. May be returned to treatment plant inlet if appropriate.
Indexing valve (if used)	Install at high point of system or use check valves.	Consider minimum switching flow rate and head loss in hydraulic design.
Filter	Maximum aperture size 130 microns	
	Screen filters, maximum differential of 2 psi at peak flow rate	For small residential systems with STE do not use screen filters smaller than 1.5" to avoid excessive differential

Component	Standard	Notes
	Disc filters to include biocide impregnation in disc material.	To prevent grow through of slime.
	Manual clean disc filters to be sized to allow typical minimum one year operation between cleaning.	Screen filters should be self-flushing or self-cleaning.
	Differential pressure alarm/gage, set point 2psi	Optional. May be replaced by pressure test ports.
Pump relief valve	Pressure Sustaining or Relief valve designed to keep pressure within maximum for headworks and achieve pump cooling flow. To be used where pump maximum pressure in excess of 100 psi.	
Pump chamber	To meet minimum timed dose standards.	
Control panel	Timed dosing, with main dose at average flow, override at design flow and alarm for high level.	No dosing in excess of the Design flow.
	Alarm, audible and visual	For high level (optionally for filter differential)
	Low level cut off and alarm	To protect pump, with alarm.
	Drain down capability	For freezing conditions.
	Automatic flush capability.	Continuous flush is not recommended.
	Data logging capability	Record of events with time, day, date stamp.
Septic Tank treatment	To consistently achieve maximum BOD5 of 150 mg/L, TSS of 50 mg/L Oil and Grease of 15 mg/L	Must be provided with outlet barrier filter to 1/16". Recommended tank size 4 x design flow, minimum 3 x design flow.
Secondary treatment facility	To consistently achieve maximum BOD5 of 30 mg/L, TSS of 30 mg/L Oil and Grease of 15 mg/L	Must be provided with outlet barrier filter to 1/16" if there is risk of sludge escaping from plant.
Tanks	Meeting local and national regulatory standards. Watertight tested, with waterproof risers to grade.	Installed to meet standard practice.
Pipe and plumbing components	Designed and manufactured to resist the corrosive effects of wastewater and common household chemicals, and meet applicable ASTM standards.	
Valve boxes	Provide valve boxes for all valves and pressure test points. With pea gravel or gravel base and positive drainage. Frost protected where necessary. Mark valve box locations.	
Electrical components	Should comply with appropriate local and national regulatory requirements. The installation of all electrical components must comply with local Electrical Code. Control valves must be wired to manufacturer standards.	

PRODUCT SHEETS

<u>Product</u>	<u>Pages</u>
Wasteflow® dripline	34 - 37
Headworks	38 - 43
Pressure Regulators	44 - 45
Lockslip Fittings	46 – 47
Ball Check Valves	48 - 49
Air Vents	50 - 51
Solenoid Valves	52 - 54
PVC 40 Friction Loss Chart	55

Description

The flexible 1/2" polyethylene dripline has large emitters regularly spaced in the line. With the dripline hidden about six inches below ground, effluent is distributed slowly and uniformly, reducing ponding, even in difficult soils and hilly terrain.

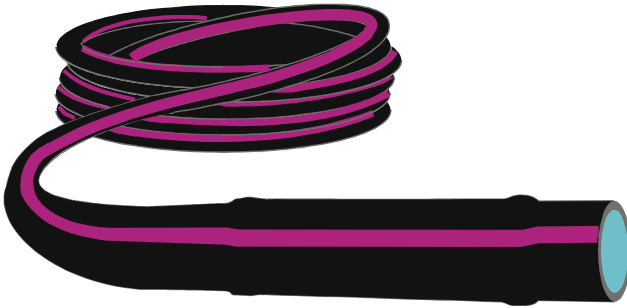

WASTEFLOW is built to last. It is guaranteed to be trouble-free from root intrusion with built-in nano-ROOTGUARD® protection, and the dripline wall is protected from organic growth with the *Geoshield* lining. WASTEFLOW provides uniform distribution. The emitters have a Coefficient of variation of less than .05.

Different flow rates, dripline diameters and emitter spacings can be special ordered.

Use 600 series compression adapters or lockslip fittings to connect the dripline to PVC pipe.

nano-ROOTGUARD® Protection

WASTEFLOW dripline features patented nano-ROOTGUARD technology to prevent roots from clogging the emission points. The pre-emergent, Treflan®, is bound into WASTEFLOW emitters when they are molded to divert roots from growing into the emitter outlet. The system is guaranteed against root intrusion for 15 years.

ANTI BACTERIAL Protection

Geoshield® is incorporated into the inner lining and emitters of WASTEFLOW dripline to prevent bacteria from growing on the walls of the tubing and emitters. It eliminates the need to scour the tubing. It is a tin based formula that defeats the energy system of microbial cells. This means smaller pumps or larger zones can be used with WASTEFLOW dripline than unprotected dripline.

PC vs. CLASSIC

Geoflow, Inc. offers WASTEFLOW dripline in both pressure compensating (WASTEFLOW PC) and non-compensating (WASTEFLOW Classic) models.

We recommend that WASTEFLOW PC be used when the advantages are of substantial economic value.

- a) Very long runs.
- b) Steep slopes. Systems should be designed for the dripline lateral to follow the contour. If this is possible, the extra cost of pressure regulators required for WASTEFLOW Classic would likely be less than the incremental cost of WASTEFLOW PC.
- c) Rolling terrain. If the difference in height from trough to peak exceeds six feet then WASTEFLOW PC should be used. Vacuum relief valves must be placed at the top of each rise.

WASTEFLOW PC and WASTEFLOW Classic can be interchanged to meet filter and zone flow requirements.

- WASTEFLOW is manufactured under US Patents 5332160,5116414 and Foreign equivalents.
- **Geoshield®** is a registered trademark of A.I.Innovations
- WASTEFLOW is a registered trademark of A.I.Innovation
- TREFLAN is a registered trademark of Dow Agro Chemicals.

WASTEFLOW CLASSIC

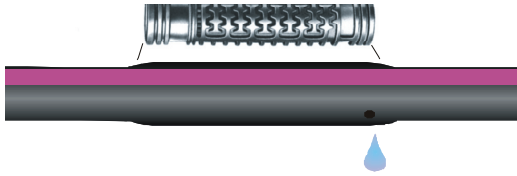

Available in 2 standard models

WF16-4-24 WASTEFLOW Classic 24"/1.3gph

WF16-4-12 WASTEFLOW Classic 12"/1.3gph

Alternate flow rates, diameters and spacing available upon request.

Flow Rate vs. Pressure

Pressure psi	Head ft.	ALL WASTEFLOW Classic Dripline
10 psi	23.10 ft.	.81 gph
15 psi	34.65 ft.	1.00 gph
20 psi	46.20 ft.	1.16 gph
25 psi	57.75 ft.	1.31 gph
30 psi	69.30 ft.	1.44 gph
35 psi	80.85 ft.	1.57 gph
40 psi	92.40 ft.	1.68 gph
45 psi	103.95	1.80 gph

WASTEFLOW Classic Specification

The dripline shall consist of nominal sized one-half inch linear low density polyethylene tubing, with turbulent flow drip emitters bonded to the inside wall. The drip emitter flow passage shall be 0.053" x 0.053" square. The tubing shall have an outside diameter (O.D.) of approximately .64-inches and an inside diameter (I.D.) of approximately .55-inches. The tubing shall consist of three layers; the inside layer shall be *Geoshield®* protection, the middle layer shall be black and the outside layer shall be purple striped for easy identification. The dripline shall have emitters regularly spaced 24" (or 12") apart. The turbulent flow emitters shall be molded from virgin polyethylene resin. The turbulent flow emitters shall have nominal discharge rates of 1.16 gallons per hour at 20 psi. The emitters shall be impregnated with Treflan® to inhibit root intrusion for a minimum period of fifteen years and shall be guaranteed by the manufacturer to inhibit root intrusion for this period. WASTEFLOW Classic dripline shall be Geoflow model number WF16-4-24 (or WF16-4-12).

Maximum Length of Run vs. Pressure

Flow variation +/- 5%

Pressure psi	Head ft.	Emitter Spacing		
		24"	18"	12"
10 psi	23.10 ft.	170'	165'	100'
15 psi	34.65 ft.	170'	165'	100'
20 psi	46.20 ft.	170'	165'	100'
25 psi	57.75 ft.	170'	165'	100'
30 psi	69.30 ft.	170'	165'	100'
35 psi	80.85 ft.	170'	165'	100'
40 psi	92.40 ft.	170'	165'	100'
45 psi	103.95 ft.	170'	165'	100'

Kd=0.9 Cv < .05

NOTE:

For rolling terrain use Geoflow's WASTEFLOW PC-SD, our slow drain anti-siphon dripline

Pressure Loss vs. Length of Run

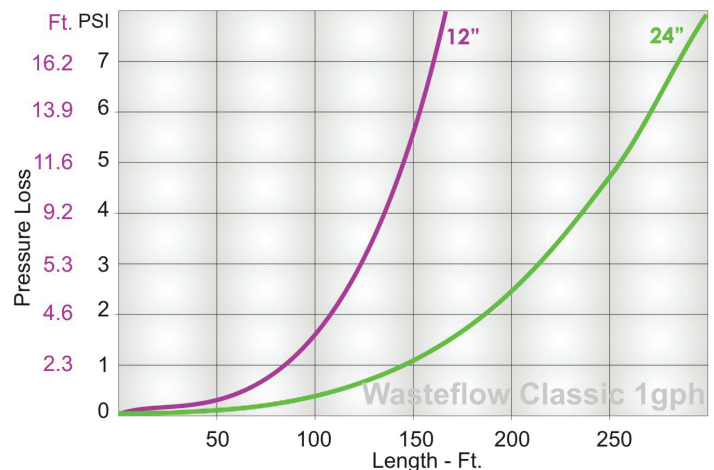

WASTEFLOW PC 1/2 gph

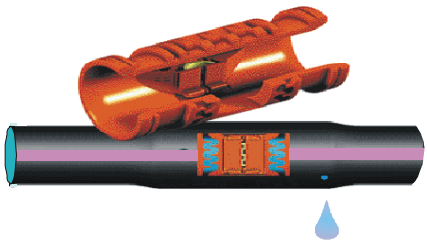

Standard products:

WFPC16-2-24 WASTEFLOW PC 24"/.53gph or 2lph
 WFPC16-2-18 WASTEFLOW PC 18"/.53gph or 2lph
 WFPC16-2-12 WASTEFLOW PC 12"/.53gph or 2lph
 Alternative spacing, flow rates and diameters available upon request.

Flow Rate vs. Pressure

Pressure	Head	ALL WASTEFLOW PC 1/2 gph dripline
7-60 psi	16-139 ft.	0.53 gph

Maximum Length of Run vs. Pressure

Allows a minimum of 10 psi in the line.
 Recommended operating pressure 10-45 psi.

Pressure psi	ft.	Emitter Spacing			
		6"	12"	18"	24"
10 psi	23.10 ft.				
15 psi	34.65 ft.		174'	260'	321'
20 psi	46.20 ft.	120'	229'	330'	424'
25 psi	57.75 ft.		260'	377'	478'
30 psi	69.30 ft.	150'	288'	415'	535'
35 psi	80.85 ft.		313'	448'	576'
40 psi	92.40 ft.	172'	330'	475'	612'
45 psi	103.95 ft.		354'	501'	651'
50 psi	115.5 ft.		363'	523'	675'
55 psi	127.05 ft.		377'	544'	700'
60 psi	138.6 ft.		403'	563'	727'

Kd = 2.070

NOTE:
 For rolling terrain use Geoflow's WASTEFLOW PC *SD*, our slow drain anti-siphon dripline

WASTEFLOW PC 1/2 gph PC Specification

The dripline shall consist of nominal sized one-half inch linear low density polyethylene tubing, with turbulent flow drip emitters bonded to the inside wall. The drip emitter flow passage shall be 0.032" x 0.045" square. The tubing shall have an outside diameter (O.D.) of approximately .64-inches and an inside diameter (I.D.) of approximately .55-inches. The tubing shall consist of three layers; the inside layer shall be a *Geoshield*® protection, the middle layer shall be black and the outside layer shall be purple striped for easy identification. The dripline shall have emitters regularly spaced 24" (or 18" or 12") apart. The pressure compensating emitters shall be molded from virgin polyethylene resin with a silicone rubber diaphragm. The pressure compensating emitters shall have nominal discharge rates of 0.53 gallons per hour. The emitters shall be impregnated with Treflan® to inhibit root intrusion for a minimum period of fifteen years and shall be guaranteed by the manufacturer to inhibit root intrusion for this period. 0.53 gph WASTEFLOW PC pressure compensating dripline shall be Geoflow model no. WFPC16-2-24 or WFPC16-2-18 or WFPC16-2-12.

Pressure Loss vs. Length of Run

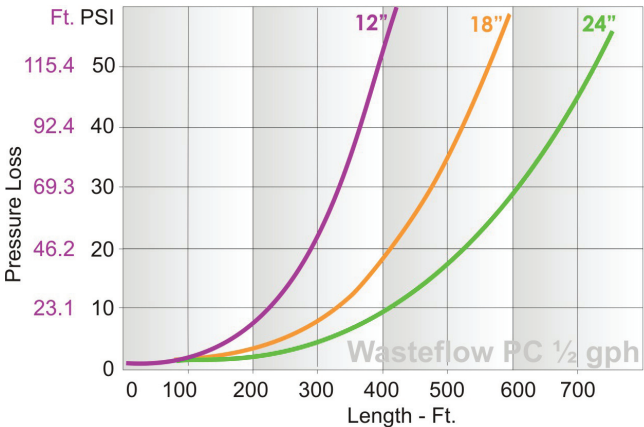

WASTEFLOW PC 1 gph

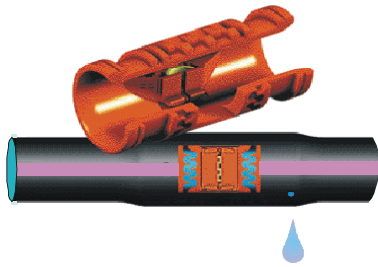

Standard Products:

WFPC16-4-24 WASTEFLOW PC 24"/1.02 gph or 4lph
 WFPC16-4-18 WASTEFLOW PC 18"/1.02 gph or 4lph
 WFPC16-4-12 WASTEFLOW PC 12"/1.02 gph or 4lph
 Alternative spacing, flow rates and diameters available upon request.

WASTEFLOW PC 1 gph PC Specification

The dripline shall consist of nominal sized one-half inch linear low density polyethylene tubing, with turbulent flow drip emitters bonded to the inside wall. The drip emitter flow passage shall be 0.032" x 0.045" square. The tubing shall have an outside diameter (O.D.) of approximately .64-inches and an inside diameter (I.D.) of approximately .55-inches. The tubing shall consist of three layers; the inside layer shall be *Geoshield*® protection, the middle layer shall be black and the outside layer shall be purple striped for easy identification. The dripline shall have emitters regularly spaced 24" (or 18" or 12") apart. The pressure compensating emitters shall be molded from virgin polyethylene resin with a silicone rubber diaphragm. The pressure compensating emitters shall have nominal discharge rates of 1.02 gallons per hour. The emitters shall be impregnated with Treflan® to inhibit root intrusion for a minimum period of fifteen years and shall be guaranteed by the manufacturer to inhibit root intrusion for this period. 1.02 gph WASTEFLOW PC pressure compensating dripline shall be Geoflow model number WFPC16-4-24 (or WFPC16-4-18 or WFPC16-4-12) .

Flow Rate vs. Pressure

Pressure	Head	ALL WASTEFLOW PC 1 gph dripline
7-60 psi	16-139 ft.	1.02 gph

Maximum Length of Run vs. Pressure

Allows a minimum of 10 psi in the line.
 Recommended operating pressure 10-45 psi.

Pressure psi	Pressure ft.	Emitter Spacing		
		12"	18"	24"
10 psi	23.10 ft.	95'	140'	175'
15 psi	34.65 ft.	115'	172'	211'
20 psi	46.20 ft.	146'	210'	265'
25 psi	57.75 ft.	171'	242'	315'
30 psi	69.30 ft.	180'	266'	335'
35 psi	80.85 ft.	199'	287'	379'
40 psi	92.40 ft.	211'	305'	385'
45 psi	103.95 ft.	222'	321'	429'
50 psi	115.5 ft.	232'	334'	431'
55 psi	127.05 ft.	240'	347'	449'
60 psi	138.6 ft.	249'	360'	465'

Kd = 2.070

NOTE:

For rolling terrain use Geoflow's WASTEFLOW PC *SD*, our slow drain anti-siphon dripline

Pressure Loss vs. Length of Run

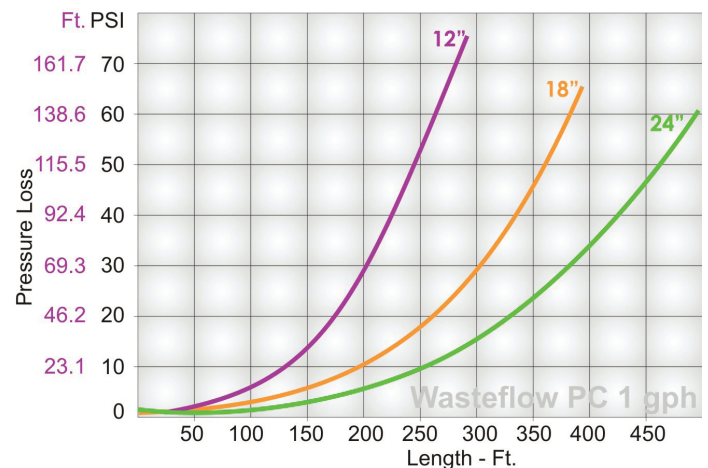

Look for the **Genuine Geoflow** stamp of quality

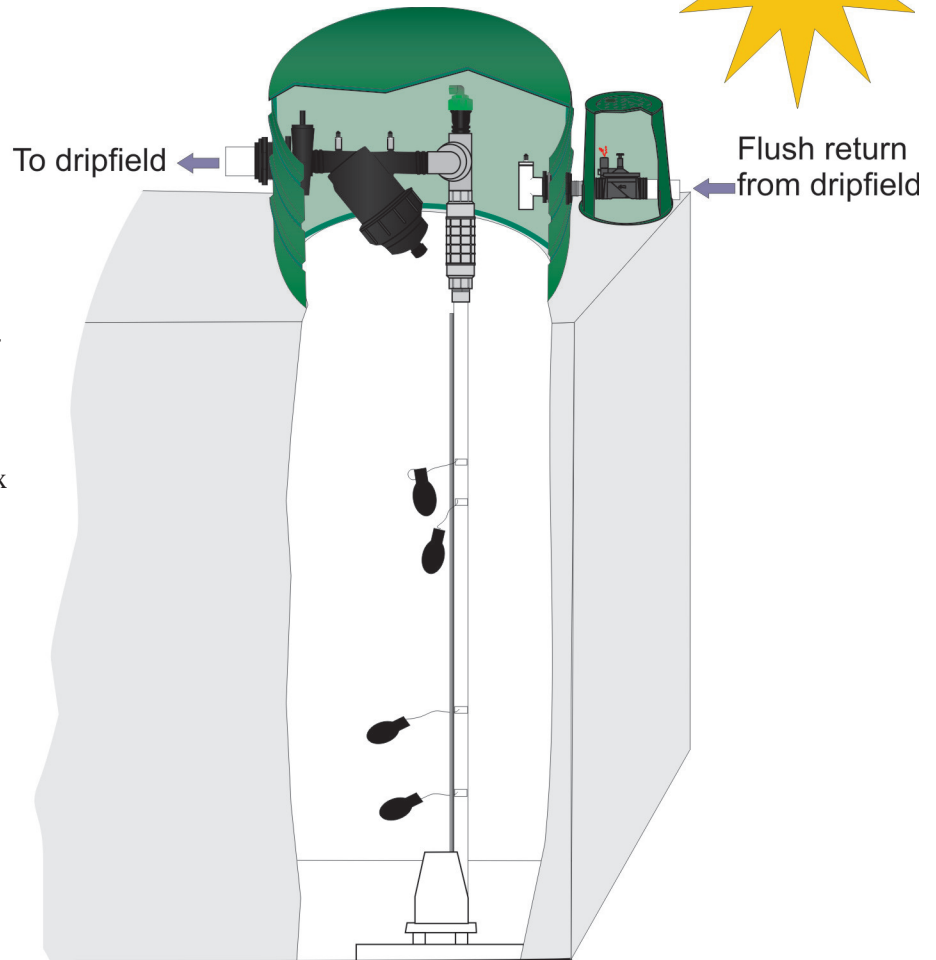

Description

Designed to fit inside the pump tank riser with a quick disconnect fitting for easy removal and servicing. No need to maintain the filter, and flush valve on your hands and knees. The entire filter and pump come out together. Available with either Geoflow's BioDisc or Vortex Screen filter. No need to bury a headworks box in the ground. No animals and flooding damage. Reduces freezing as it stays warmer inside the pump tank.

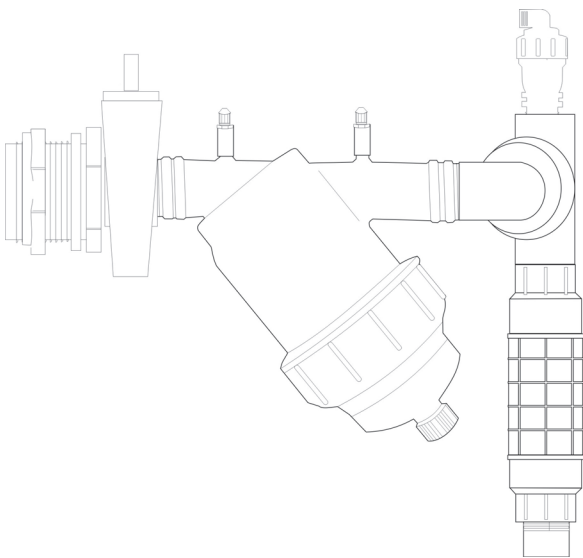

Design patent pending

Product Sheets-2011 InTankDripHeadworks 13B18.indd



Description

The Wasteflow Headwork is a pre-assembled unit including filters, valves, fittings and pressure gauges mounted inside a box for direct burial, or inside a pump tank riser. It is installed between the pump and the field to filter out fine particles from entering the treatment field, and to flush fine particles that may collect in the dripfield. recommended for maximum flow rate of 30gallons per minute and 600 gallons per day.

Process

During a *dosing cycle*, the wastewater exits the pump chamber and enters the inlet fitting of the Sporty Headworks. It passes through the filter before exiting the box and going to the dripfield zone that is open. Both the field flush valve and zone flush valves are closed at this time.

The water enters back into the Headworks through the return line, goes past the point to measure pressure and stops at the field flush valve.

During a *field flush* cycle, water enters the Headworks as above, the filter flush valve remains closed, but the field flush valve opens to allow water to circulate through the dripfield and return back into the return fitting of the headworks, past the pressure gage and through the field flush valve at an increased velocity than during normal dosing. The water passes through the field flush valve and down the flush line in the headworks to exit the headworks for return to the pump tank or pretreatment tank.

When *filter flushing*, the filter valve opens and the field flush valve is closed. While water passes through the filter to the field, part of the water is directed to the base of the filter, pushing solids down the screen, out of the filter, through the open filter flush valve, into the flush line in the ultra headworks to exit the headworks for return to the pump tank or pretreatment tank.

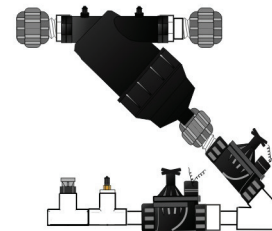
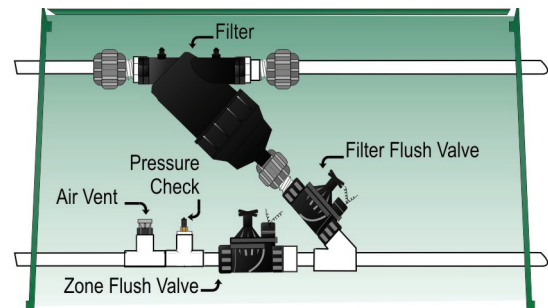

25"

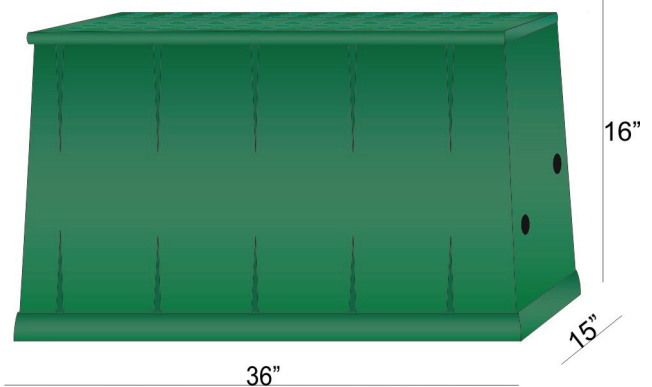

36"

16"

15"



Components Specification:

Enclosure: The Wasteflow Headworks Sporty enclosure shall be injection molded of structural foam polyethylene with a melt index of 10-12. The box shall be tapered with a top measurement of 25" x 16" and a bottom measurement of 33" x 23". The height shall be a minimum of 15" tall with a minimum wall thickness of 0.320". The body shall have a double wall at the top to cover seat area with a minimum thickness of 0.320". The cover seat area shall have structural support ribs on the underside of the seat. The bottom of the body shall have a 1.0" flange. The cover shall have an average thickness of 0.350".

Pressure Gauges: There shall be 3 points to measure pressure on the Sporty Wasteflow Headworks; one on each side of the filter and one on the return line. The pressure gauge is oil-filled and capable of registering pressure between 0-80 psi.

BioDisc filter (APBIODISC-150): The APBIODISC-150 filter body and discs shall be molded of polyethylene resins. The disc shall include **Geoshield®** anti-bacterial compound to protect the filter element against slime build-up. Filtration shall be 150 mesh/100 micron. The two piece body shall be capable of being serviced by untwisting and shall include an O-ring seal. The seals shall be manufactured from Nitrilo rubber. The inlet and outlet shall be 1.5 inch MPT. The UF disc filter shall be part number APBIODISC-150 as supplied by Geoflow, Inc.

Filter Flush Valve (SVLV-075): The solenoid valve shall be an electrically operated, normally closed, hydraulic valve with a 3/4" FIPT inlet and outlet. The globe shaped valve body is constructed of nylon reinforced molded epoxy resin and is waterproof, with an O-ring seal, and complies with NFC Class II circuit requirements for 24V a.c. operation. Metal parts shall be constructed of stainless steel, and the diaphragm shall be molded of natural rubber. The recommended operating pressure range is between 10-150 psi. Also available with manual flush where approved.

Field Flush Valve (SVLV-100 or SVLV-150):
The solenoid valve shall be an electrically operated, normally closed, hydraulic valve with a 1" FIPT inlet and outlet. The globe shaped valve body is constructed of nylon reinforced molded epoxy resin and is waterproof, with an O-ring seal, and complies with NFC Class II circuit requirements for 24V a.c. operation. Metal parts shall be constructed of stainless steel, and the diaphragm shall be molded of natural rubber. The recommended operating pressure range is between 10-150 psi. Also available with manual flush where approved.

1/2" Air Relief Valve (ARV-05): Molded plastic air vent with rubber ring shall be used on flush end of the Headworks. It shall be capable of allowing air in at 5 gpm.

Piping, Unions and Fittings shall be schedule 40 or schedule 80 grade PVC.

Flow vs. Pressure

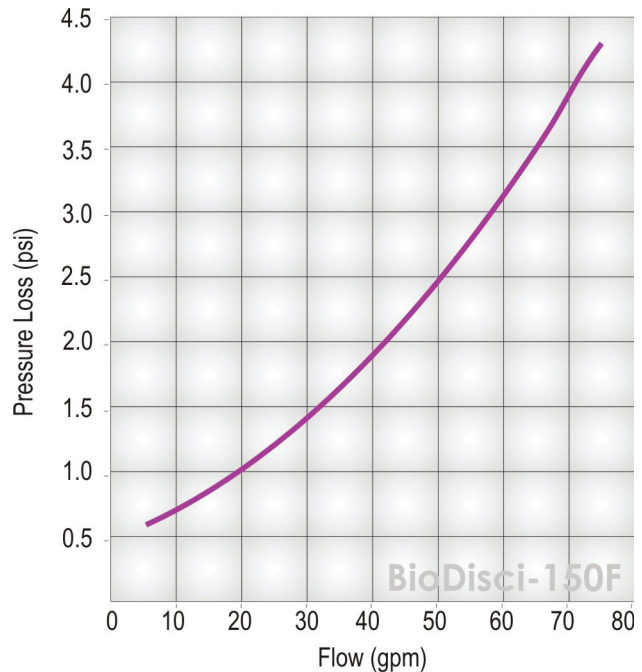

Description

The Wasteflow Headwork is a pre-assembled unit including filters, valves, fittings and pressure gauges mounted inside a box for direct burial, or inside a pump tank riser. It is installed between the pump and the field to filter out fine particles from entering the treatment field, and to flush fine particles that may collect in the dripfield. Recommended for maximum flow rate of 30gallons per minute and 600 gallons per day.

Process

During a *dosing cycle*, the wastewater exits the pump chamber and enters the inlet fitting of the Sporty Headworks. It passes through the filter before exiting the box and going to the dripfield zone that is open. Both the field flush valve and zone flush valves are closed at this time.

The water enters back into the Headworks through the return line, goes past the point to measure pressure and stops at the field flush valve.

During a *field flush* cycle, water enters the Headworks as above, the filter flush valve remains closed, but the field flush valve opens to allow water to circulate through the dripfield and return back into the return fitting of the headworks, past the pressure gage and through the field flush valve at an increased velocity than during normal dosing. The water passes through the field flush valve and down the flush line in the headworks to exit the headworks for return to the pump tank or pretreatment tank.

When *filter flushing*, the filter valve opens and the field flush valve is closed. While water passes through the filter to the field, part of the water is directed to the base of the filter, pushing solids down the screen, out of the filter, through the open filter flush valve, into the flush line in the ultra headworks to exit the headworks for return to the pump tank or pretreatment tank.

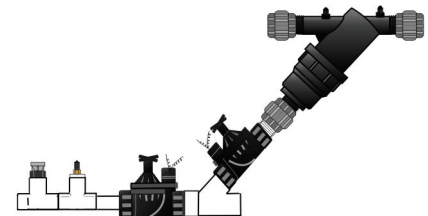
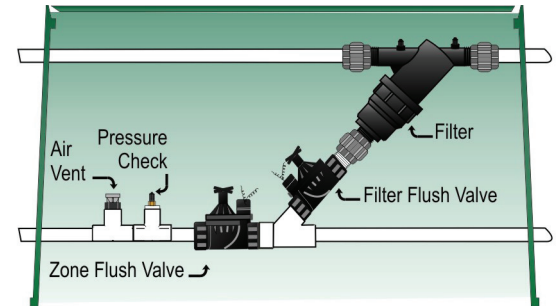

25"

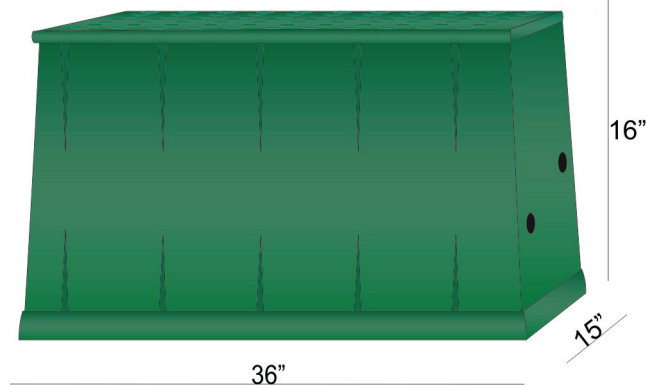

36"

16"

15"



Components Specification:

Enclosure: The Wasteflow Headworks Sporty enclosure shall be injection molded of structural foam polyethylene with a melt index of 10-12. The box shall be tapered with a top measurement of 25" x 16" and a bottom measurement of 33" x 23". The height shall be a minimum of 15" tall with a minimum wall thickness of 0.320". The body shall have a double wall at the top to cover seat area with a minimum thickness of 0.320". The cover seat area shall have structural support ribs on the underside of the seat. The bottom of the body shall have a 1.0" flange. The cover shall have an average thickness of 0.350".

Pressure Gauges: There shall be 3 points to measure pressure on the Sporty Wasteflow Headworks; one on each side of the filter and one on the return line. The pressure gauge is oil-filled and capable of registering pressure between 0-80 psi.

Vortex Screen Filter (AP4E-1F or AP4E1.5F or AP4E2F): The Y filter body shall be molded from glass reinforced engineering grade black plastic with a (1 or 1.5 or 2 inch) male pipe thread (MIPT) inlet and outlet. The two piece body shall be capable of being serviced by untwisting and shall include an O-ring seal. An additional 3/4 inch MIPT outlet shall be capable of periodic flushing. The 150 mesh filter screen is all stainless steel, providing a filtration area of (28.4 square inch for AP4E-1F, 60.8 square inch for AP4E-1.5F, 60.8 square inch for AP4E-2F). The screen collar shall be molded from vinyl. The filter shall be Geoflow Vortex Screen Filter model number (AP4E-1F or AP4E1.5F or AP4E2F).

Filter Flush Valve (SVLV-075): The solenoid valve shall be an electrically operated, normally closed, hydraulic valve with a 3/4" FIPT inlet and outlet. The globe shaped valve body is constructed of nylon reinforced molded epoxy resin and is waterproof, with an O-ring seal, and complies with NFC Class II circuit requirements for 24V a.c. operation. Metal parts shall be constructed of stainless steel, and the diaphragm shall be molded of natural rubber. The recommended operating pressure range is between 10-150 psi. Also available with manual flush where approved.

Field Flush Valve (SVLV-100 or SVLV-150): The solenoid valve shall be an electrically operated, normally closed, hydraulic valve with a 1" FIPT inlet and outlet. The globe shaped valve body is constructed of nylon reinforced molded epoxy resin and is waterproof, with an O-ring seal, and complies with NFC Class II circuit requirements for 24V a.c. operation. Metal parts shall be constructed of stainless steel, and the diaphragm shall be molded of natural rubber. The recommended operating pressure range is between 10-150 psi. Also available with manual flush where approved.

1/2" Air Relief Valve (ARV-05): Molded plastic air vent with rubber ring shall be used on flush end of the Headworks. It shall be capable of allowing air in at 5 gpm. Piping, Unions and Fittings shall be schedule 40 or schedule 80 grade PVC.

Pressure Loss:

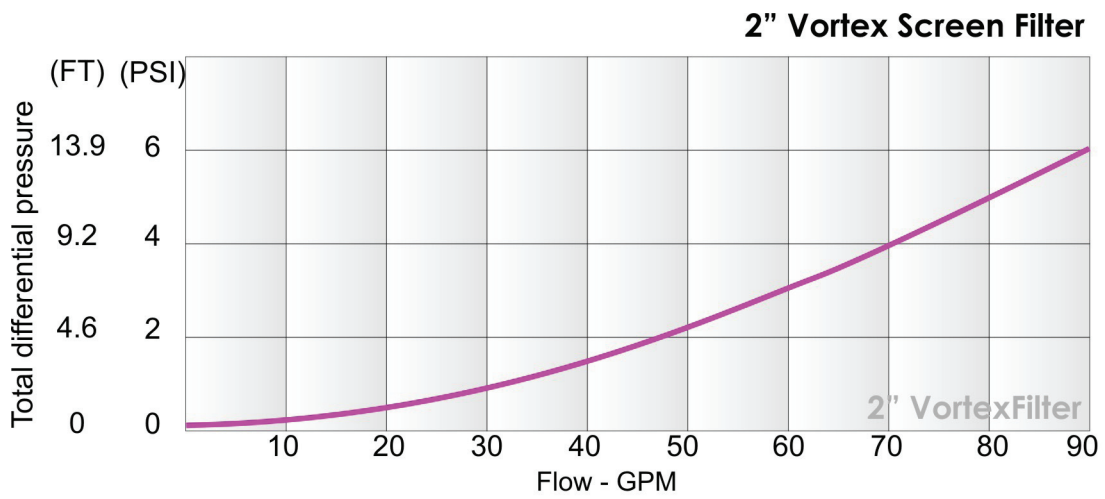
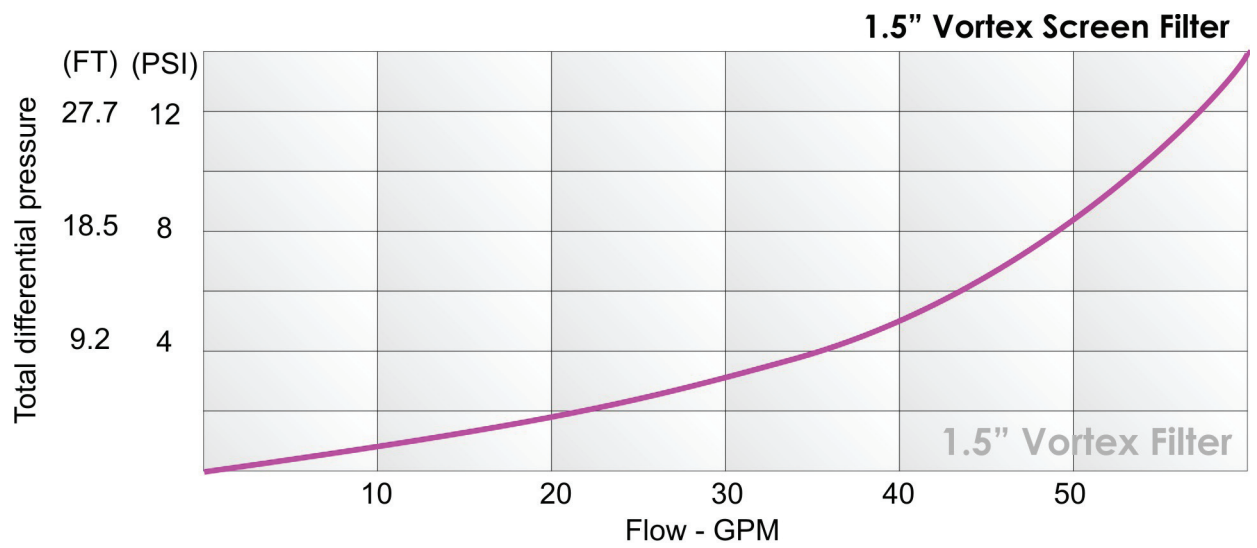
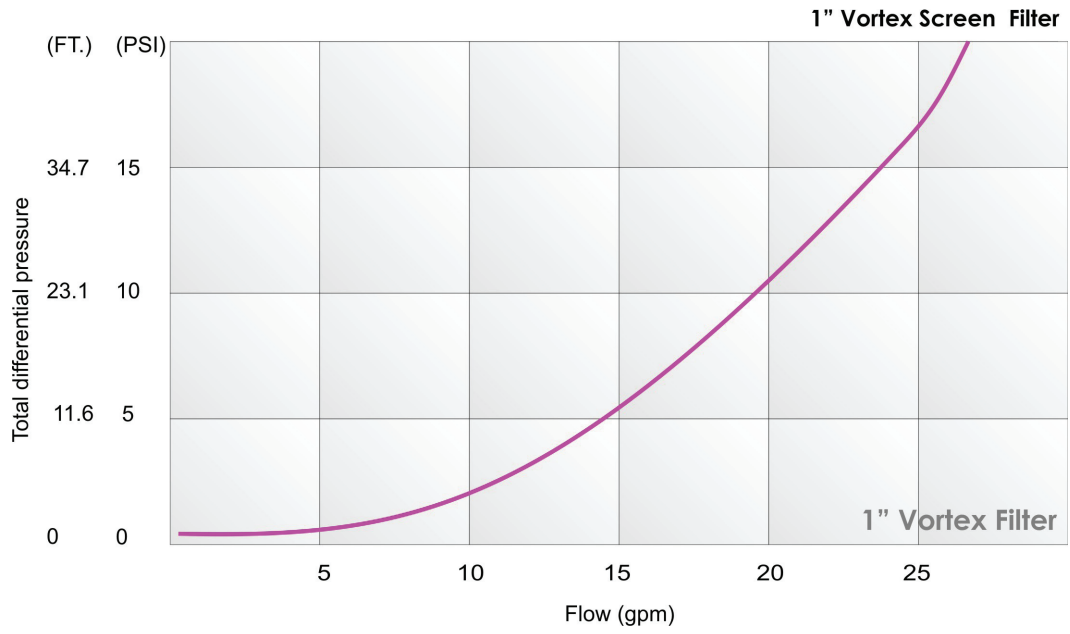

Description

The regulators are preset to regulate pressure in the field. These are recommended with Wasteflow Classic and optional with Wasteflow PC. Under normal operating conditions the pressure in the dripline should be:

10 - 45 psi for Wsteflow Classic and Wasteflow PC

Pressure Regulator Specification

Geoflows pressure regulator shall be designed to handle steady inlet pressures of ___ psi and withstand severe water hammer extremes. It shall handle flow rates between ___ gpm and ___ gpm. Flow restriction shall be negligible until the factory preset pressure is reached. Regulatory accuracy shall be within +/- 6%. Inlet and outlet size shall be 3/4" FIPT. The body shall be constructed of high impact engineering grade thermoplastics. Regulation shall be accomplished by a fixed stainless steel compression spring enclosed in a chamber separate from the normal water passage. Each regulator shall be water tested for accuracy. Pressure regulator shall be Geoflow model number PMR- ____ - _ F



Low, Medium and High Flow Regulator



Extra flow regulator- Flows up to 90 gpm

Item No.	Outlet Pressure	Flow Range	Max. Inlet Pressure	Inlet / Outlet
PMR-20-LF	20 psi	1/8-8 gpm	150 psi / 347ft	3/4" / 3/4" fipt
PMR-20MF	20 psi	2-20 gpm	150 psi / 347ft	1" / 1" fipt
PMR-20-HF	20 psi	10-32 gpm	100 psi / 231ft	1.25" / 1" fipt
PMR-20-XF	20 psi	20-90 gpm	90 psi / 208 ft	3" / 3" ID slip
PMR-30-LF	30 psi	1/8-8 gpm	150 psi / 347 ft	3/4" / 3/4" fipt
PMR-30MF	30 psi	2-20 gpm	150 psi / 347 ft	1" / 1" fipt
PMR-30-HF	30 psi	10-32 gpm	100 psi / 231 ft	1.25" / 1" fipt
PMR-30-XF	30 psi	20-90 gpm	100 psi / 231 ft	3" / 3" ID slip
PMR-40-LF	40 psi	1/8-8 gpm	150 psi / 347 ft	3/4" / 3/4" fipt
PMR-40-MF	40 psi	2-20 gpm	150 psi / 347 ft	1" / 1" fipt
PMR-40-HF	40 psi	10-32 gpm	100 psi / 231 ft	1.25" / 1" fipt
PMR-40-XF	40 psi	20-90 gpm	125 psi / 289 ft	3" / 3"ID slip
PMR-50-MF	50 psi	2-20 gpm	150 psi / 347 ft	1" / 1" fipt
PMR-50-HF	50 psi	10-32 gpm	100 psi / 231 ft	1.25" / 1" fipt
PMR-50-XF	50 psi	20-90 gpm	125 psi / 289 ft	3" / 3" ID slip



LOW FLOW

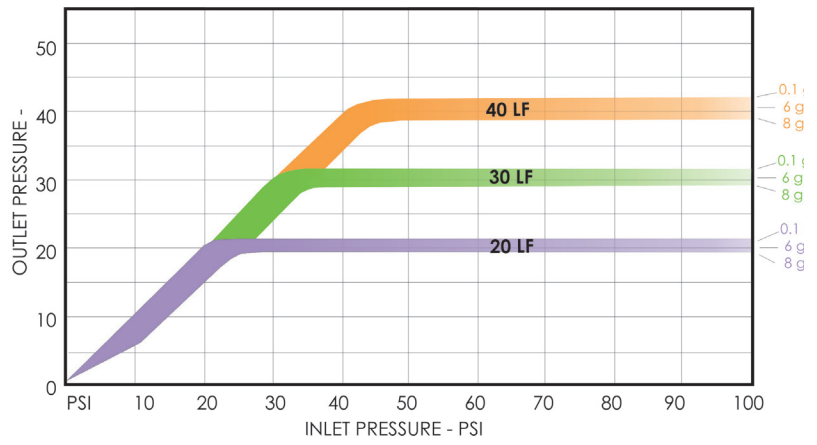

MEDIUM FLOW

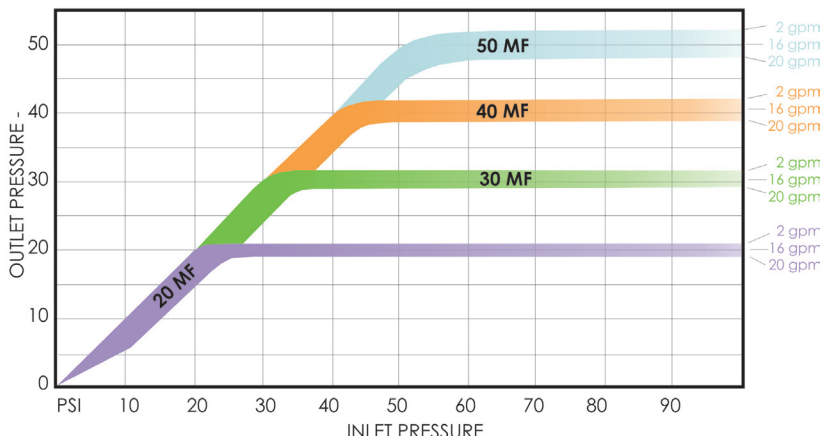

HIGH FLOW

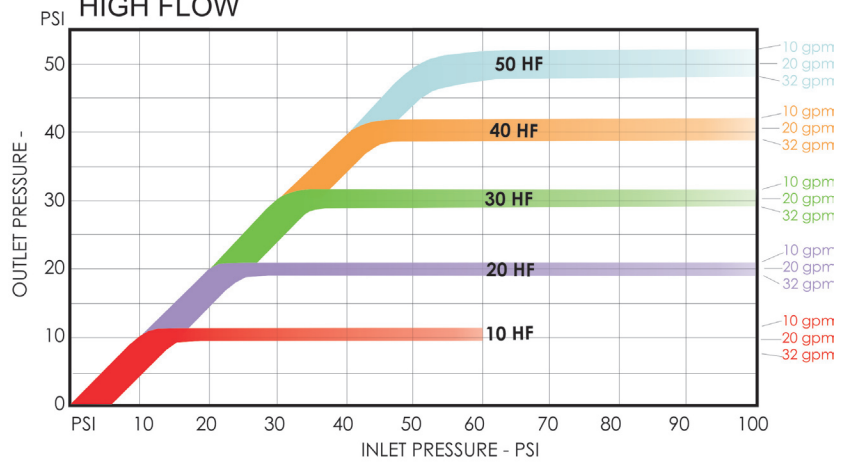

EXTRA FLOW

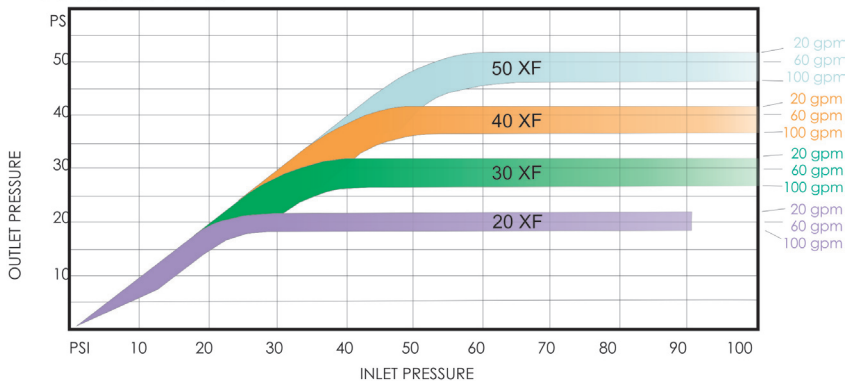

Lockslip Fittings

The lockslip fittings shall be molded of high grade plastic. Wasteflow drip tubing shall be pushed over a barb end, then secured with a locking nut. The fitting shall have the ability to be removed and reapplied with the locking nut. The fitting shall be sized to match Geoflow Wasteflow tube. Standard size is 16mm and standard adapters are 600 series.

Available preassembled on 18" flexible PVC riser (LTFLEXR-18) and flexible PVC loop (LTFLEXL-36).

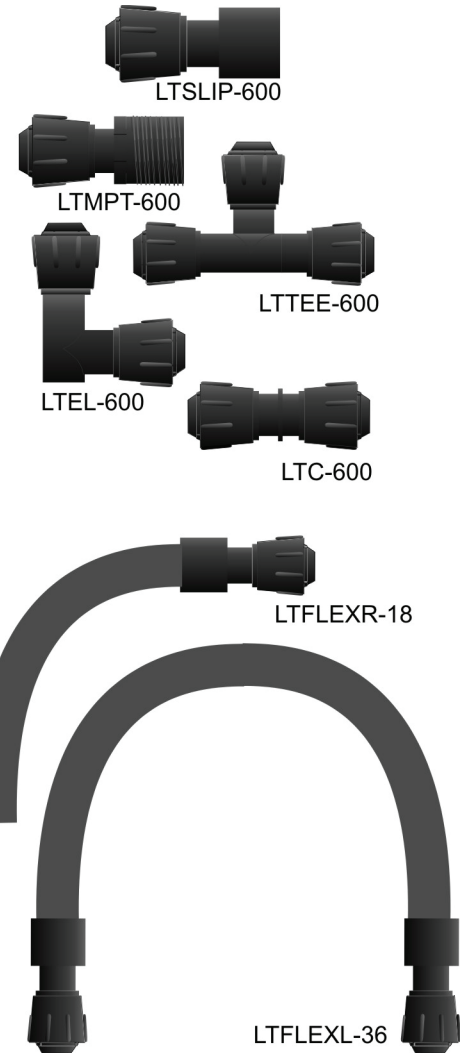

Lockslip Slip Adapters

The slip adapter is used to connect Wasteflow drip tubing to a PVC fitting. The adapter glues into a 3/4" slip fitting. The drip tubing end requires no glue. The lockslip adapter shall be Geoflow part number LTSLIP-600

Lockslip Threaded Adapters

The threaded adapter is used to connect Wasteflow drip tubing to a PVC fitting. The adapter has 3/4" MPT fitting on one side a dripline adapter on the other side. This fitting requires no glue. The lockslip adapter shall be Geoflow part number LTMPT-600

Lockslip Couplings

The coupling is used to connect Wasteflow drip lines together. The adapter glues into a 3/4" slip fitting. This fitting requires no glue. The lockslip coupling shall be Geoflow part number LTC-600

Lockslip Elbows

The elbow is used to connect Wasteflow drip lines or Wasteflow plain tube together in a 90 degree configuration. This fitting requires no glue. The lockslip elbow shall be Geoflow part number LTEL-600

Lockslip Tees

The tee is used to connect Wasteflow drip lines or Wasteflow plain tube together in a tee degree configuration. This fitting requires no glue. The lockslip tee shall be Geoflow part number LTTEE-600

The PVC Glue / Cement:

Saddle to PVC manifold	IPS # 719
Flex PVC to Saddle or Fitting	IPS # 795
If the fitting is made of PVC	IPS # 711
ABS fittings into PVC Fittings (i.e. compression adapters)	IPS # 793

Instructions for solvent welding PVC fittings please visit <http://www.weldon.com/howtovideo>



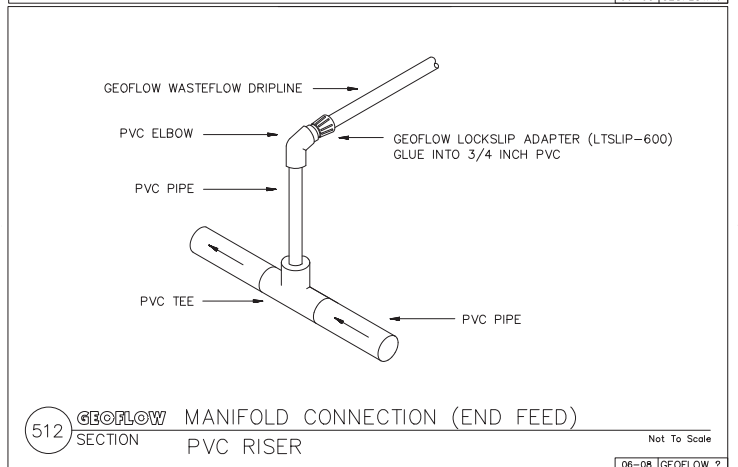
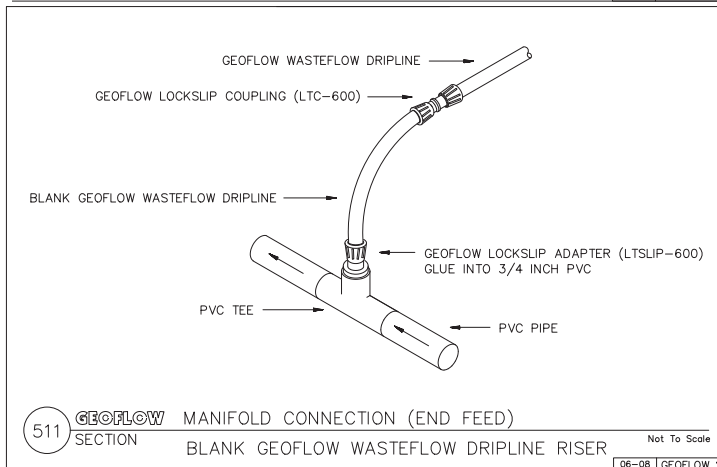
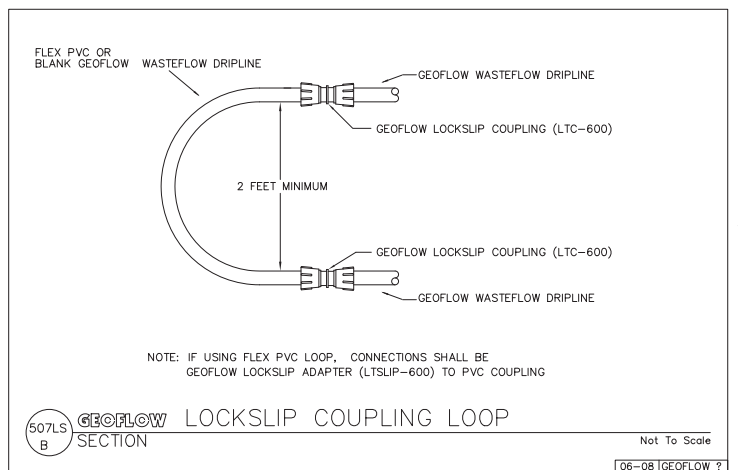
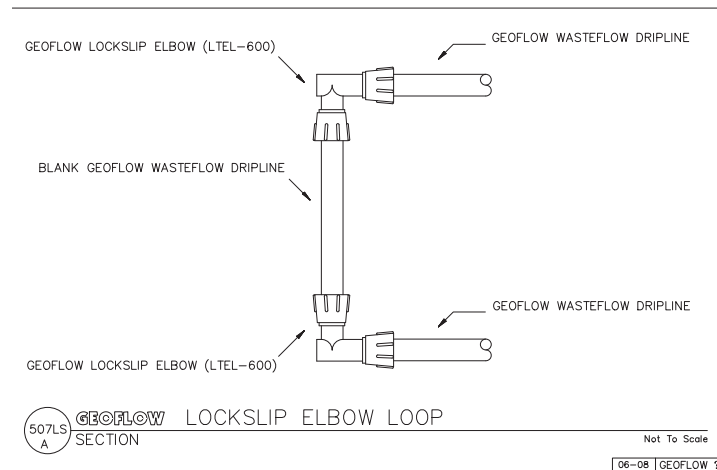
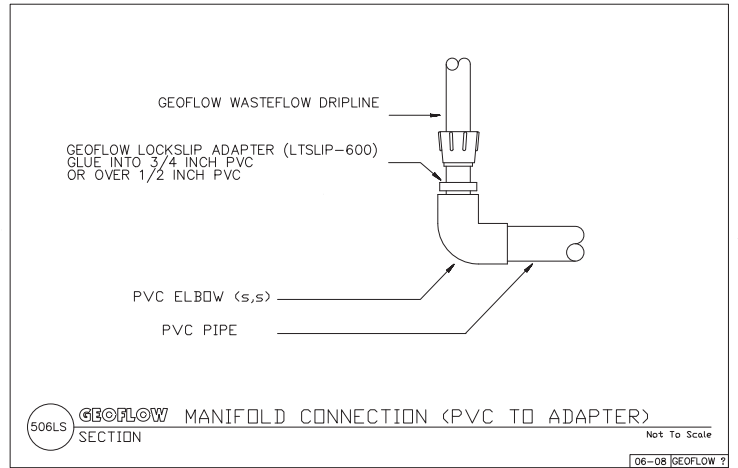
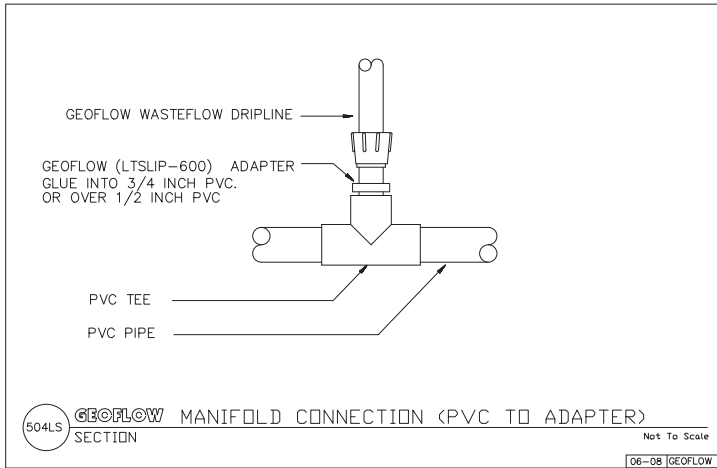
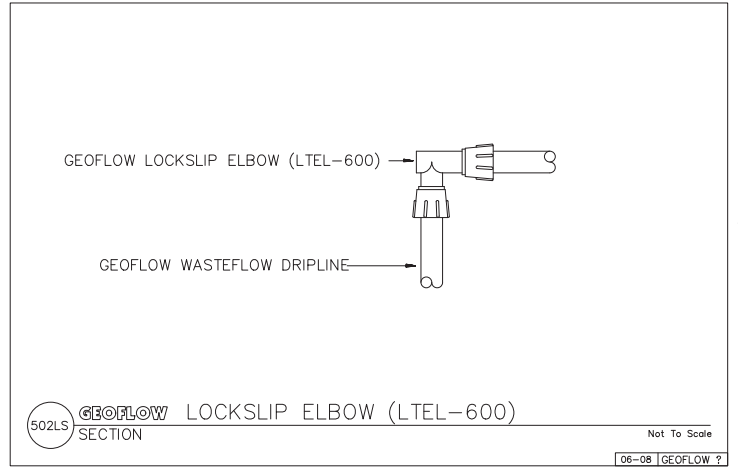
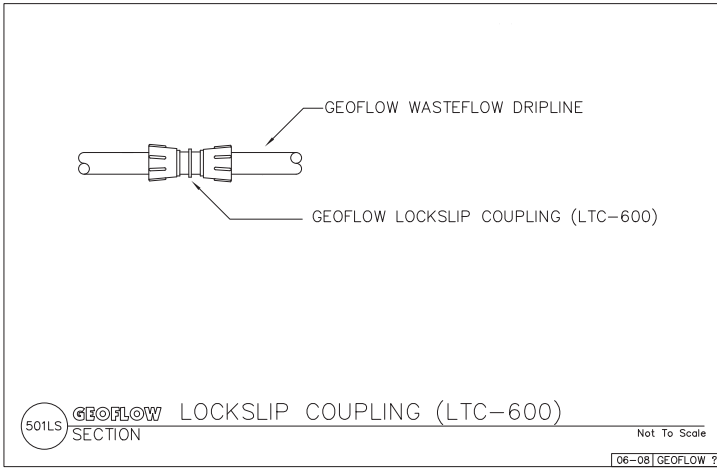

Description

The Ball Check valves prevent backflow or drain down in the system. The true union provides easy access for inline installation and servicing. The true union ball check is designed for quick positive sealing with minimum turbulence, low restriction, and efficient fluid transfer. It can be installed vertically or horizontally. System pressure will unseat the ball, allowing flow. Backflow or head pressure of 30" or 1 to 2 psi will seat the ball and stop backflow. Each check valve ships with female thread and socket adapters. This valve is manufactured 100% from thermoplastic materials, making it less susceptible to corrosion.



Model No.	Inlet/Outlet (FPT or socket)	Length (inches)	Height (inches)	Max Temp (F)	Weight (lbs.)
CV-B-05	0.5"	3.50"	2.00"	140 °	0.75
CV-B-10	1.0"	5.09"	2.31"	140 °	1.1
CV-B-15	1.5"	6.59"	3.81"	140 °	2.2
CV-B-20	2.0"	7.53"	4.22"	140 °	3.0

Specification

All thermoplastic check valves shall be True Union Ball type constructed from PVC Type I Cell Classification 12454. Socket end connections are manufactured to ASTM D2467-94. Threaded connections are manufactured to ASTM D2464-88.

The O-Ring seat shall be Viton®. All valve components shall be replaceable. The check valve shall be pressure rated at 235 psi, non-shock water at 73° F. The ball check valve shall be Geoflow part number CV-B-X.

True Union Ball Check
 Maximum Pressure Rating
 at Given Temperature

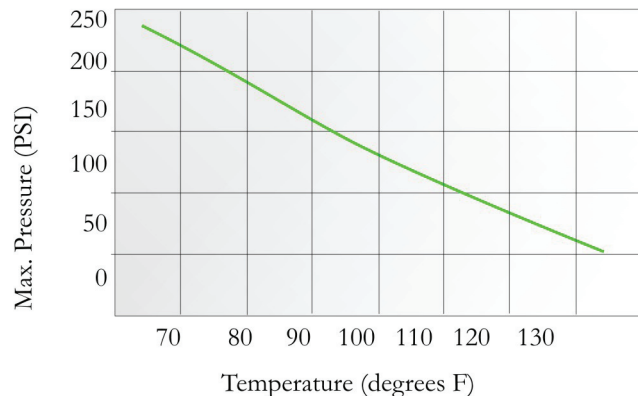

INSTALLATION, OPERATION & MAINTENANCE

- Systems should always be depressurized and drained prior to installing or maintaining your True Union Ball Check Valves.
- Temperature effect on piping systems should always be considered when the systems are initially designed. Piping systems must be designed and supported to prevent excess mechanical loading on valve equipment due to system misalignment, weight, shock, vibration, and the effects of thermal expansion and contraction.
- Because PVC and CPVC plastic products become brittle below 40°F, Geoflow recommends caution in their installation and use below this temperature.
- Due to differential thermal expansion rates between metal and plastic, transmittal of pipe vibration, and pipe loading forces **DIRECT INSTALLATION OF METAL PIPE INTO PLASTIC CONNECTIONS IS NOT RECOMMENDED**. Wherever installation of plastic valves into metal piping systems is necessary, it is recommended that at least 10 pipe diameter in length of plastic pipe be installed upstream and downstream of the plastic valve to compensate for the factors mentioned above.
- **SOCKET CONNECTION:** Socket end connections are manufactured to ASTM D2467 (PVC) and F-439 (CPVC). Solvent cementing of socket end connections to pipe should be performed per ASTM specifications D2855-87. Cut pipe square. Chamfer and deburr pipe. Surfaces must be cleaned and free of moisture, oil, dirt and other foreign material. Remove Union-nuts and end connectors from valve body. Slide Union-nuts, with threads facing valve, onto pipe to which the end connector is to be cemented. Apply primer to inside socket surface of end connector. Never allow primer or cement to contact valve ball or end connector o-ring sealing surfaces, as leaking may result. Use a scrubbing motion. Repeat applications may be necessary to soften the surface of the socket. Next, liberally apply primer to the male end of the pipe to the length of the socket depth. Again apply to the socket, and without delay apply cement to the pipe while the surface is still wet with primer. Next apply cement lightly, but uniformly to the inside of the socket. Apply a second coat of cement to the pipe, and assemble end connector to the pipe, rotating the end connector 1/4 turn in one direction as it is slipped to full depth on to the pipe. The end connector should be held in position for approx. 30 seconds to allow the connection to “set”. After assembly wipe off excess cement. Follow cement manufacturers guidelines for proper “cure-time”, based on the pipe size that you are joining.
- **THREADED CONNECTION:** Threaded end connections are manufactured to ASTM specifications D2464. F437 and ANSI B1.20.1. Due to the variable quality and tolerances of plastic male threaded nipples, Colonial no longer recommends the use of PTFE (Teflon®) tape. We recommend using the following thread sealant: IPS WELD-ON All Seal™. To provide a leak proof joint, the pipe should be threaded into the end connection “hand tight”. A strap wrench may be used to tighten the joint an additional 1/2 turn past hand tight. Tightening beyond this point may induce excessive stress that could cause failure.

Description

Air release occurs when air escape the system at startup and vacuum relief allows air to enter during shutdown. The air vent vacuum breakers are installed at the highest points in the drip field to keep soil from being sucked into the emitters due to back siphoning and back pressure. This is an absolute necessity with underground drip systems. They are also used for proper drainage of the supply and return manifolds. Use one on the high point of the supply manifold and one on the high point of the return manifold and any high points of the system.

Features

Geoflow's new kinetic air vacuum breakers have a twist off cap that is easy to take apart for cleaning. No need to remove the valve to maintain it. The large clear passageway allows lots of air to flow in and out easily. The protected mushroom cap is ideal for wastewater, directing spray downward.

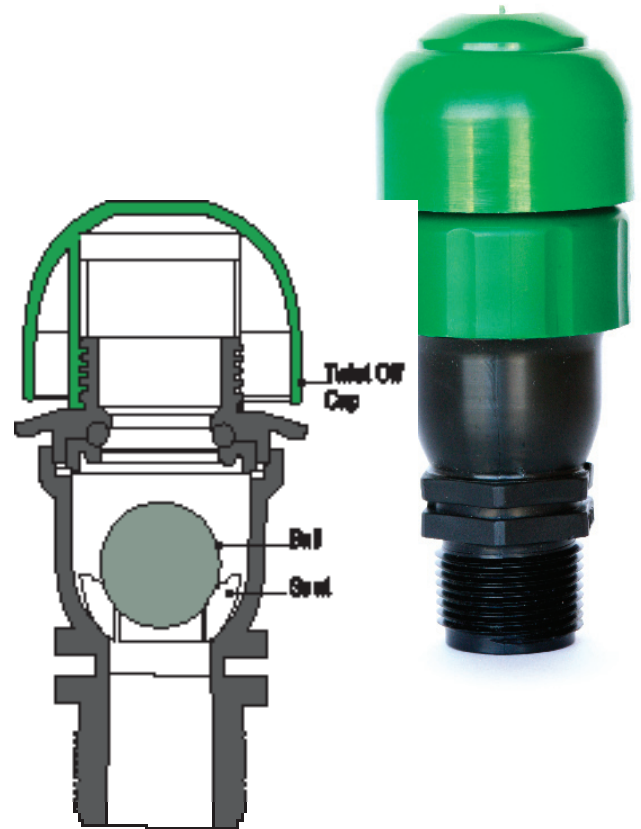

Part No.	APVBK75m	APVBK100m
Inlet	3/4"	1"
Max. Flow Rate	30 gpm	
Max Pressure	80 psi/185 ft.	80 psi/185 ft.
Max Temp	140 oF	140 oF
Height	5"	5.5"
Weight	1 oz.	1.2 oz.

Specification

The Air Vacuum Breaker body and ball shall be made of molded plastic. The ball shall be removable for easy cleaning. The Air Vacuum Breaker shall be part number APVBK75m or APVBK100m as supplied by Geoflow, Inc.

Air and Vacuum Flow Rate

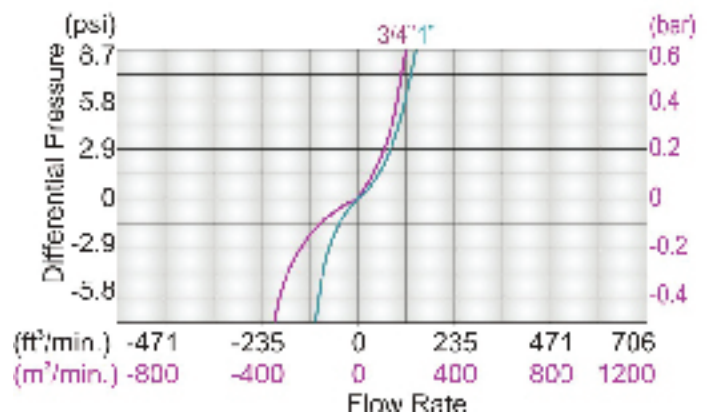

Description

Air release occurs when air escape the system at startup and vacuum relief allows air to enter during shutdown. The air vent vacuum breakers are installed at the highest points in the drip field to keep soil from being sucked into the emitters due to back siphoning and back pressure. This is an absolute necessity with underground drip systems. They are also used for proper drainage of the supply and return manifolds. Use one on the high point of the supply manifold and one on the high point of the return manifold and any high points of the system.

Features

Geoflow's new kinetic air vacuum breakers have a twist off cap that is easy to take apart for cleaning. The large clear passageway allows lots of air to flow in and out easily. The elbow cap design is ideal for directing wastewater spray, directing spray downward. With the ball removed, these airvents can easily be used as a flush port.

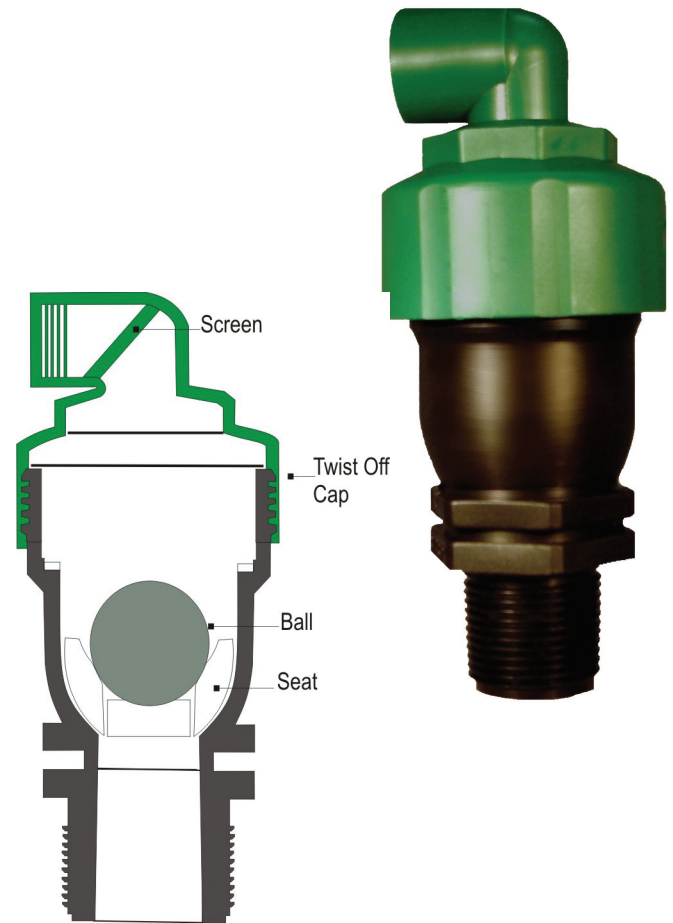

Part No.	APVBK75L	APVBK100L
Inlet	3/4"	1"
Max Pressure	80 psi/185 ft.	80 psi/185 ft.
Max Temp	140 oF	140 oF
Height	5"	5.5"
Weight	1 oz.	1.2 oz.

Available in drip packages or sold separately.

Specification

The Air Vacuum Breaker shall provide instant and continuous vacuum relief and non-continuous air relief. Both the body and the ball shall be made of molded plastic. The ball shall be removable for easy cleaning. The air vacuum breaker shall be part number APVBK75L or APVBK100L as supplied by Geoflow, Inc.

Air and Vacuum Flow Rate

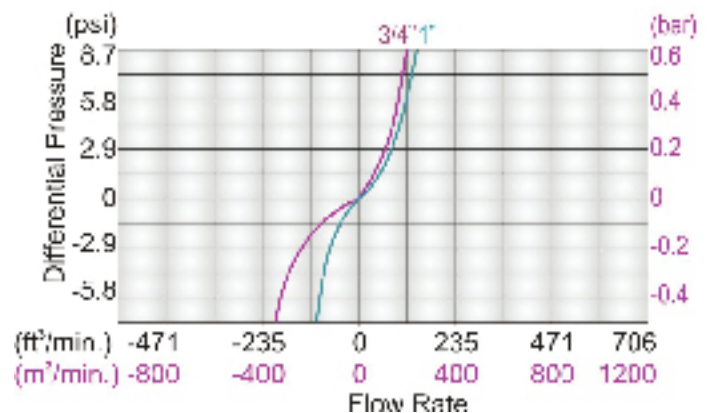

Description

The Solenoid Valve is used to flush field and filters and as zone valves. It is electrically operated. It is normally closed, and in the event of a power failure the valve will close.

Geoflow's automatic water control valves are designed for vertical or horizontal installation. The Wye 'Y' valve body design includes a full bore seat with unobstructed flow path, free of any in-line ribs, supporting cage, or shafts. Its unitized Flexible Super Travel (FST) diaphragm and guided plug provide a significantly 'look through' passage from end to end resulting in ultra-high flow capacity with minimal pressure loss.

The combination of a long travel guided valve plug, peripherally supported diaphragm, and replaceable valve seal provides:

- No chattering or slamming closed
- Accurate and stable regulation with smooth motion
- Low operating pressure requirements
- No diaphragm erosion and distortion
- Chemical resistant

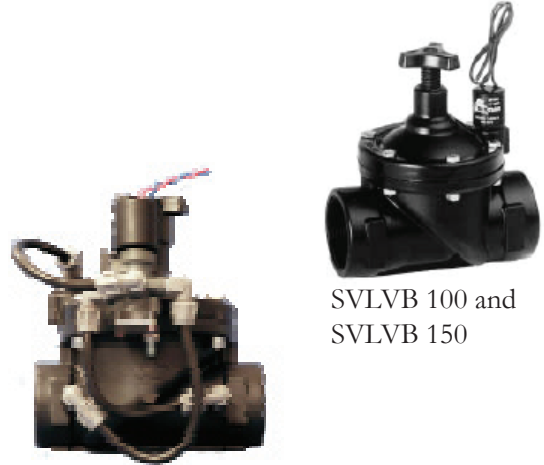

SVLVB200 and
SVLVB300

SVLVB100 and
SVLVB150

	SVLVB-100	SVLVB 150	SVLVB 200	SVLVB 300
Inlet/Outlet Size (FNPT)	1"	1.5"	2"	3"
Length (L)	4.3"	6.3"	9.0"	12.2"
Height (H)	4.5"	7.2"	7.4"	11.0"
Width (W)	3.0"	5.0"	5.4"	
R	7/8"	1-3/8"	1-5/8"	4.0"
Weight	12.5 oz	2.2 lbs.	2.97 lbs.	8.8 lbs
Valve pattern	Globe	Globe	Wye 'Y'	Wye 'Y'
Operating range	10 - 150 psi	10 - 150 psi	7 - 140 psi	7 - 140 psi
Max pressure	180 deg F	180 deg F	180 deg F	180 deg F
Materials				
Body & cover	Nylon reinforced	Nylon reinforced	Glass filled nylon	Glass filled nylon
Metal parts	Stainless steel	Stainless steel	Stainless steel	Stainless steel
Diaphragm	Natural rubber	Natural rubber	NBR (Buna-N), nylon reinforced fabric	NBR (Buna-N), nylon reinforced fabric
Seals	NBR & NR	NBR & NR	NBR (Buna-N)	NBR (Buna-N)

On/Off Modes

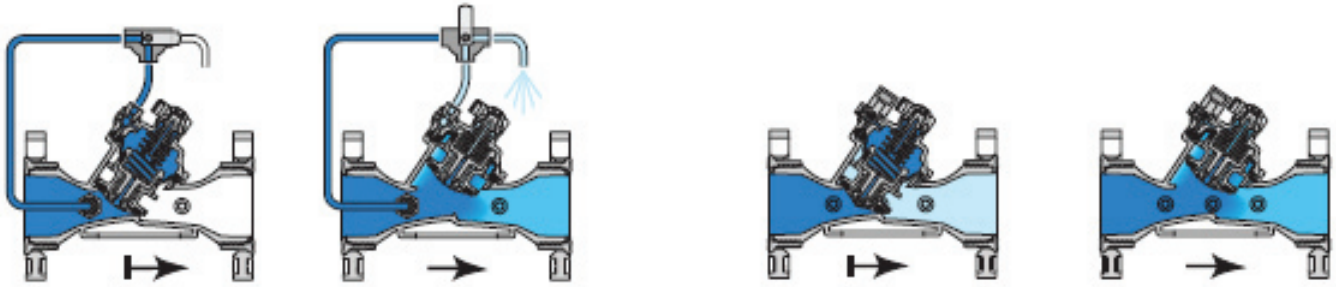

3-Way Control

Line pressure applied to the control chamber of the valve creates a hydraulic force that moves the valve to the closed position and provides drip tight sealing. Discharging pressure from the control chamber to the atmosphere causes the line pressure under the plug to open the valve.

2-Way Internal Control

Line pressure enters the control chamber through the internal restriction. The closed solenoid causes pressure to accumulate in the control chamber, thereby shutting the valve. Opening the Solenoid releases more flow from the control chamber than the restriction can allow in. This causes pressure in the control chamber to drop, allowing the valve to open.

Installation

The manual bleed lever should always be in the VERTICAL position and the dial on top should be free spinning. Clockwise rotation closes valve.

Pressure Loss through valves (in psi)

Recommended minimum pressure differential: 7 psi

Electrical data:

Wiring requires a single lead from the controller to each solenoid valve, plus a common neutral to all solenoids. Type UF wire, UL listed, is recommended for all hookups.

Standard 24V ACV (50-60Hz)

Current Holding 0.24A 5.76 VA

Current Inrush 0.46A 11.04VA

Maximum allowable loss 4.8 Volts for the 24V AC system

Contact Geoflow for optional voltages or larger valves

Maximum Length of wire run – Controller to Valve

# Wire	Resistance Ohm / 1000'	Maximum Run
#18	6.39	800 Ft.
#16	4.02	1,275 Ft.
#14	2.58	2,000 Ft.
#12	1.62	3,200 Ft.
#10	1.02	5,100 Ft.
#8	0.641	8,000 Ft.
#6	0.403	12,750 Ft.
#4	0.253	20,500 Ft.
#2	0.158	32,500 Ft.

Maximum Voltage loss with a valve with a three way Solenoid is 4.8 Volts

[1] Cover Ring

The cover ring fastens valve cover to body, stiffening and strengthening the valve body, enabling simple maintenance. A cover ring key is available.

[2] Pilot Adaptor

The pilot adaptor allows us to connect the mini-pilot valve or the Galit hydraulic relay to the valve body.

[3] Valve Cover

The cover's strong construction meets rough service conditions. Optional cover types (3"; DN80 and smaller valves) are capable of accepting a Flow Stem, a Flow Stem + Position Indicator, and a 2-Way Solenoid (2W-N1 Electric Type).

[4] Auxiliary Closing Spring

One single high grade stainless steel spring provides a wide operation range, ensuring low opening pressure and secured closing.

[5] Plug Assembly

The unitized Flexible Super Travel (FST) plug assembly combines a long travel guided valve plug, peripherally supported diaphragm, and replaceable diaphragm and valve seal. The diaphragm fully meets the valve's operating pressure range requirements.

[5.1] Diaphragm Holder

[5.2] Diaphragm

[5.3] Plug

[5.4] Plug Seal

[6] hYflow 'Y' Valve Body

Glass-filled nylon construction meets rough service conditions with high chemical and cavitation resistance.

End-to-end "look-through" design and full bore seat with unobstructed flow path, free of any in-line ribs, supporting cage, or shafts, enables ultra-high flow capacity with minimal pressure loss.

[7] End Connections

Adaptable on-site to a wide range of end connection types and sizes:

[7.1] Flanges: Plastic or metal "Corona" with elongated slots enable meeting diverse flange standards ISO, ANSI and JIS.

[7.2] Flange adaptor external thread

[7.3] Internal threads

[8] Flange Adapter

Articulated flange connections isolate the valve from line bending and pressure stresses.

[9] Valve Legs

Stabilize the valve and serve also as mounting brackets.



PVC 40 FRICTION LOSS CHART

	1/2"		3/4"		1"		1 1/4"		1 1/2"	
Flow GPM	Velocity FPS	Pressure Drop PSI	Velocity FPS	Pressure Drop PSI	Velocity FPS	Pressure Drop PSI	Velocity FPS	Pressure Drop PSI	Velocity FPS	Pressure Drop PSI
1	1.05	0.43	0.60	0.11	0.37	0.03				
2	2.11	1.55	1.2	0.39	0.74	0.12	0.43	0.03		
3	3.17	3.27	1.8	0.83	1.11	0.26	0.64	0.07	0.47	0.03
4	4.22	5.57	2.41	1.42	1.48	0.44	0.86	0.11	0.63	0.05
5	5.28	8.42	3.01	2.15	1.86	0.66	1.07	0.17	0.79	0.08
6	6.33	11.81	3.61	3.01	2.23	0.93	1.29	0.24	0.95	0.11
8	8.44	20.10	4.81	5.12	2.97	1.58	1.72	0.42	1.26	0.20
10	10.55	30.37	6.02	7.73	3.71	2.39	2.15	0.63	1.58	0.30
15			9.02	16.37	5.57	5.06	3.22	1.33	2.36	0.63
20					7.42	8.61	4.29	2.27	3.15	1.07
25					9.28	13.01	5.36	3.42	3.94	1.63
30					11.14	18.22	6.43	4.80	4.73	2.27
35							7.51	6.38	5.52	3.01
40							8.58	8.17	6.30	3.88
45							9.65	10.16	7.09	4.80
50							10.72	12.35	7.88	5.83
60									9.46	8.17
70									11.03	10.87
	2" pipe		2 1/2" pipe		3" pipe		4" pipe		6" pipe	
Flow GPM	Velocity FPS	Pressure Drop PSI	Velocity FPS	Pressure Drop PSI	Velocity FPS	Pressure Drop PSI	Velocity FPS	Pressure Drop PSI	Velocity FPS	Pressure Drop PSI
6	0.57	0.03								
8	0.76	0.06	0.54	0.02						
10	0.96	0.09	0.67	0.04						
15	1.43	0.19	1.01	0.08	0.65	0.03				
20	1.91	0.32	1.34	0.13	0.87	0.05				
25	2.39	0.48	1.67	0.20	1.08	0.07				
30	2.87	0.67	2.01	0.28	1.30	0.10				
35	3.35	0.89	2.35	0.38	1.52	0.13	0.88	0.03		
40	3.82	1.14	2.64	0.48	1.73	0.17	1.01	0.04		
45	4.30	1.42	3.01	0.60	1.95	0.21	1.13	0.05		
50	4.78	1.73	3.35	0.73	2.17	0.25	1.26	0.07		
60	5.74	2.42	4.02	1.02	2.60	0.35	1.51	0.09		
70	6.69	3.22	4.69	1.36	3.04	0.47	1.76	0.12		
80	7.65	4.13	5.36	1.74	3.47	0.60	2.02	0.16		
90	8.60	5.13	6.03	2.16	3.91	0.75	2.27	0.20		
100	9.56	6.23	6.70	2.63	4.34	0.91	2.52	0.24	1.11	0.03
125	11.95	9.42	8.38	3.97	5.42	1.38	3.15	0.37	1.39	0.05
150			10.05	5.56	6.51	1.93	3.78	0.51	1.67	0.07
175					7.59	2.57	4.41	0.68	1.94	0.09
200					8.68	3.40	5.04	0.90	2.22	0.12