



STARTER CONTROL MODULE S.W. Version 7.006

Installation & Operation Manual

IPS|IPS-RV

INTELLIGENT PUMP STARTER AND SOFT STARTER

SAFETY PRECAUTIONS

To prevent injury and property damage, follow these instructions. Failure to adhere to installation/operation procedures and all applicable codes may result in hazards as indicated by warning codes below:

DANGER

Indicates an imminently hazardous situation which, if not avoided, will result in death or serious injury. This signal word is to be limited to the most extreme situations.

WARNING

Indicates a potentially hazardous situation which, if not avoided, could result in death or serious injury.

CAUTION

Indicates a potentially hazardous situation which, if not avoided, may result in minor or moderate injury. It may also be used to alert against unsafe practices.



This is the safety alert symbol. Read and follow instructions carefully to avoid a dangerous situation.



This symbol alerts the user to the presence of “dangerous voltage” inside the product that might cause harm or electrical shock.

CAUTION

As with all electrical products, read manual thoroughly. Only qualified, expert personnel should perform maintenance and installation. Contact the nearest authorized service facility for examination, repair, or adjustment. Do not disassemble or repair unit unless described in this manual; death or injury to electrical shock or fire hazard may result. Specifications and manual data are subject to change. Consult factory for additional information.

DANGER

Equipment can start automatically. Lockout/tagout before servicing

Table of Contents

1. Introduction	3
2. Specifications	5
• Motor Protection	5
• Soft Starter (IPS-RV) Features	5
• SCM Meter Base	6
• Control Terminals	7
• IPS Control Terminals	7
• IPS-RV Control Terminals	8
3. Installation / Wiring	9
• Torque Specifications	9
• IPS Wiring Diagrams	10
• IPS-RV Wiring Diagram	12
4. Operation	14
• Control	14
• Lockout Feature / Advanced Settings Lockout	15
• Setting Adjustments	16
• Advanced Settings Menu Structure	17
• Display Features	23
• Fault and Alarm Descriptions	25



Appendix

A. Overload and Ground Fault Trip Curves	28
• Overload Trip Curves	28
• Ground Fault Trip Curve	29
B. Ground Fault Test Procedure	30
C. Option Boards	31
• Ethernet I/O (Fault Logging)	31
• Tru-Power™ (Power Meter)	32
• Modbus RTU	33
D. Warranty Information	35

1. Introduction

Overview

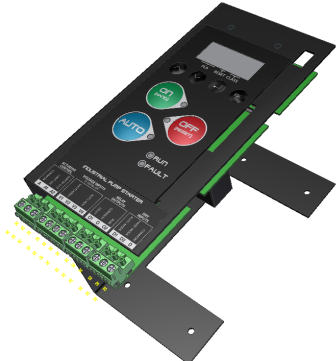
The Franklin Control Systems Starter Control Module (SCM) consists of a customer interface board assembly in combination with a meter base, which provides 1 or 3 phase AC motor control, motor protection, and power metering. The SCM provides motor control and protection for the Franklin Control Systems IPS and IPS-RV series starters.

SCM Customer Interface Assembly	SCM Meter Base
 The image shows the SCM Customer Interface Assembly, a black printed circuit board (PCB) with a green terminal block at the bottom. It features three push buttons: a green 'ON' button, a blue 'AUTO' button, and a red 'STOP' button. A small digital display is located at the top. The board is mounted on a metal base plate with mounting holes.	 The image shows the SCM Meter Base, a black, rectangular metal component. It has a curved top and a base with mounting feet. The front face has some internal components visible through a cutout.

Soft starters, such as the IPS-RV, are designed to reduce the voltage and subsequently the inrush current during motor starting. The lower inrush current lessens the torque generated by the motor during startup, which reduces wear on mechanical parts and improves system lifetime. Some utilities and localities require that a method of reduced voltage starting be used on motors over a given horsepower to reduce demand fluctuations and peak current draw.

General AC motor starting that require across-the-line or reduced voltage is provided by the SCM based IPS starter or IPS-RV soft starter. The IPS-RV provides soft starting functionality by using silicon controlled rectifiers (SCRs) to limit voltage. The IPS-RV includes the standard features IPS across-the-line starter.

Features for both the IPS and IPS-RV are defaulted for operation with submersible motors. For surface motor applications, defaults can be pre-set from the factory. Otherwise, motor protection or soft starter settings may need to be adjusted.

Overview Continued

Additional optional circuit boards may be added to IPS series starters (Excludes IPS-RV). Features include:

- 1) Power Metering Option Board
 - Provides energy metering on both a kWh pulse output and a 4-20mA analog kW measurement output terminal.
- 2) Modbus RTU Communications Option Board (Standard on IPS-RV)
 - Provides Modbus RTU Communications support. Also provides two dry contact digital inputs with float switch control provisions. Also provides an analog input, configurable to support 4-20mA, 0-10V, and 10K Thermistor input signals.
- 3) Ethernet Fault Logging Option Board
 - Provides data/fault logging, date and time stamped with operating conditions for up to 100 events.

*For detailed descriptions of IPS option boards, see Appendix C

Applications

- IPS: Across-the-line starter for surface mount and submersible motors and pumps
- IPS-RV: Soft starter for surface mount and submersible motors and pumps

Features

- LCD Energy Display - kW, kVA, kVAR, kWh
- Power Monitoring
- Motor Protection
- Motor Control - HOA switch
- Combination versions feature a molded case circuit breaker, suitable for use as a service disconnect

Motor Protection Overview		
Protection	IPS	IPS-RV
Electronic Overload	Yes	Yes
Overload Trip Class	5-30	5-30
Phase Unbalance	Yes	Yes
Phase Loss	Yes	Yes
Reverse Phase	Yes	Yes
Cycle Fault	Yes	Yes
Locked Rotor	Yes	Yes
Ground Fault	Yes	Yes
Under Power	Yes	Yes
Over Power	Yes	Yes
Out of Calibration	Yes	N/A
Max Time to Start	Yes	N/A
Over/Under Voltage	Yes	Yes
Backspin Delay	Yes	Yes
On Delay	Yes	Yes
Warm Start Provision	Yes	Yes
Cool Down Profile	Yes	Yes
Automatic/Manual Reset	Yes	Yes
Runtime Delay	Yes	Yes
Off Delay	Yes	Yes

2) Specifications

Motor Protection Descriptions

Feature	Description
Overload	Selectable Class 5-30, trips within inverse trip curve (see Appendix A)
Ground Fault	UL 1053 ground fault protection (see Appendix A for trip curves, Appendix B for test procedure)
Locked Rotor	Trips within 0.5 seconds upon locked rotor detection
Cycle Fault	Trips when motor starting rate exceeds 20 starts/minute
Out of Calibration	Trips in 10 seconds if measured inrush current is less than 400% or greater than 1400% of FLA setting.
Max. Time to Start	Trips after 10 seconds if current is still above 200% of FLA and decreasing.
Under Power (Dry-run)	Trips if the measured electrical input falls below selectable level (1-99%)
Over Power	Trips if the measured electrical input rises above selectable level (101-200%)
Over / Under Voltage	Trips if the measure voltage is above or below the selectable level ($\pm 5\%$ -25%)
Voltage Phase Unbalance	Trips when the percentage of deviation between any one phase and the average voltage is greater than the selected % level. (1%-50%)
Voltage Reverse Phase	Trips if voltage phases are reversed from expected A-B-C ordering
Current Phase Unbalance	Trips when the percentage of deviation between any one phase and the average current is greater than the selected % level. (1%-50%)

Default Settings

IPS and IPS-RV starters are defaulted to protect submersible motor applications. For surface motor applications, adjustments to under power parameters may need to be adjusted.

Feature	IPS	IPS-RV
Overload	Class 10	Class 10
Service Factor	1.15	1.15
Ground Fault	*On / 1A	*On / 1A
Locked Rotor	On	On
Cycle Fault	On	On
Out of Calibration	On	NA
Max. Time to Start	On	NA
Under Power (Dry-run)	On / 60%	On / 60%
Over / Under Voltage	On / 15%	On / 15%
Voltage Phase Unbalance	On / 3%	On / 3%
Voltage Reverse Phase	On	On
Current Phase Unbalance	On / 5%	On / 5%

*Ground fault protection not available on models with current ranges above 95A

Operational

The IPS-RV is rated for 6 starts per hour @:

7 seconds max start time @ 500% FLA

20 seconds max start time @ 400% FLA

30 seconds max start time @ 300% FLA

Meter Base Layout and Terminal Descriptions

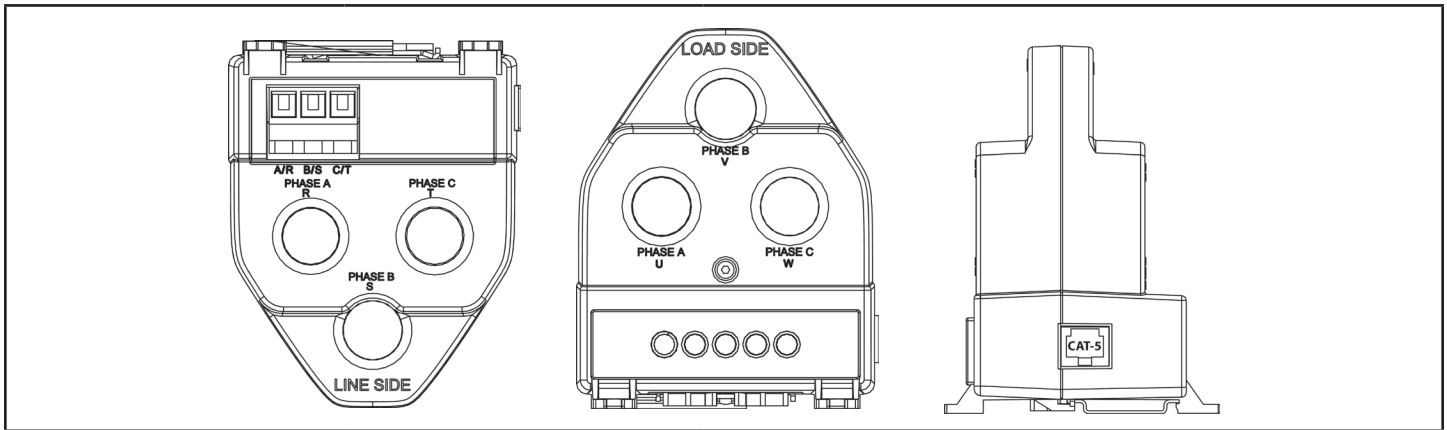

Name	Type	Description	Details
A/R	Terminal	Phase A voltage taken from line side or contactor	Max 600VAC, 24-10 AWG wire
B/S	Terminal	Phase B voltage taken from line side or contactor	Max 600VAC, 24-10 AWG wire
C/T	Terminal	Phase B voltage taken from line side or contactor	Max 600VAC, 24-10 AWG wire
CAT-5	CAT-5	Connection to SCM control board	Non-crossover CAT-5 cable only. Connect to SCM Customer Interface Board only.
PHASE A	Tunnel	Current measurement on Phase A	Max 1/0 AWG. Feed phase A load wire through tunnel and connect to contactor. Ensure "LOAD SIDE" faces motor and "LINE SIDE" faces contactor terminals.
PHASE B	Tunnel	Current measurement on Phase B	Max 1/0 AWG. Feed phase B load wire through tunnel and connect to contactor. Ensure "LOAD SIDE" faces motor and "LINE SIDE" faces contactor terminals.
PHASE C	Tunnel	Current measurement on Phase C	Max 1/0 AWG. Feed phase C load wire through tunnel and connect to contactor. Ensure "LOAD SIDE" faces motor and "LINE SIDE" faces contactor terminals.

SCM Main Circuit Board Terminal Descriptions

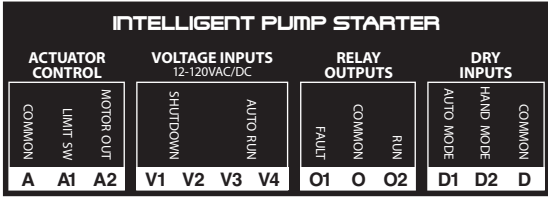
IPS Control Terminals		
 <p style="text-align: center;">INTELLIGENT PUMP STARTER</p> <p style="text-align: center;"> ACTUATOR CONTROL VOLTAGE INPUTS 12-120VAC/DC RELAY OUTPUTS DRY INPUTS COMMON LIMIT SW MOTOR OUT SHUTDOWN AUTO RUN FAULT COMMON RUN AUTO MODE HAND MODE COMMON A A1 A2 V1 V2 V3 V4 O1 O O2 D1 D2 D </p>		
Symbol	Name	Description
<u>Actuator</u> - Motor output supplies same voltage as control power input. 120VAC for actuator motor. Normally open dry contact or transistorized input for actuator limit switch input.		
A	Common	Common terminal for actuator motor and actuator limit input.
A1	Limit Switch Input (NO)	When active (closed), the actuator is in position.
A2	Motor Output (NO)	Provides voltage to the actuator motor when the starter commands the (primary) motor to start. The primary motor will be disabled until the actuator is in position.
<u>Voltage Inputs</u> - Apply 10-120VAC/DC, 10mA Max to energize		
V1-V2	Shut Down	When active (energized), the starter will stop the motor in all modes. When not used, shutdown must be disabled from the display. (Located in the Advanced Settings Menu under Edit Control Inputs)
V3-V4	Auto Run	When active (energized), the starter will start the motor in Auto Mode.
<u>Relay Outputs</u> - Relay contacts rated for: 0.3A @ 125VAC, 1A @ 24VDC		
O1	Fault (NO)	When active (closed), a fault has occurred and the starter is no longer running.
O	Common	Common terminal for Fault and Run Output.
O2	Run (NO)	When active (closed), the motor is running and there is proof of flow.
<u>Dry Inputs</u> -		
D1	Auto Mode	By default, the dry inputs are factory wired to door mounted pilot devices.
D2	Hand Mode	
D	Common	

IPS Power Connections (Factory wired)		
PWR	Control Power Input	120VAC
COIL	Contactor Coil Output	Supplies same voltage as control power input.
CAT-5	CAT-5 Connection	Non-crossover CAT-5 cable only. Connect to SCM Meter Base only.

SCM Main Circuit Board Terminal Descriptions

IPS-RV Control Terminals		
Symbol	Name	Description
<u>Voltage Inputs</u> - Apply 10-120VAC/DC, 10mA Max to energize		
V1-V2	Shut Down	When active (energized), the starter will stop the motor in all modes. When not used, shutdown must be disabled from the display. (Located in the Advanced Settings Menu under Edit Control Inputs)
V3-V4	Auto Run	When active (energized), the starter will start the motor in Auto Mode.
<u>Relay Outputs</u> - Relay contacts rated for: 0.3A @ 125VAC, 1A @ 24VDC		
O1	Fault (NO)	When active (closed), a fault has occurred and the starter is no longer running.
O	Common	Common terminal for Fault and Run Output.
O2	Run (NO)	When active (closed), the motor is running and there is proof of flow.
<u>Dry Inputs</u> -		
D1	Auto Mode	By default, the dry inputs are factory wired to door mounted pilot devices.
D2	Hand Mode	
D	Common	
Soft Starter Gate Drive Connection - RJ45 connector		
Gate Drive Board	Cat-5 Connection	Factory Wired. Non-crossover cat-5 cable only. Connect to gate drive board only. Do not connect to other devices.
RS-485 Connection - Isolated RS-485 serial communications, 5VDC		
+	RS-485 Positive Wire	Provides RS-485 connection for Modbus RTU communications.
-	RS-485 Negative Wire	
S	RS-485 Shield Wire	
Programmable Dry Inputs (Smart Float Switch Provisions) - Contacts or transistorized inputs		
D	Common	See pg. 32-33 for operation instructions. If float switches are disabled, D3 defaults to a NO/NC dry auto input.
D3	Lower Float Switch (NO/NC)	
D4	Upper Float Switch (NO/NC)	
Analog Input - Selectable analog inputs (4-20mA, 0-10V, or 10k Ω thermistor)		
A-	Analog Negative	Negative terminal (analog viewable view Modbus).
A+	Analog Positive	Positive terminal (analog viewable view Modbus).
Jumper	Not Shown	Selects analog option. See diagram on circuit board.
Termination Resistance - DPDT switch		
Term. Res.	ON/OFF	Switch position indicates if 120 Ω termination resistors and 745 Ohm line bias resistors for RS-485 connections are on or off.

IPS-RV Power Connections (Factory wired)		
PWR	Control Power Input	120VAC
COIL	Contacting Coil Output	Supplies same voltage as control power input
CAT-5	CAT-5 Connection	Non-crossover CAT-5 cable only. Connect to SCM Meter Base only.

3) Installation/Wiring



DANGER

HAZARDOUS VOLTAGE

- Disconnect and lock out all power before installing or servicing equipment.
- This equipment may require locking out multiple power sources prior to service
- Install and wire in accordance with all applicable local & national electrical and construction codes

FAILURE TO FOLLOW THESE INSTRUCTIONS MAY RESULT IN DEATH OR SERIOUS INJURY

Mounting

Mount the starter on a vertical surface, with the line terminals facing up.



WARNING

- To maintain overcurrent, short-circuit, and ground-fault protection, the manufacturer's instructions for selecting current elements and setting the instantaneous-trip circuit breaker must be followed.
- Tripping of the instantaneous-trip circuit breaker is an indication that a fault current has been interrupted. Current-carrying components of the magnetic motor controller should be examined and replaced if damaged to reduce the risk of fire or electric shock.
- Do not locate starter in an environment subject to flammable gases, dusts or materials. Contact arcing can induce explosion or fire.
- Locate starter in a location appropriate to enclosure ratings and operational ratings.
- Do not allow any metal shavings or debris from installation to enter enclosure.

Wiring

Wire main power input and motor leads to the appropriate terminals tightened to specified torques indicated in the Torque Table. Use only copper conductors rated at least 60°C for applications less than 100A and at least 75°C ≥ 100A. Maintain proper clearances and verify that no possibility of an electrical short exists between the power conductors or enclosure. Ensure that wires are not under stress and all insulation is intact. Verify voltage input matches label and the control power is tapped per schematic.

Terminal Torque Specifications

Low Voltage Wiring

Automation system control wiring should be run in a separate conduit.

The control terminals accept 26~14AWG wire torqued to 3.5 in-lb.

Power Wiring Torque Table (lb-in)						
NEMA Size	IPS			IPS-RV		
	Input		Output	Input		Output
	MCCB Disconnect	No Disconnect		MCCB Disconnect	No Disconnect	
	L1-L2-L3	L1-L2-L3	T1-T2-T3	L1-L2-L3	L1-L2-L3	T1-T2-T3
1	60	10.6	35	60	10.6	35
2	90	10.6	35	90	10.6	35
3	150	61	35	150	61	35
3+	325	61	35	325	61	35
4	375	49.5	87	375	49.5	49.5
5	375	88	200	375	88	200
5+	375	88	200	N/A	N/A	N/A

IPS Wiring Schematic (S1~S3P)

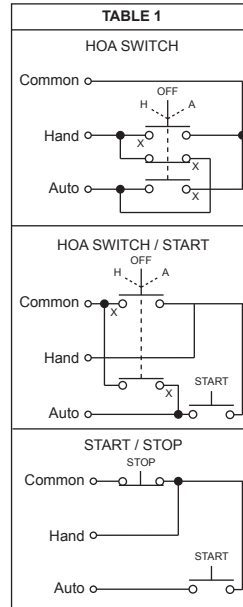
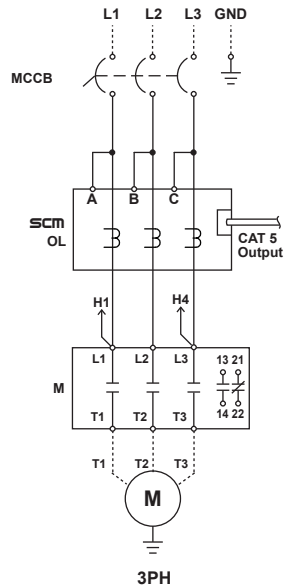
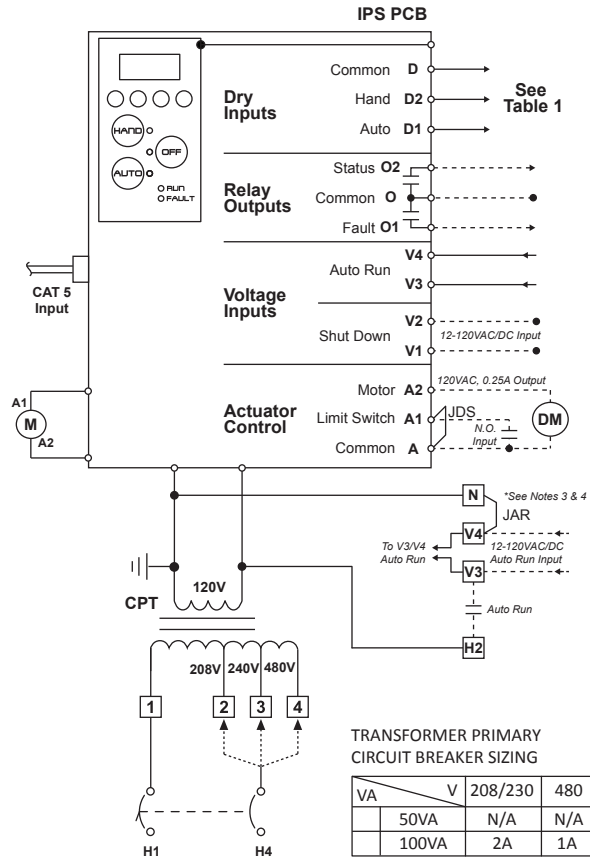

- NOTES:**
1. DASHED LINES INDICATE FIELD WIRING
 2. REMOVE JUMPER JDS TO WIRE LIMIT SWITCH
 3. WHEN JUMPER JAR IS PRESENT, TERMINALS V3 & H2 ACT AS CONNECTIONS FOR A NORMALLY OPEN, DRY CONTACT, AUTO RUN INPUT.
 4. REMOVE JUMPER JAR TO USE V3 & V4 TERMINALS AS A VOLTAGE, AUTO RUN INPUT. APPLY 12-120VAC/DC TO ENERGIZE

IPS Wiring Schematic (S4~S5P)

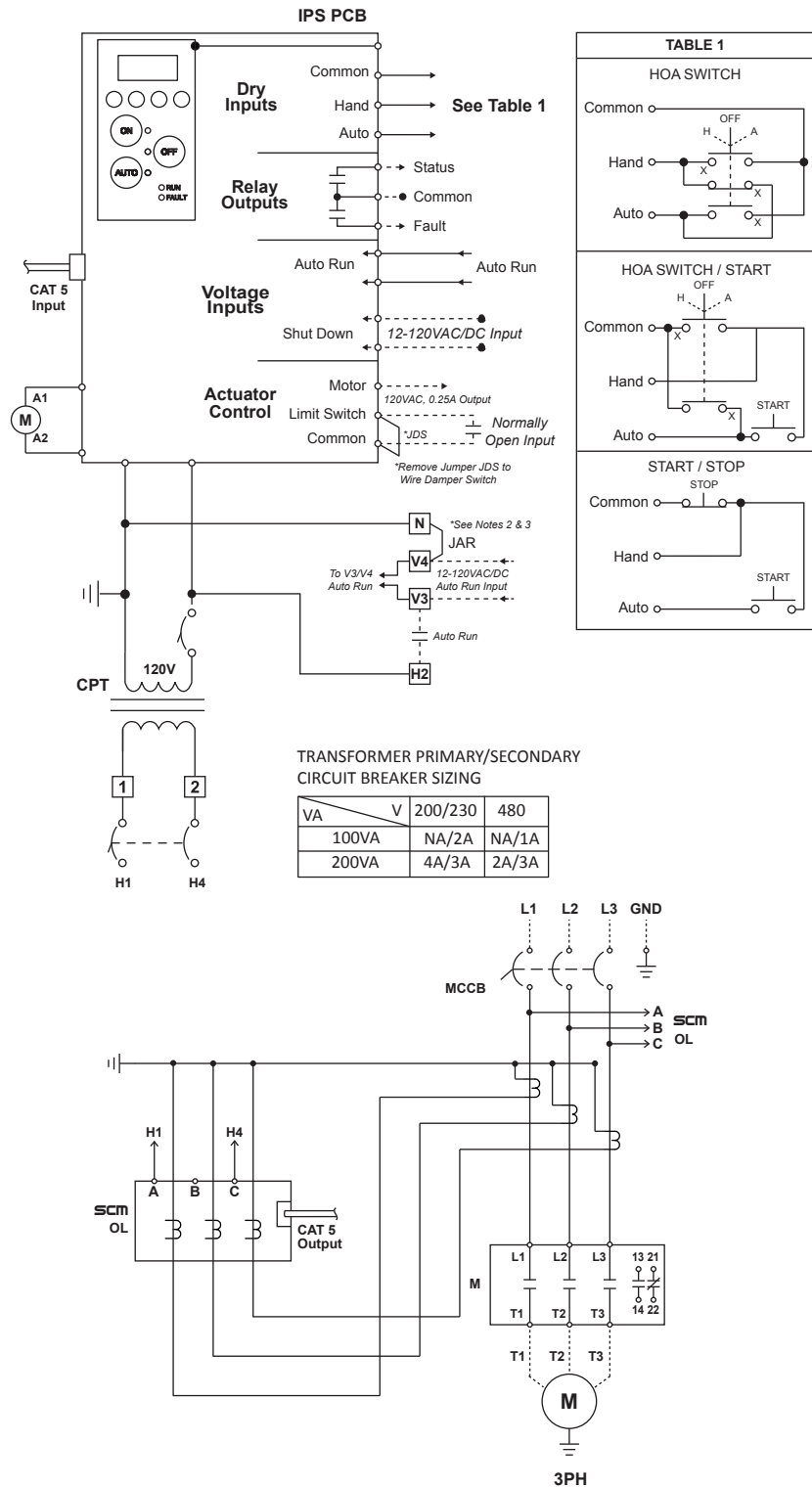

IPS-RV Wiring Schematic (S1~S3P)

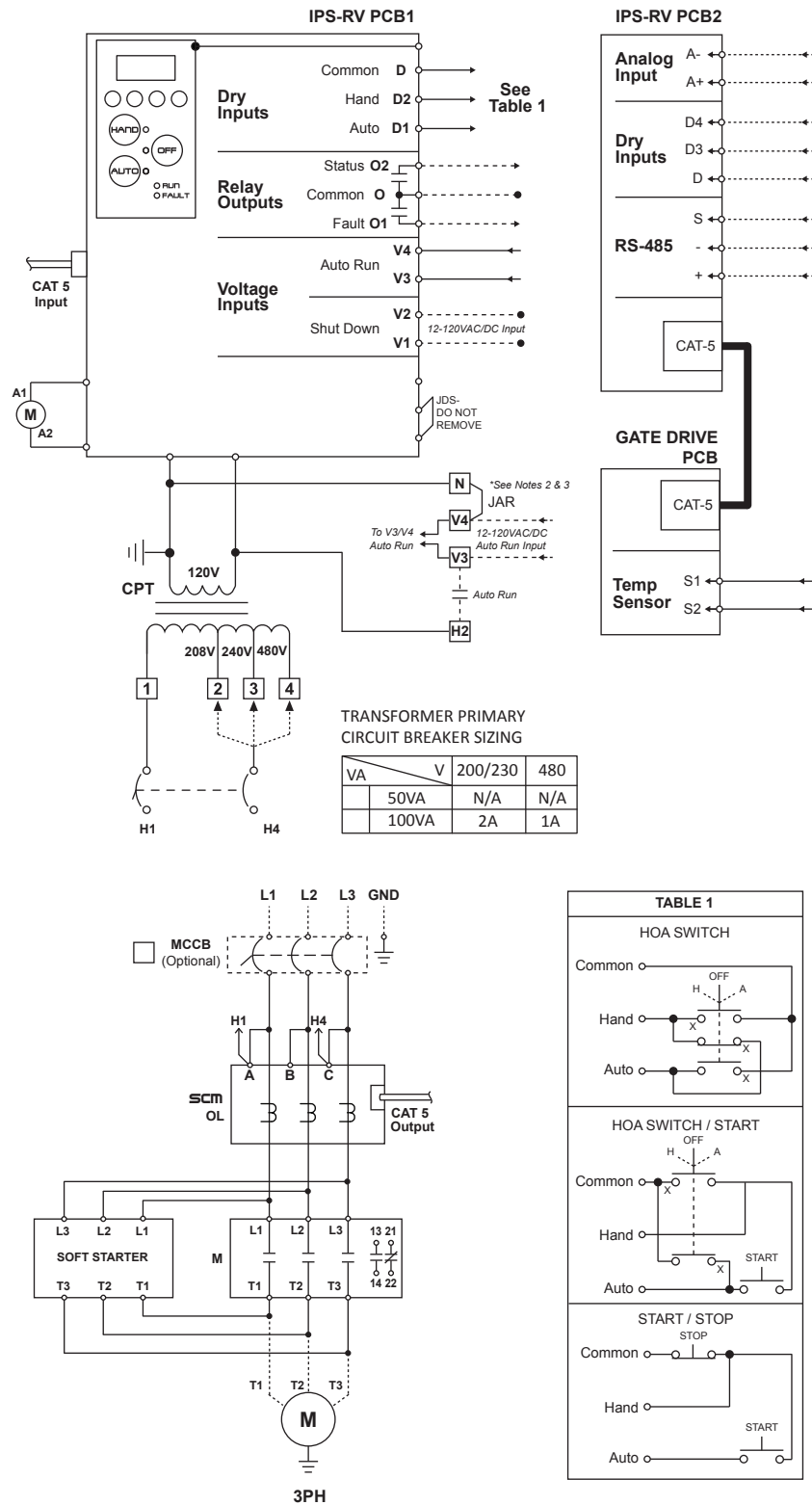

- NOTES:**
1. DASHED LINES INDICATE FIELD WIRING
 2. WHEN JUMPER JAR IS PRESENT, TERMINALS V3 & H2 ACT AS CONNECTIONS FOR A NORMALLY OPEN, DRY CONTACT, AUTO RUN INPUT.
 3. REMOVE JUMPER JAR TO USE V3 & V4 TERMINALS AS A VOLTAGE, AUTO RUN INPUT. APPLY 12-120VAC/DC TO ENERGIZE

SCHM-IPS-RV-V1

IPS-RV Wiring Schematic (S4~S5)

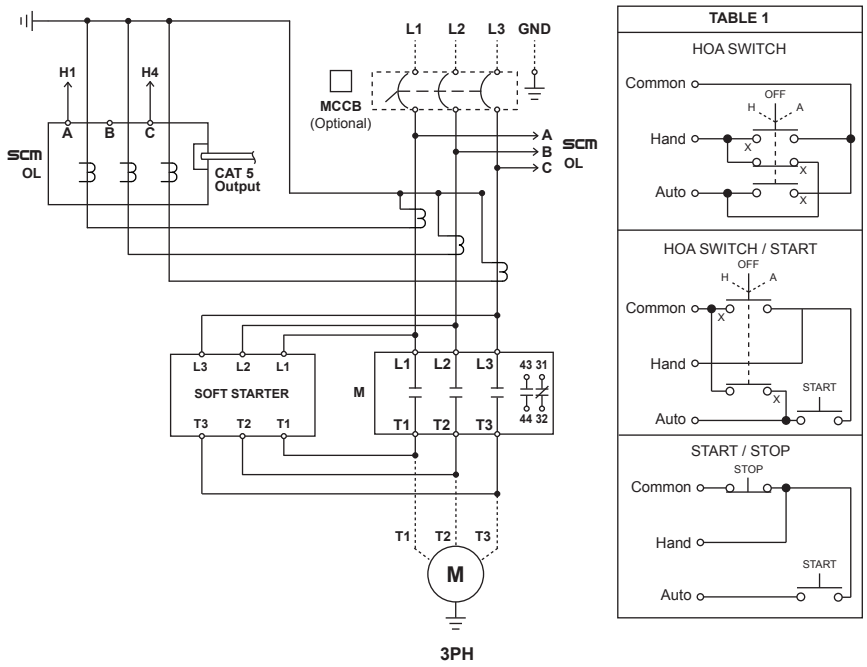
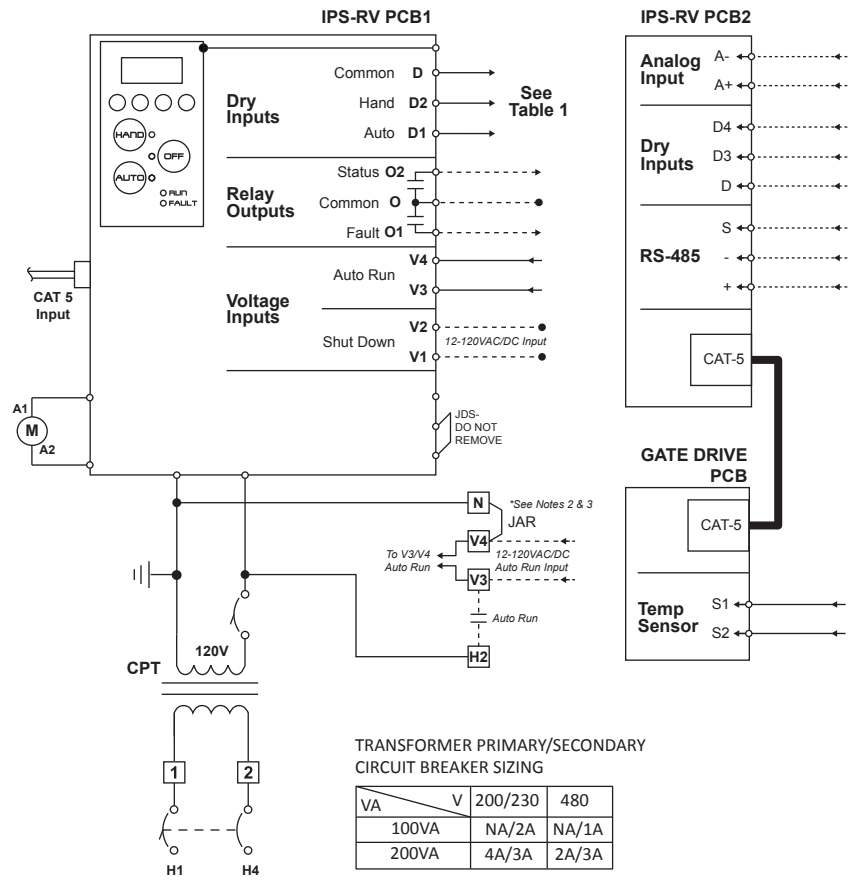

- NOTES:**
1. DASHED LINES INDICATE FIELD WIRING
 2. WHEN JUMPER JAR IS PRESENT, TERMINALS V3 & H2 ACT AS CONNECTIONS FOR A NORMALLY OPEN, DRY CONTACT, AUTO RUN INPUT.
 3. REMOVE JUMPER JAR TO USE V3 & V4 TERMINALS AS A VOLTAGE, AUTO RUN INPUT. APPLY 12-120VAC/DC TO ENERGIZE

4) Operation

Adjustments to protective functions are done through the internally mounted keypad (shown below).

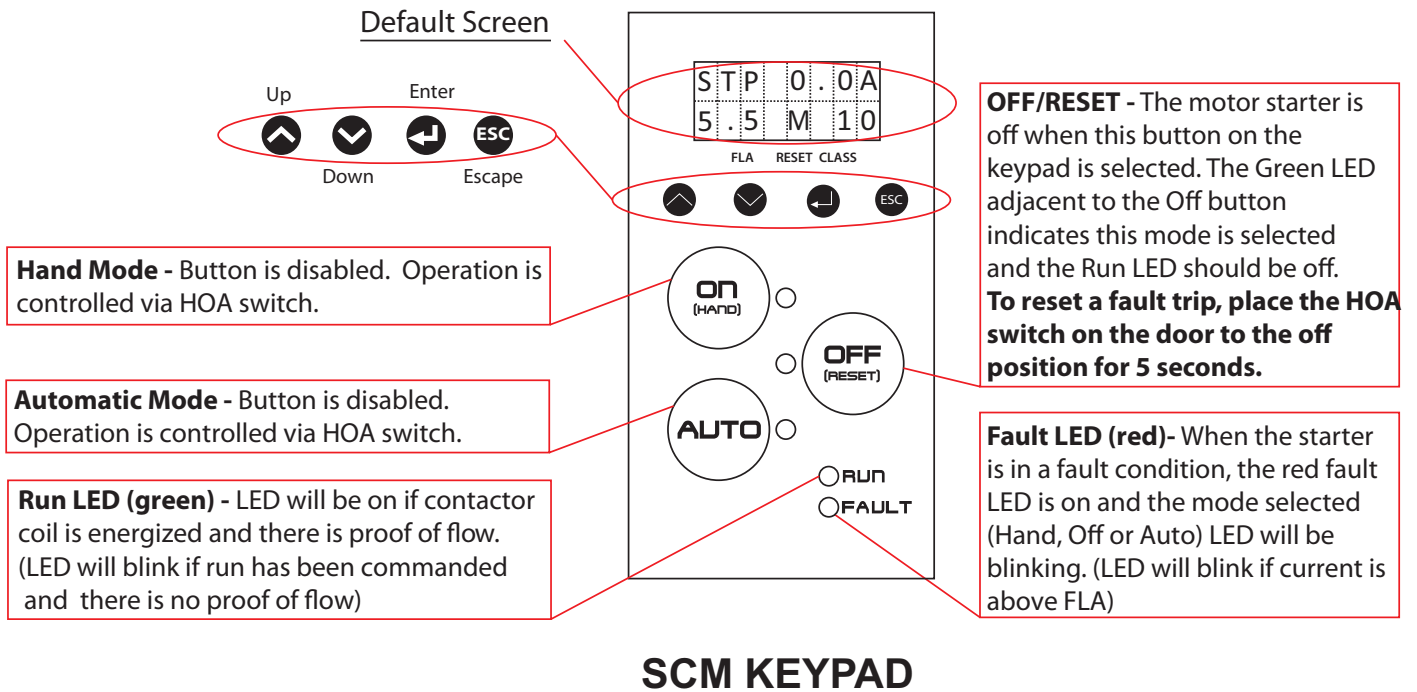

Operation is done via HOA Switch

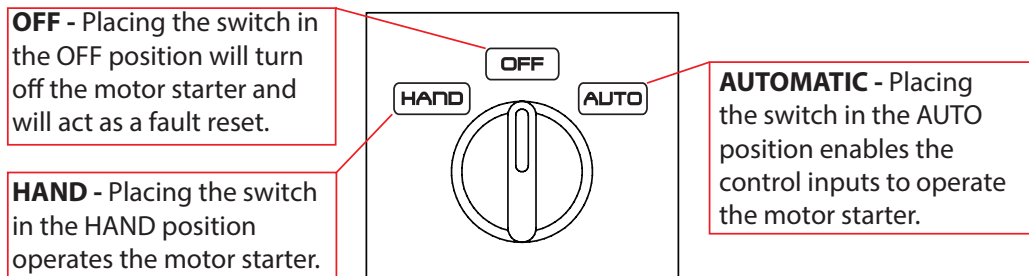

RESET ON
DOOR 5S

Reset on Door - The screen will display this message when there is a conflict between the starters state and the HOA position. Place the HOA in the off position for five seconds to reset the starter.

Lockout Feature

Starters are pre-configured to protect submersible motor applications. If adjustments need to be made to the overload or voltage settings, they must first be unlocked. Follow the steps below to unlock the settings.

- 1)

S	T	P	0	.	0	A
5	.	5	M	1	0	

 +  Press and Hold for 2 Seconds

Press and hold the up and down buttons on the keypad for 2 seconds, or until the screen matches the figure below

S	E	T	T	I	N	G	S
L	O	C	K	E	D		◀

- 2)

S	E	T	T	I	N	G	S
L	O	C	K	E	D		◀

 + 

Press the enter button on the keypad to change the menu from “locked” to “unlocked”, then press escape

S	E	T	T	I	N	G	S
U	N	L	C	K	D		◀

 + 

The lockout feature should now be disabled. Press the escape key to return to the default display screen. Adjustments may now be made to the overload and voltage settings. The lockout feature will automatically re-enable itself after 2 minutes.

Advanced Settings

Unlocking the advanced settings menu will allow the user to cycle through the complete list of motor protection functions and settings. Follow the steps below to unlock the advanced settings menu.

- 1)

S	T	P	0	.	0	A
5	.	5	M	1	0	

 +  Press and Hold for 8 Seconds

Press and hold the up and down buttons on the keypad for 8 seconds, or until the screen matches the figure below.

A	D	V	S	E	T		
L	O	C	K	E	D		◀

- 2)

A	D	V	S	E	T		
L	O	C	K	E	D		◀

 + 

Press the enter button on the keypad to change the menu from “locked” to “unlocked”.

A	D	V	S	E	T		
U	N	L	C	K	D		◀

 + 

The lockout feature should now be disabled. Press the escape key to return to the default display screen.

The advanced settings menu is now accessible by pressing the enter button on the keypad when the default screen is displayed. Use the up and down keys to cycle through the various features of the starter. Press the escape key to return to the default display screen. The lockout feature will automatically re-enable itself after 2 minutes.

Setting Adjustments

The up and down keys will allow the user to scroll through the following. Press the escape key to return to the previous screen. In order to make adjustments to the overload or voltage settings, the Lockout Feature must be disabled (see page 15). In order to access the complete list of motor protection functions, the Advanced Settings Menu must be unlocked (see page 15).

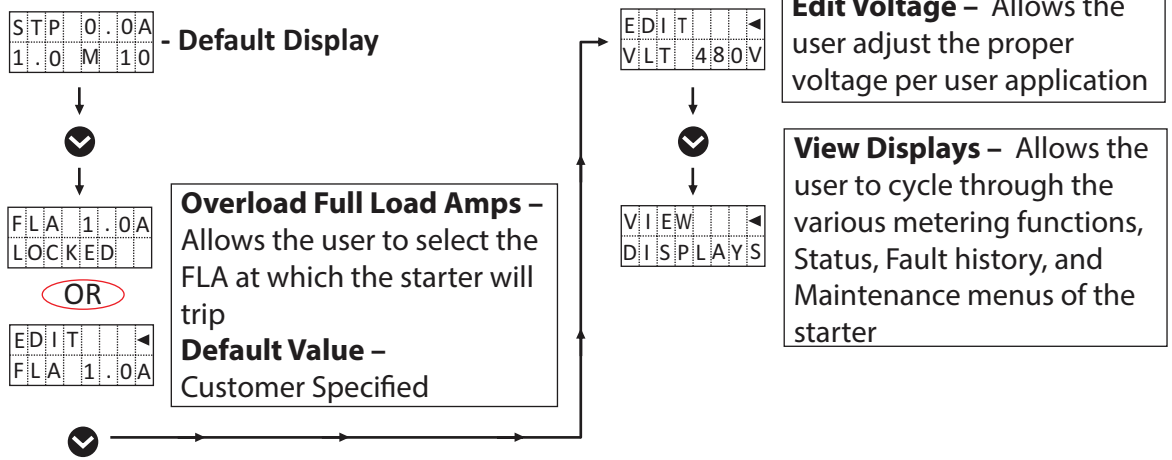

Once the Lockout Feature is disabled, follow the example below to make adjustments to the overload FLA, Ground Fault setting, and Nominal Voltage setting.

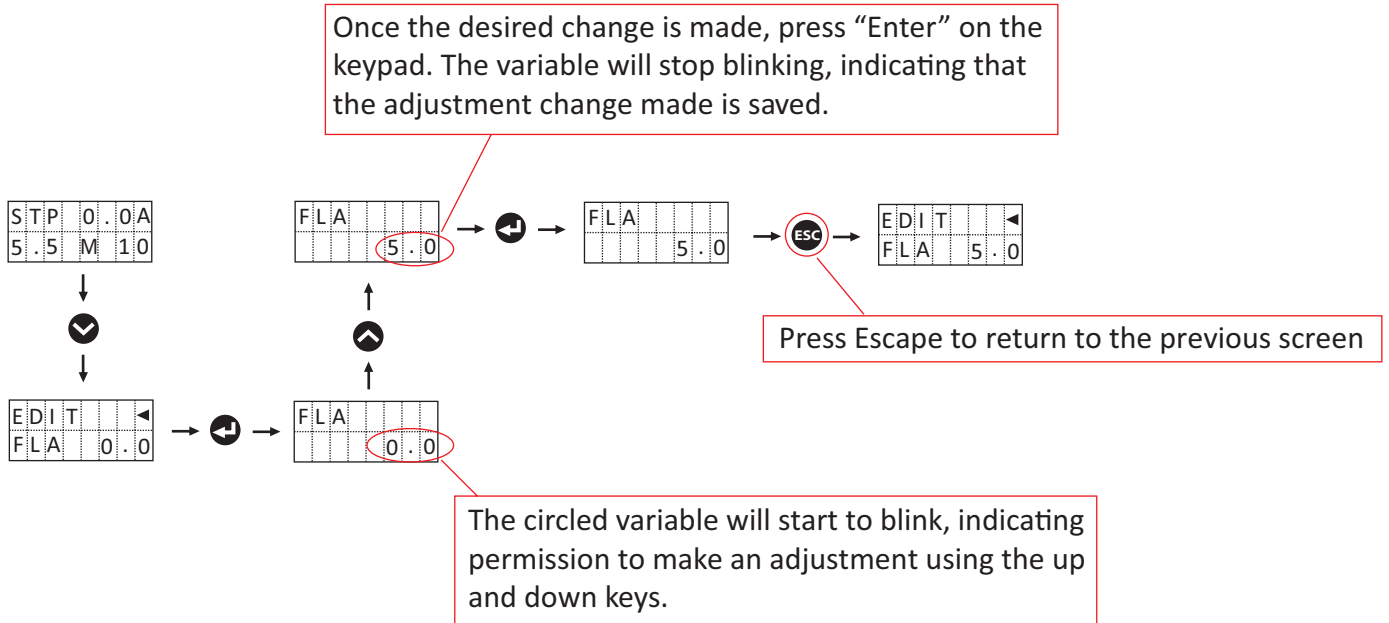

Advanced Settings Menu Structure

	Applicable Starter	Adjustment	Description
	IPS - OPT ----- IPS-RV - STD	Enabled/ Disabled	<ul style="list-style-type: none"> • Communication Control: Disables/enables control (i.e. write commands) via modbus. Communications (i.e. read commands) are always enabled. Default = Disabled
	IPS - OPT ----- IPS-RV - STD	Stop/ No Stop	<ul style="list-style-type: none"> • Communications Loss: In the event of a loss in Modbus communications, the user may select if the starter shall continue to run or stop. Default = No Stop
	IPS - OPT ----- IPS-RV - STD	1-120 Seconds	<ul style="list-style-type: none"> • Loss Time: Detects receipt of any read or write request. When received, resets a running counter which is checked against the COM LOSS parameter. If the timer expires, and COM LOSS is set to STOP, the starter will fault. Default = 1 second
	IPS - OPT ----- IPS-RV - STD	9600,19200, 38400,76800	<ul style="list-style-type: none"> • Baud Rate: Allows the user to select the desired Baud Rate. Default = 9600
	IPS - OPT ----- IPS-RV - STD	1-247	<ul style="list-style-type: none"> • Slave Address: The Modbus address that the starter will respond to. Default = 247
<p>See Next Page</p>	IPS-RV	Volt Ramp, Current Limit, Torque Boost, Direct Start	<ul style="list-style-type: none"> • Start Modes: Voltage Ramp – Provides a linear voltage ramp from the start voltage to line voltage during the user selected time period. Current Limit – Same functionality as voltage ramp. If the current reaches the user defined current threshold, the ramp will pause. If the pause lasts longer than .5 seconds, the unit will trip on locked rotor condition. Torque Boost – Increases the initial voltage by 30% (limit cannot exceed line-voltage). Direct Start – Full voltage start using the SCRs. The unit will bypass after .25 seconds. Default = Voltage Ramp
	IPS-RV	0-30 Seconds	<ul style="list-style-type: none"> • Ramp (Start) Time: Voltage is ramped-up over this time period. 3 seconds or less is suggested for Franklin Electric Submersible motors. • Current Limit: Applies only when start mode is set to Current Limit. Voltage ramp will hold if current limit is reached. Default = 400%
	IPS-RV	100-500%	<ul style="list-style-type: none"> • Start Voltage: The voltage will ramp-up to full voltage from this starting point. 70% is recommended for Franklin Electric Submersible motors. Default = 70%
	IPS-RV	Coast, Volt Ramp, Linear Deceleration	<ul style="list-style-type: none"> • Stop Modes: Coast to Stop – Motor will disconnect from line, allowing the motor to coast to stop. (Recommended for Franklin Electric Submersible motors) Voltage Ramp – Ramps the voltage down to the user defined stop voltage over the selected time period Linear Deceleration – Ramps the voltage down to the stop level, following an exponential curve. Provides a more linear deceleration for motors. (May reduce water-hammer effect) Default = Coast to Stop
	IPS-RV	0-30 Seconds	<ul style="list-style-type: none"> • Ramp (Stop) Time: Voltage is ramped down over this time period. Default = 3 seconds
	IPS-RV	10-100%	<ul style="list-style-type: none"> • Stop Voltage: The voltage will ramp-down to the user defined % of line voltage, then coast to stop. Default = 70%
	IPS-RV	Enable / Disable	<ul style="list-style-type: none"> • Disable Soft Starter: When set to Disable, all soft start related features, alarms and faults. Default = Enabled



























Advanced Settings Menu Structure Continued...

	Applicable Starter	Adjustment	Description
	STD - ALL	ON / OFF	Backspin Delay: This delay operates in both hand and auto modes. Provides a minimum delay between a stop and the next allowed start. Backspin delay prevents rapid restarting.
	STD - ALL	0 - 9999 Seconds	<ul style="list-style-type: none"> • On/Off: Feature is disabled when OFF. Default = OFF • Delay Time: Minimum delay between stop and the next allowed start. Default = 30 seconds
	STD - ALL	ON / OFF	On Delay: This delay operates in both hand and auto modes. Provides a delay from start commanded until motor started.
	STD - ALL	0 - 9999 Seconds	<ul style="list-style-type: none"> • On/Off: Feature is disabled when OFF. Default = OFF • Delay Time: Minimum delay from start command until motor started. Default = 30 seconds
	STD - ALL	OFF / ON	Runtime Delay: Operates in auto mode only. Enforces a minimum run time on the system. When an auto run command is received, the delay begins. If the auto run command is removed before the delay expires, the starter will remain on for the duration of the delay. If the auto run command is removed after the delay expires, the starter will stop normally. Manually turning the starter off, or entering shutdown will stop the starter normally.
	STD-ALL	0-9999 Seconds	<ul style="list-style-type: none"> • On/Off: Feature is disabled when OFF. Default = OFF • Delay Time: Minimum duration of the starter operation. Default = 30 seconds
	STD - ALL	OFF / ON	Off Delay: Operates in auto mode only. When the auto run command is removed the starter will continue powering the motor for the duration of the off delay. Manually turning the starter off or entering shutdown will stop the starter normally.
	STD - ALL	0-9999 Seconds	<ul style="list-style-type: none"> • On/Off: Feature is disabled when OFF. Default = OFF • Delay Time: Duration of the continued run after the removal of an auto run signal. Default = 30 seconds
	IPS - OPT ----- IPS-RV - STD	DISABLED / FILL / DRAIN	Float Switches: This enables or disables float switch functionality on the Modbus option board. For more information see the float switch description in Appendix C. Default = Disabled
	STD - ALL	ENABLE / DISABLE	<ul style="list-style-type: none"> • Shutdown Disable: Disables the ability to use the Shutdown terminal. Default = Enabled
	IPS - OPT ----- IPS-RV - STD	NO / NC	<ul style="list-style-type: none"> • Dry Input 3: Programmable NO or NC contact. Acts as an auto run command to the starter by default. Default = NO
	IPS - OPT ----- IPS-RV - STD	NO / NC	<ul style="list-style-type: none"> • Dry Input 4: Programmable NO or NC contact. No action by default. Default = NO
	IPS-RV	GENERAL / SHUNT TRIP	Fault Output: Allows the user to specify the fault relay behaviour. General fault option will close the fault relay during any fault condition. Shunt trip option will close the fault relay only when a Phase Failure fault occurs. If the shunt trip breaker option is installed power to the starter will be removed until the circuit breaker is reset. This will prevent any motor leads from having a voltage on them in the case of a SCR shorting. CAUTION: Motor lead(s) may become energized when breaker is reset. Default = General
	STD - ALL	LOCKED / UNLOCKED	HOA Keys: Allows the user to lock or unlock the use of the HOA keys on the SCM keypad. Default = Unlocked











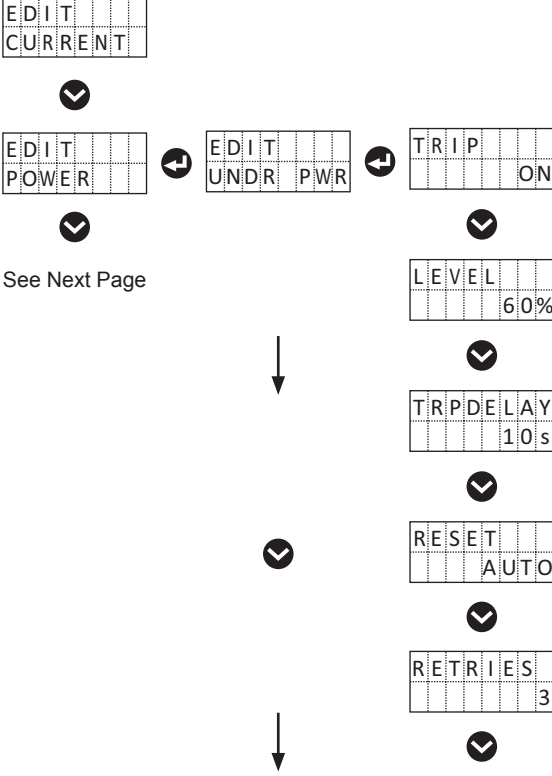

Advanced Settings Menu Structure Continued...

	Applicable Starter	Adjustment	Description
EDIT CONTROL	STD - ALL	ON / OFF	Cycle Fault: On/Off: Trips when an unusually high amount of motor starts and stops are detected. (rate > 20/min) Default = ON
EDIT CYCL FLT ON	STD - ALL	OFF, LAST, ADVANCED	Power Fail Modes: Allows the user to select the return mode of the starter in the event of a power failure. Off: Will return to the OFF state Last: Will return to the last mode the starter was in (Hand, Off, or Auto) Advanced: Will return the starter to the OFF state if the power failure is > 2 seconds Default = Last
EDIT RETURN	STD-ALL	OFF/LAST	Shutdown Return State: Allows the user to select what state the starter will return to after a shutdown command occurs. Off: Starter will always return to off mode. Last: Starter will return to Hand or Auto mode. Default = OFF CAUTION: Removal of the shutdown signal may cause equipment to unexpectedly energize, please ensure affected equipment is clear before terminating shutdown signal if LAST is selected.
EDIT VOLTAGE	STD-ALL	120V- 600V	Nominal Voltage: Allows the user to select the nominal voltage per user application. (120V not available for IPS-RV) Default = 480V
See Next Page	STD - ALL	ON / OFF	OV/UV: Trips when the measured voltage is over or under the nominal voltage. <ul style="list-style-type: none"> On/Off: Trip is disabled when OFF. Alarm is still displayed. Default = ON Level: % Level over or under the nominal voltage, at which OV/UV Trip occurs. Default = 15% Trip Delay Time: Minimum delay between stop and the next allowed start in the event of an OV/UV Trip. Default = 10 sec. Reset Mode: Allows the user to select between manual and automatic reset of the starter in the event of an OV/UV trip. Default = Automatic Reset Retries: Maximum number of reset retries the SCM will attempt in the event of an OV/UV trip when Reset Mode is set to Automatic. Default = 3 retries Reset Delay: Time between reset retries in the event of an OV/UV trip when Reset Mode is set to Automatic. Default = 300 seconds
EDIT OV/UV	STD - ALL	± 5% - 25%	
LEVEL +/- 15%	STD - ALL	0 - 99 Seconds	
TRIP DELAY 10s	STD - ALL	Manual/ Auto	
RESET AUTO	STD - ALL	0-5	
RETRIES 3	STD - ALL	5 - 9999 Seconds	
RST DELAY 300s	STD - ALL	1% - 50%	Voltage Phase Loss: A trip will occur when the percentage of deviation between any one phase and the average voltage is greater than the selected % level. Default = 5%
PH LOSS	STD - ALL	ON / OFF	Voltage Phase Unbalance: A trip will occur when there is a voltage unbalance on all three phases. <ul style="list-style-type: none"> On/Off: Trip is disabled when OFF. Alarm is still displayed. Default = ON Unbalance Level: Trip will occur when the percentage of deviation between any one phase and the average voltage is greater than the selected % level. Default = 3%
VLT UNBL	STD - ALL	1% - 50%	
TRIP ON	STD - ALL	ON / OFF	Reverse Phase: On/Off: Trips when voltage phase sequence is reversed. Alarm is still displayed when set to OFF. Default = ON
REV PHSE	IPS	1 or 3 Phase	# of Phases: The IPS is capable of controlling 1 or 3 phase motors. Not applicable for IPS-RV. Default = 3 Phase
# PHASES 3			

Advanced Settings Menu Structure Continued...

<div style="border: 1px solid black; padding: 2px; display: inline-block;">EDIT VOLTAGE</div>  <div style="border: 1px solid black; padding: 2px; display: inline-block;">EDIT CURRENT</div>  <div style="border: 1px solid black; padding: 2px; display: inline-block;">EDIT OVERLOAD</div>  <div style="border: 1px solid black; padding: 2px; display: inline-block;">FLA 1.0A</div>  See Next Page       <div style="border: 1px solid black; padding: 2px; display: inline-block;">EDIT GND FLT</div>  <div style="border: 1px solid black; padding: 2px; display: inline-block;">TRIP ON</div>  <div style="border: 1px solid black; padding: 2px; display: inline-block;">EDIT CUR UNBL</div>  <div style="border: 1px solid black; padding: 2px; display: inline-block;">TRIP ON</div>  <div style="border: 1px solid black; padding: 2px; display: inline-block;">LEVEL 5%</div>	Applicable Starter	Adjustment	Description
<div style="border: 1px solid black; padding: 2px; display: inline-block;">CLASS 10</div> 	STD - ALL	Differs per model	<p>Overload: Trips according to trip curve in Appendix A.</p> <ul style="list-style-type: none"> FLA: Allows the user to select the appropriate full load amps obtained from the nameplate of the motor to be controlled. For submersible motor applications, this should be set to the published SFA value on the motor nameplate. Default = Customer Specified
<div style="border: 1px solid black; padding: 2px; display: inline-block;">SVC FCTR 1.15</div> 	STD - ALL	5 - 30	<ul style="list-style-type: none"> Trip Class: Allows the user to select the trip class, obtained from the nameplate of the motor to be controlled. Default = 10
<div style="border: 1px solid black; padding: 2px; display: inline-block;">RESET MANUAL</div> 	STD - ALL	0.0 - 2.0	<ul style="list-style-type: none"> Service Factor: The FLA multiplier used to increase the time of the overload trip. See motor nameplate. Default = 1.15
<div style="border: 1px solid black; padding: 2px; display: inline-block;">RETRIES 3</div> 	STD - ALL	Manual / Auto	<ul style="list-style-type: none"> Reset Mode: Allows the user to select between manual and automatic reset of the starter in the event of an overload trip. Default = Automatic
<div style="border: 1px solid black; padding: 2px; display: inline-block;">RST DELAY 300s</div> 	STD - ALL	0 - 5	<ul style="list-style-type: none"> Reset Retries: Maximum number of reset retries the SCM will attempt in the event of an overload trip when Reset Mode is set to Automatic. Default = 3
<div style="border: 1px solid black; padding: 2px; display: inline-block;">COOL DOWN ON</div> 	STD - ALL	5 - 9999 Seconds	<ul style="list-style-type: none"> Reset Delay: Time between reset retries in the event of an overload trip when Reset Mode is set to Automatic. Default = 300 seconds
<div style="border: 1px solid black; padding: 2px; display: inline-block;">LOCK RTR ON</div> 	STD - ALL	ON / OFF	<ul style="list-style-type: none"> Cool Down: Prevents the motor from starting for 3 minutes in the event of an overload condition. Default = OFF
<div style="border: 1px solid black; padding: 2px; display: inline-block;">OUT OF CAL ON</div> 	STD - ALL	ON / OFF	<ul style="list-style-type: none"> On/Off: Trip is disabled when OFF. Alarm is still displayed. Default = ON
<div style="border: 1px solid black; padding: 2px; display: inline-block;">MAX TIME ON</div> 	IPS	ON / OFF	<ul style="list-style-type: none"> On/Off: Prevents setting the overload FLA too high. Fault occurs if the measured inrush current is not between 400% and 1400% of FLA. Default = ON
<div style="border: 1px solid black; padding: 2px; display: inline-block;">TRIP ON</div> 	STD - ALL	ON / OFF	<ul style="list-style-type: none"> On/Off: Fault will occur if after starter is running for 10 seconds with the current above 200% of FLA and is decreasing. Default = ON
<div style="border: 1px solid black; padding: 2px; display: inline-block;">LEVEL 1A</div> 	STD - ALL	ON / OFF	<p>Ground Fault: Trips according to trip curve in Appendix A. Trips when there is a leakage of current to the ground, greater than the amperage level. Not available on models above 95A.</p> <ul style="list-style-type: none"> On/Off: Trip is disabled when OFF. Alarm is still displayed. Default = ON
<div style="border: 1px solid black; padding: 2px; display: inline-block;">TRIP ON</div> 	STD - ALL	1A - 9.9A	<ul style="list-style-type: none"> Level: Allows the user to select the amperage level at which a ground fault trip will occur. Default = 1A
<div style="border: 1px solid black; padding: 2px; display: inline-block;">LEVEL 5%</div> 	STD - ALL	ON / OFF	<p>Current Unbalance: Trips when there is a current unbalance on all three phases.</p> <ul style="list-style-type: none"> On/Off: Trip is disabled when OFF. Alarm is still displayed. Default = OFF
<div style="border: 1px solid black; padding: 2px; display: inline-block;">LEVEL 5%</div>	STD - ALL	5% - 50%	<ul style="list-style-type: none"> Level %: Percentage of deviation between any one phase and the average current, at which point, the SCM will trip. Default = 5%

Advanced Settings Menu Structure Continued...

	Applicable Starter	Adjustment	Description
	STD - ALL	ON / OFF	<p>Under Power: Trips if the measured electrical input falls below selectable level. The expected electrical input is defined as: Nominal Voltage x FLA x Assumed Power Factor of 0.8.</p> <ul style="list-style-type: none"> • On/Off: Trip is disabled when OFF. Alarm is still displayed. Default = ON
	STD - ALL	0% - 99%	<ul style="list-style-type: none"> • Level %: Allows the user to select the % level of expected electrical input, at which trip occurs. Default = 60%
	STD - ALL	0 - 99 Seconds	<ul style="list-style-type: none"> • Trip Delay: Minimum delay between stop and the next allowed start in the event of an under power trip. Default = 10 seconds
	STD - ALL	Manual / Auto / Dry Well	<ul style="list-style-type: none"> • Reset Mode: Allows the user to select between manual and automatic reset of the starter in the event of an under power trip. Dry Well will allow the user to reset an infinite number of times, based on a time delay of up to 48hrs. Default = Automatic
	STD - ALL	0 - 5	<ul style="list-style-type: none"> • Reset Retries: Maximum number of reset retries the SCM will attempt in the event of an under power trip when Reset Mode is set to Automatic. If Reset Mode is set to Dry Well, this setting will be ignored. Default = 3
	STD - ALL	5 - 48hrs	<ul style="list-style-type: none"> • Reset Delay: Time between reset retries in the event of an under power trip when Reset Mode is set to Automatic or Well Recovery. Default = 300 seconds
	STD - ALL	ON / OFF	<p>Over Power: Trips if the measured electrical input is greater than the selectable level. The expected electrical input is defined as: Nominal Voltage x FLA x Assumed Power Factor of 0.8.</p> <ul style="list-style-type: none"> • On/Off: Trip is disabled when OFF. Alarm is still displayed. Default = OFF
	STD - ALL	101% - 200%	<ul style="list-style-type: none"> • Level %: Allows the user to select the % level of expected electrical input at which trip occurs. Default = 120%
	STD - ALL	0.125 - 1000	<ul style="list-style-type: none"> • Trip Delay: Minimum delay between stop and the next allowed start in the event of an over power trip. Default = 10 seconds
	STD - ALL	Manual/ Auto	<ul style="list-style-type: none"> • Reset Mode: Allows the user to select between manual and automatic reset of the starter in the event of an over power trip. Default = Manual
	STD - ALL	0 - 5	<ul style="list-style-type: none"> • Reset Retries: Maximum number of reset retries the SCM will attempt in the event of an over power trip when Reset Mode is set to Automatic. Default = 3 retries
	STD - ALL	5 - 9999 Seconds	<ul style="list-style-type: none"> • Reset Delay: Time between reset retries in the event of an over power trip when Reset Mode is set to Automatic. Default = 300 seconds

Advanced Settings Menu Structure Continued...

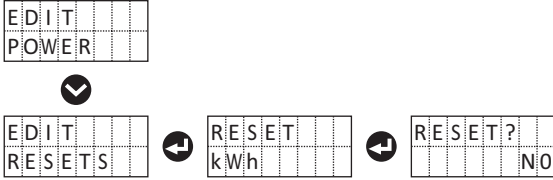
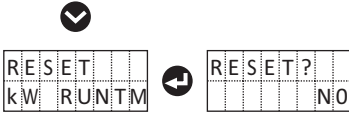
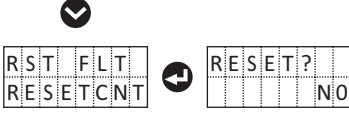
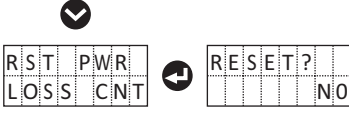
	Feature	Adjustment	Description
	STD - ALL	NO / YES	<u>kWh Reset</u> <ul style="list-style-type: none"> Resets the SCM kWh clock.
	STD - ALL	NO / YES	<u>kW Runtime Reset</u> <ul style="list-style-type: none"> Resets the SCM kW runtime clock.
	STD - ALL	NO / YES	<u>Fault Count Reset</u> <ul style="list-style-type: none"> Resets the SCM fault count.
	STD - ALL	NO / YES	<u>Power Loss Count Reset</u> <ul style="list-style-type: none"> Resets the SCM power loss count.

Display Features

To view the display features of the IPS or IPS-RV, follow the steps below using the keypad.

S	T	P	0	.	0	A
5	.	5	M	1	0	

(Default Display Screen)



x4

V	I	E	W				
D	I	S	P	L	A	Y	S



V	I	E	W				
M	E	T	E	R	I	N	G



V	I	E	W			
V	O	L	T	A	G	E



DISPLAY (Read Only)	
Average Voltage	C-A Voltage
A-B Voltage	Line-Neutral Voltage
B-C Voltage	Frequency



V	I	E	W			
C	U	R	R	E	N	T



Maximum Current	Estimated Trip Time
Phase A Current	Estimated Cool down Time
Phase B Current	CT Ratio
Phase C Current	SCR Temperature (IPS-RV only)
Ground Current	



V	I	E	W	
P	O	W	E	R



Kilowatts	Power Factor
Kilovolt-Amperes	Kilowatt Hours
Kilovolt-Ampere-Reactance	



V	I	E	W		
S	T	A	T	U	S



V	I	E	W		
I	N	P	U	T	S



Auto Run Input	Analog Input (IPS-RV/Modbus only)
Shutdown Input	Communications (IPS-RV, IPS-Optional)
Dry Input 3 (IPS-RV/Modbus only)	
Dry Input 4 (IPS-RV/Modbus only)	

See Next Page



V	I	E	W			
O	U	T	P	U	T	S



FAULT	RUN
-------	-----



V	I	E	W		
O	P	T	B	R	D



Views installed option board



V	I	E	W	k	W	
R	U	N	T	I	M	E



kW Runtime (years-months)	kW Runtime (minutes-seconds)
kW Runtime (days-hours)	



V	I	E	W			
S	Y	S	T	I	M	E



System Time (years-months)	System Time (minutes-seconds)
System Time (days-hours)	



P	W	R	L	O	S	S
						5

View the number of times the unit has been powered off

Display Features Continued

VIEW
STATUS



VIEW
FAULTS



VIEW
FLT HIST



Faults 1-15



VIEW
RESET CNT



Reset Count



VIEW
FAULT CNT



Displays fault count of each type (up to 255 faults)

ADMIN



VIEW
IP ADDR



IP Address 1

IP Address 2



S/W VERS
7.0.0.6

Software Version



OPT VERS
1.0.2

Option board firmware revision number (If applicable).



GDB VERS
0.0.2

Gate drive board firmware revision (IPS-RV only).



SERIAL #
09094567

Serial #



VIEW
OPTIONS



Application (IPS / IPS-RV)

Option 4

Option 1

Option 5

Option 2

Option 6

Option 3

Fault and Alarm Descriptions

A fault condition will stop motor operation and prohibit starting if its protective function is enabled. Alarm conditions will not prevent operation. An alarm may still be displayed even if the fault trip has been disabled. In order to reset a fault, place the HOA switch in the OFF position for 5 seconds.

Alarm / Fault	Display Text	Type	Description
Locked Rotor	LOCK RTR	Fault	Locked Rotor Fault will occur after 0.5 seconds any time a locked rotor condition is detected. Locked rotor is defined as the measured current being over 300% of FLA and not decreasing over a period of 0.5 seconds.
Overload	OVERLOAD	Fault	Overload Fault depends on the measured current, FLA setting, trip class, and service factor. The time to trip is based on the inverse trip curves in Appendix A.
Voltage Phase Unbalance	VPH UNBL	Fault / Alarm	Voltage Phase Unbalance Fault will occur if any phase voltage is above or below the average voltage by more than the user set level, for the duration of the user set time period.
Voltage Phase Loss	VPH LOSS	Fault	Voltage Phase Loss Fault will occur if any phase voltage is below the average voltage by more than the user set level, for the duration of the user set time period. Cannot be disabled.
Current Phase Unbalance	CPH UNBAL	Fault / Alarm	Current Phase Unbalance Fault will occur if any of the measured phase currents deviates from the average current by more than the user set level, for the duration of the user set time period.
Over Voltage	OVR VOLT	Fault / Alarm	Over Voltage Fault will occur if the average voltage exceeds the nominal voltage by more than the programmed percentage.
Under Voltage	UND VOLT	Fault / Alarm	Under Voltage Fault will occur if the average voltage is below the nominal voltage by more than the programmed percentage.
Cycle Fault	CYC FLT	Fault	Cycle Fault is caused by excessive closure of the contactor. If the closure rate exceeds 20/minute the starter will fault (minimum of 6 closures).
Ground Fault	GND FLT	Fault	Ground Fault is based on the vector sum of the phase currents. Inverse trip curves are provided in Appendix A. Test procedures per UL 1053 are provided in Appendix B. For starter sizes S4 and above, it is suggested that this feature be disabled.
Reverse Phase	REV PHSE	Fault	Reverse Phase Fault will occur if the input voltage phase sequence is measured to be reversed from the default phase ordering sequence.
Under Power	UNDERPOWR	Fault / Alarm	Under Power Fault will occur if the measured electrical input falls below selectable level. The expected electrical input is defined as: Nominal Voltage x FLA x Assumed Power Factor of 0.8. Protects submersible motors against dry-run conditions.

Alarm / Fault	Display Text	Type	Description
Over Power	OVERPOWR	Fault / Alarm	Under Power Fault will occur if the measured electrical input is greater than the selectable level. The expected electrical input is defined as: Nominal Voltage x FLA x Assumed Power Factor of 0.8.
Contactors Alarm	CONTACTOR	Alarm	Contactors Alarm appears when the SCM fails to detect current for 2 minutes after a run command occurs. Indicates that the contactor has failed, become detached, or the limit switch failed to close.
Unexpected Current Flow	FLOW	Alarm	Flow Alarm appears when the SCM detects current when the starter is not given a run command.
Keypad Detached	KEYPAD	Fault / Alarm	Keypad Alarm indicates that the keypad has become detached, damaged or is connected incorrectly.
Meter Base Detached	NO BASE	Fault / Alarm	No Meter Base Alarm is caused when the SCM meter base is detached or damaged. The SCM cannot receive current and voltage data to provide motor protection and metering.
Option Board Issue	OPT BRD	Fault / Alarm	Option Board Alarm occurs when the installed option board becomes detached. It can also indicate if an option board necessary for operation isn't installed. IPS-RV requires installation of the Modbus option board.
Communications Loss	LOSSCOMMS	Fault	Communications Loss Fault indicates that the comms loss timer has expired. The timer is reset every time an external communication event occurs. Modbus option board only. Enabled by setting COMM LOSS parameter to STOP.
Out Of Calibration	OUTOFCAL	Fault / Alarm	Out of Calibration Fault provides a rough check that the system has been setup properly. The fault occurs if the measured inrush current is not between 400% and 1400% of FLA. Disabled on IPS-RV.
Max Time to Start	MAX TIME	Fault / Alarm	Max Time to Start Fault indicates a slow motor start or excessive load. The fault is triggered if after running for 10 seconds the current is above 200% of FLA and decreasing. Disabled on IPS-RV.
Gate Drive Board Communications (IPS-RV only)	GDB COMM	Fault	Gate Drive Board Communications Fault occurs if the option board doesn't detect the gate drive board.
SCR Over Temperature (IPS-RV only)	OVER TEMP	Fault	SCR Over Temperature Fault will occur if the junction temperature of the SCRs exceeds 120°C. This limits operation in excessive heat and load combinations which will damage the electronics. IPS-RV only.
Temperature Sensor issue (IPS-RV only)	TMP SNSR	Fault	Temperature Sensor Fault will occur if the heat sink temperature sensor is damaged or missing.
No Current after Start (IPS-RV only)	NO CRNT	Fault	No Current After Start Fault will be triggered if the SCM doesn't detect current for a period of 5 seconds during soft starter operation. This fault can detect some connection issues with the SCRs and bypass contactor.

Alarm / Fault	Display Text	Type	Description
Float Switch Invalid State (IPS-RV or Modbus only)	FLOAT SW	Fault / Alarm	Float Switch Fault occurs when an invalid float switch state is detected. See SCM float switch description for more information. IPS-RV and-Modbus option board only.
Gate Drive Startup Check Failure (IPS-RV only)	GDB CHK	Fault	GDB Startup Check Failure indicates that the gate drive hardware has detected an error during its startup tests. Check if there are additional alarms in the fault history and correct them. If this fault persists please contact the manufacturer.
Gate Drive Frequency Check Failure (IPS-RV only)	GDB FREQ	Fault	GDB Frequency Check Failure indicates that the frequency measured by the gate drive board is outside of 50-60 Hz +/- 10%. This will often occur if an input or output phase is not connected. Check for additional alarms in the fault history and correct them. If this fault persists please contact the manufacturer.
Phase Failure (IPS-RV only)	PHA FAIL PHB FAIL PHC FAIL	Fault	The Phase Failure Faults will occur on a start if there is no voltage across an SCR or there is no current flowing through the SCR. With the power off verify the motor leads are connected properly.

Appendix A - Overload and Ground Fault Trip Curves

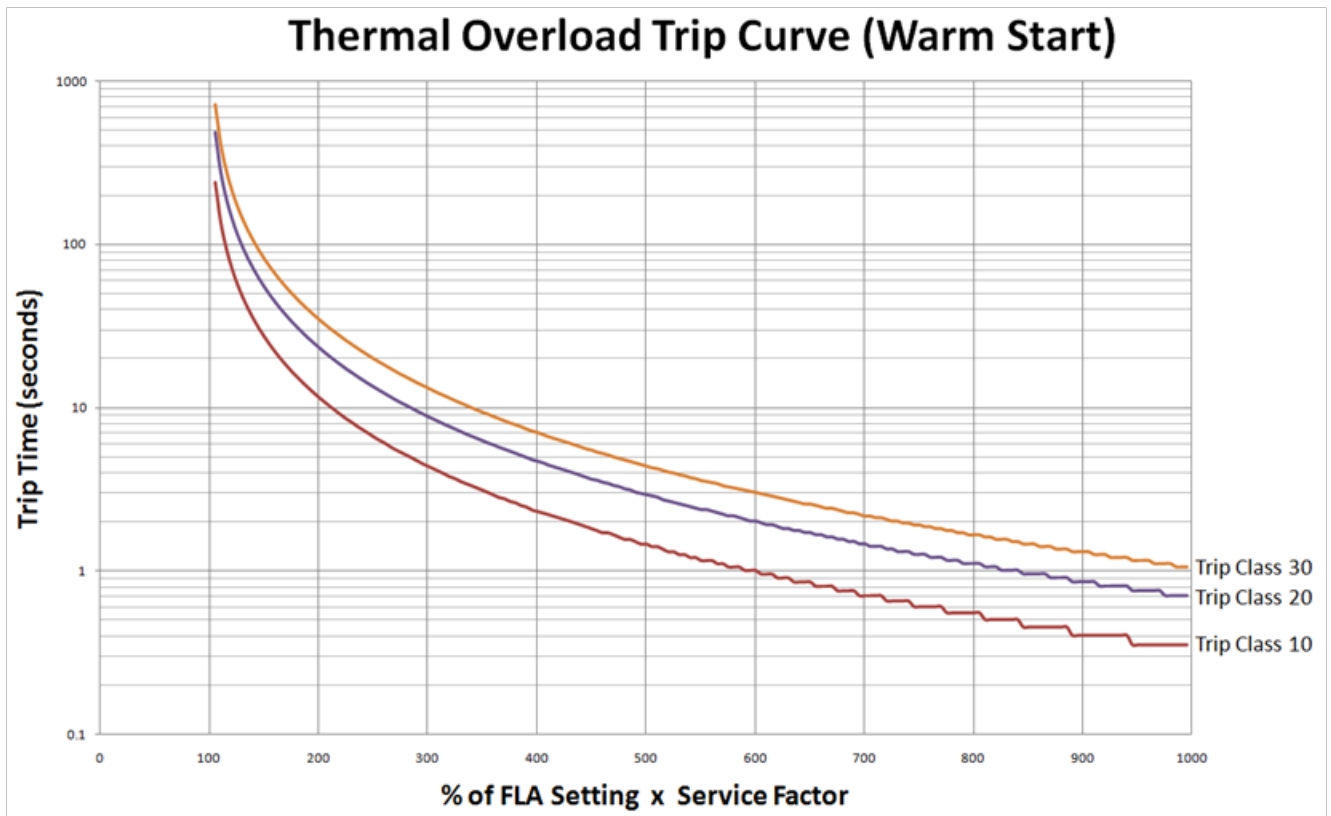
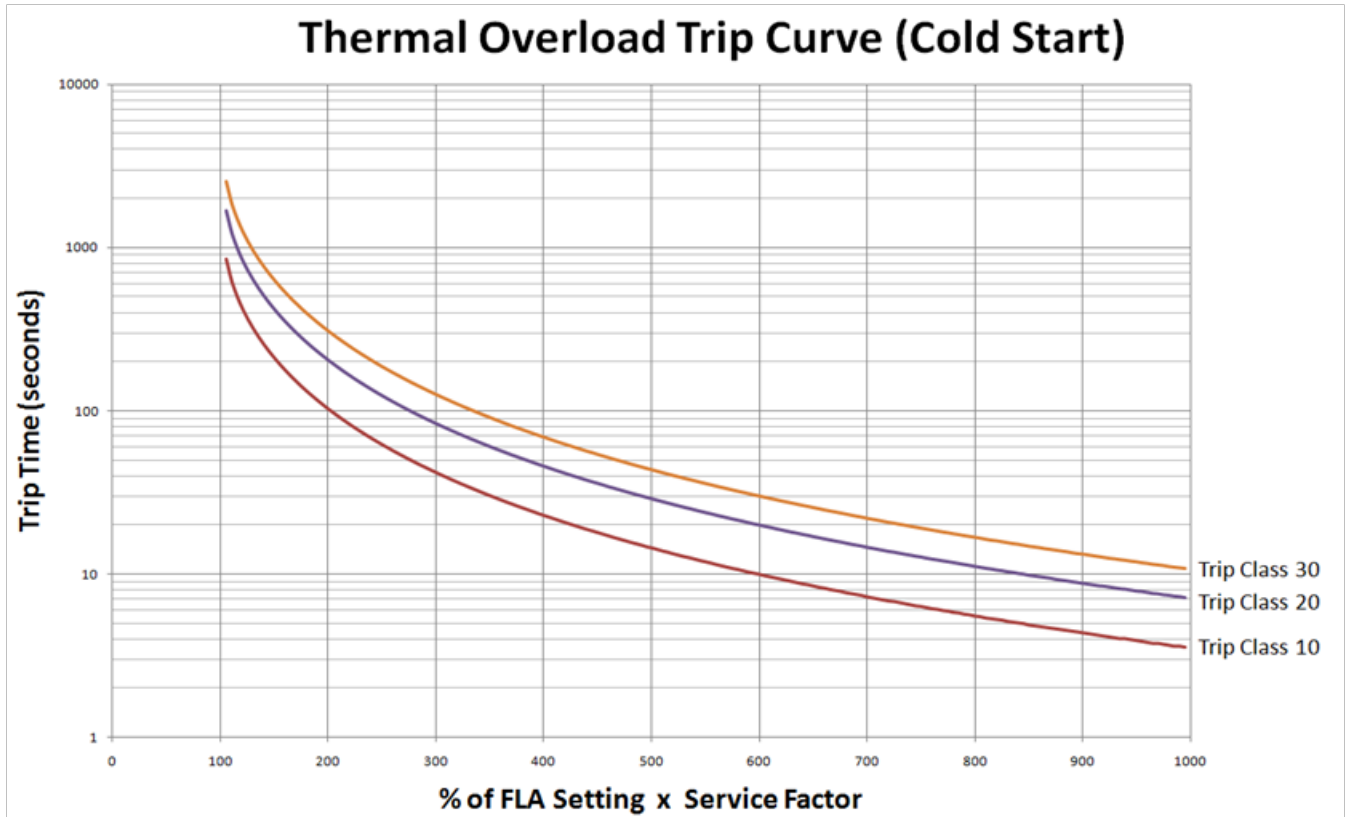

Ground Fault Trip Curve

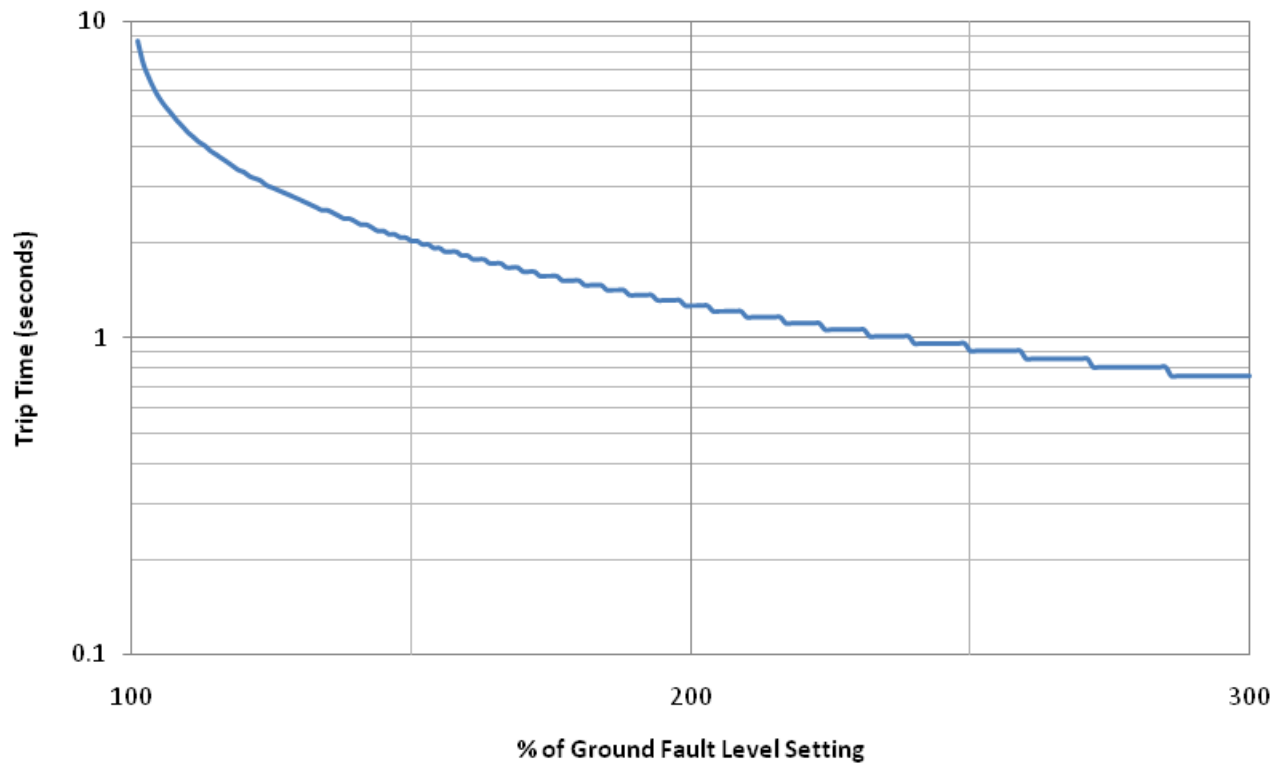

Appendix B - Ground Fault Testing Procedure

- 1) Disconnect Power.
- 2) Connect the three line voltages to the circuit breaker.
- 3) Apply power to starter.
- 4) For test purposed, turn Ground Fault Trip "ON", and set the Ground Fault Level to "1.0A". (Default)
- 5) Using an AC power supply, construct the circuit below. This circuit simulates a ground fault condition by generating a current in one of the phases. Alternate test circuits may be used. The only requirement is the current through the current transformer must be at least 115% of the ground fault setting and pass through only one CT window.

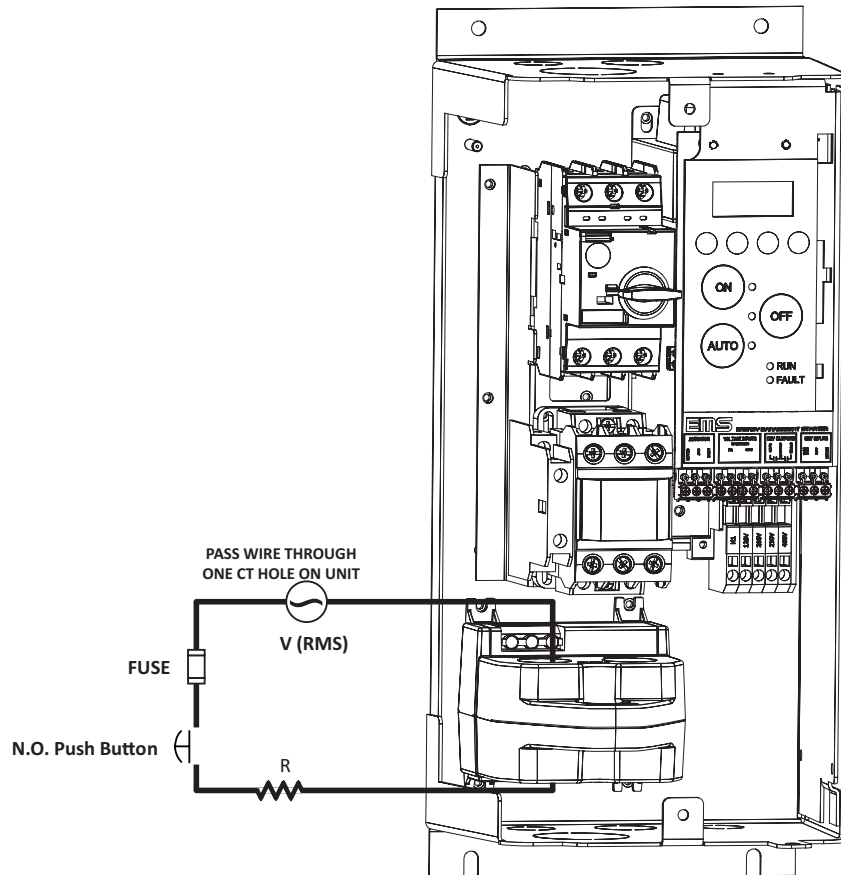

- 6) The values of V and R will be determined by the current required to generate a ground fault trip condition:
 $I = V_{rms}/R$, where $I = 115\%$ of ground fault setting.
- 7) Place the unit in "Hand" mode, apply three phase power, and allow the contactor to close.
- 8) Energize the test circuit by pushing and holding the "N.O. Push Button" until the unit trips. The SCM Display should show a Ground Fault alarm and the N.O. contacts should be open. Release the "N.O. Push Button".

Ground Fault Test Results

Date: _____
Performed By: _____
Trip (Y/N) _____
Location: _____

*Form should be retained by the building's electrical foreman

Appendix C - IPS Option Boards

Ethernet I/O (Fault Logging) Option Board

Ethernet Connections

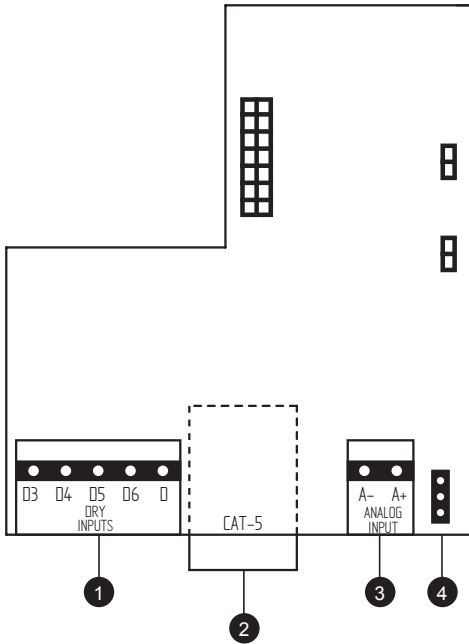

- 1 Dry Contact Inputs
- 2 Ethernet Cable Connection
- 3 Analog Input
- 4 Analog Input Selector Jumper

Dry Contact Inputs	Dry input terminals. Normally open contacts or transistorized inputs.
Ethernet Cable Connection	CAT-5 Cable with RJ-45 Connection
Analog Input	Analog input for 4-20mA, 0-10V or 10KΩ thermistor.
Analog Input Selector Jumper	No Jumper: 0-10V Input Jumper Pin 1 & 2: 10KΩ Thermistor Input Jumper Pin 2 & 3: 4-20mA Input

Ethernet Setup

Establishing Ethernet Connection

- Turn off and disconnect power to the starter
- Connect ethernet cable from the starter's CAT-5 terminal to one of the following:
 - 1) Personal computer (PC will assign IP address)
 - 2) Network (Router will assign IP address)
- After establishing connections, return power to the starter
- Obtain IP address by following the steps below:

Display Screens:

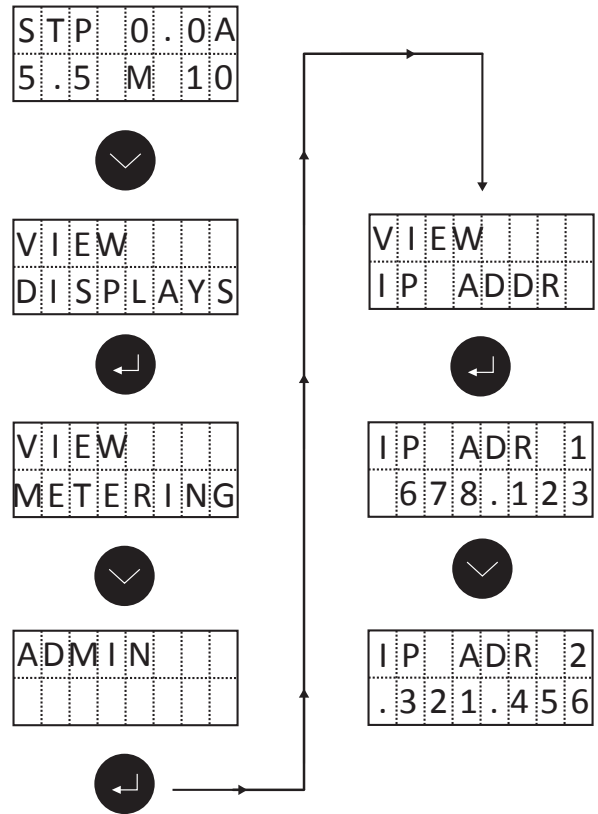

WARNING

- Replace battery with Renata SA, Part No. CR2032RV MFR only. Use of another battery may present a risk of fire or explosion. Contact Cerus Industrial for replacement batteries.
- Battery may explode if mistreated. Do not recharge, disassemble or dispose of in fire.

- In web browser, type IP address (IP address = IP ADR 1 + IP ADR 2)
- After web page loads the user can set the location, description, date, time and view fault history

Tru-Power™ (Power Meter) Option Board

Tru-Power™ Outputs

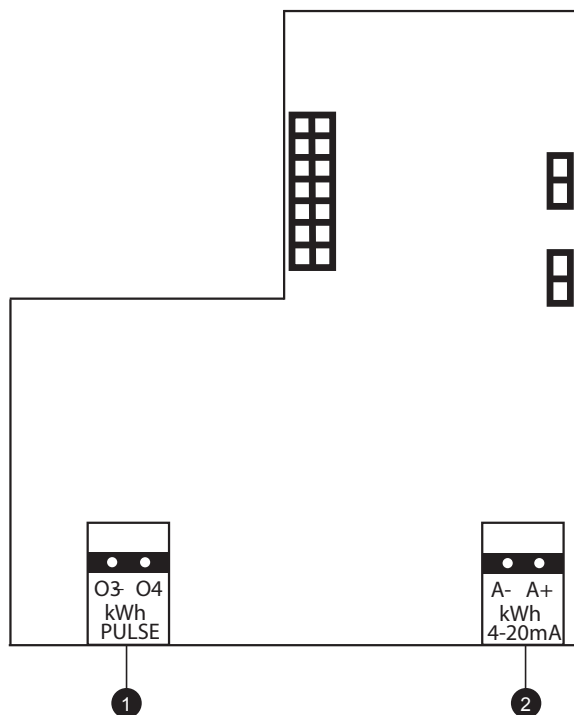

- 1 Digital Pulse Output
- 2 Analog Output

Digital Pulse Output	Solid state output that cycles based on EDIT kWh PULSE parameter settings (Select from 0.25, 0.5, 1, 2). Default setting is 1 kWh per pulse. Output contacts rated at 24 VAC/DC, 150 mA.
Analog Output	4~20 mA analog value for measured kW. 0 measured kW results in 4 mA. kW MAX parameter results in 20 mA. Maximum output rating is 24V, self-powered loop.

Tru-Power™ Parameter Setup

It may be necessary to adjust settings and configure the starter for proper Tru-Power operation. From the Default Display screen, access the parameters to begin setup.

```

ADV
SETTINGS
    
```

In order to edit the Tru-Power operational settings, the Advanced Settings Menu must first be unlocked.



Press ENTER to access the parameters and begin setup.



Use the ARROW keys to access the EDIT POWER settings.

```

EDIT
POWER
    
```



```

EDIT
kWh PULSE
    
```



```

kWh/PULS
1
    
```



```

EDIT kW
4 - 20mA
    
```



```

kW MAX
342 kW
    
```

Set the desired number of kWh per pulses and press ENTER.

Press ESC and use the down arrow to access EDIT kW parameter. Enter the desired output scaling of the 4~20 mA reference signal.

Note: Always set kW MAX parameter based on actual motor sizing. Default value of 342kW may deliver lower resolution in small motor applications. Programming the kW MAX parameter accurately ensures detailed kW consumption output. The analog scale follows the relationship below:

4 mA → 0 kW
 20 mA → MAX kW

Proper parameter mapping of the MAX kW value will ensure accurate scaling.

Modbus Option Board

Gate Drive Board	For soft starter use only
RS-485 (+ - S)	Connect Modbus wiring using provided RS-485 terminals.
Dry Inputs (D D3 D4)	Dry input terminals 3 and 4. N.O. or N.C. software configurable contact or transistorized input. D terminal is common.
Analog Input (A- A+)	Analog input for 4-20mA, 0-10V or 10K Ω thermistor.
Analog Input Selector Jumper	No Jumper: 0-10V Input Jumper Pin 1 & 2: 10K Ω Thermistor Input Jumper Pin 2 & 3: 4-20mA Input
Termination Resistance Switch (OFF ON)	Select the ON position to enable termination resistor for RS-485 communications.

Modbus Parameter Setup

It may be necessary to adjust settings to configure the starter for proper Modbus operation. From the Default Display screen, access the Comms parameters to begin setup. Please note the option board is designed to operate as a slave in Modbus RTU mode only. Serial communications should be set for 8 data bits, even parity and one stop bit.

Display Screen	Instruction / Description
ADV SETTINGS	Press and hold the UP and DOWN buttons for 8 seconds to unlock the Advanced Settings. Press the ENTER button to change the menu from "LOCKED" to "UNLOCKED."
EDIT MODBUS	Press ENTER to access Modbus parameters and begin setup. Use the ARROW keys to navigate through parameters. Press ENTER to confirm your selections.
COM CTRL DISABLED	Setting enables or disables starter control via Modbus.
COM LOSS NO STOP	In the event of a loss in Modbus communications, select if the starter should continue to Run, or Stop operation.
LOSS TM 30s	Detects receipt of any Modbus read or write request. When received, resets a running counter which is checked against the COM LOSS parameter.
BAUD RT 9600	Adjust parameter to the desired Baud Rate 9600, 19200, 34800, or 76800.
SLV ADDR 247	Adjust the slave address the Modbus option board responds to.

Press ESC to return to the Default Display screen.

SCM Float Switch function

Applies to: IPS-RV or IPS with the installation of the Modbus Option board.

2-Wire float switch operation

- Operates in Auto mode only.
- Float switches can be set to Disabled, Fill, or Drain.
- Dry Inputs 3 and 4 are individually programmable N.O. or N.C.
- Dry Input 4 – Set to act as the lower float switch.
- Dry Input 3 – Set to act as the upper float switch.
- Inputs are active when the water is above their level

Fill Operation				
Terminal	Status	Terminal	Status	Operation
D3	Inactive	D4	Inactive	Start Command
D3	Active	D4	Inactive	Continue Last State
D3	Active	D4	Active	Stop Command
D3	Inactive	D4	Active	Invalid State (Fault)

Drain Operation				
Terminal	Status	Terminal	Status	Operation
D3	Active	D4	Active	Start Command
D3	Active	D4	Inactive	Continue Last State
D3	Inactive	D4	Inactive	Stop Command
D3	Inactive	D4	Active	Invalid State (Fault)

To provide system level protection the starter is programmed so that D3 is always the lower float switch and D4 is the upper float switch. For the safest operation it is suggested to use a normally closed switch for the D3 input and a normally open switch for the D4 input. If the starter is configured in this way it will eventually reach an invalid input state if either or both of the inputs are disconnected. Other input configurations are allowed, however input disconnects may cause constant run or stop commands.

Auto inputs may cause unexpected run commands. Always use proper lockout/tagout procedures when working on energized equipment.

Fill Operation

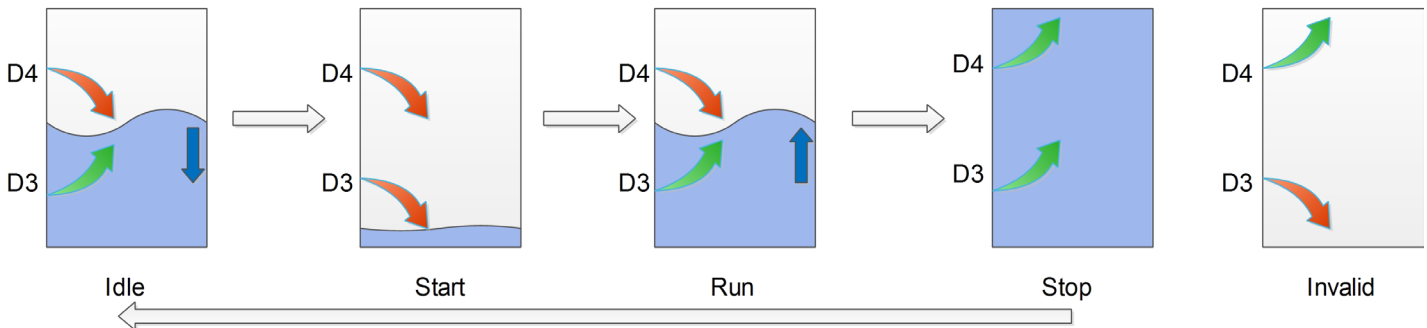

Green arrows indicate that the input is in the active state. Closed if N.O. Open if N.C.



Red arrows indicate that the input is in the inactive state. Open if N.O. Closed if N.C.



Drain Operation

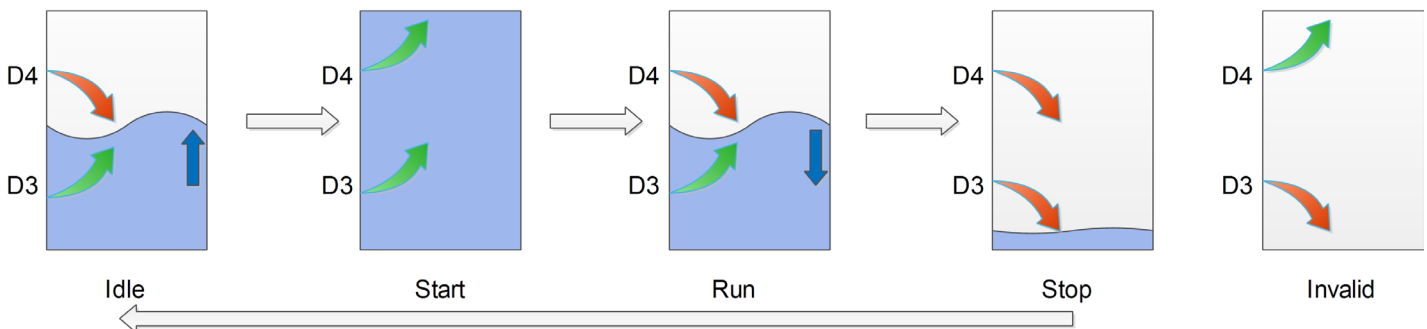

Appendix D - Warranty Information

Manufacturer			Installation (Start-up) Date	
Model Number	IPS, IPS-RV		Warranty Period	
Customer Information	Name			
	Address			
	Tel.			
Sales Offices (Distributor)	Name			
	Address			
	Tel.			

**Warranty period is 12 months after date of installation when used in a motor control application.
Warranty period is 36 months after date of installation when installed with a Franklin Electric Motor and Pump.
Date of installation is not to exceed 18 months from the manufacturing date to qualify for warranty.**

- **Warranty Service Information**

- If the defective part has been identified under normal and proper use within the warranty term, contact and authorized Franklin Electric distributor.

- **Warranty is void if damage to the unit was caused by any of the following**

- Damage was caused by misuse, negligence, or accident.
- Damage was caused by abnormal voltage or peripheral devices' malfunction (failure).
- Damage was caused by improper repair, or altering by someone other than a Franklin Electric authorized distributor or service center.
- Damage was caused by an earthquake, fire, flooding, lightning, or other natural calamities.
- When Franklin Control Systems nameplate is not attached.
- When the warranty period has expired.