

SubDrive Duplex Alternator

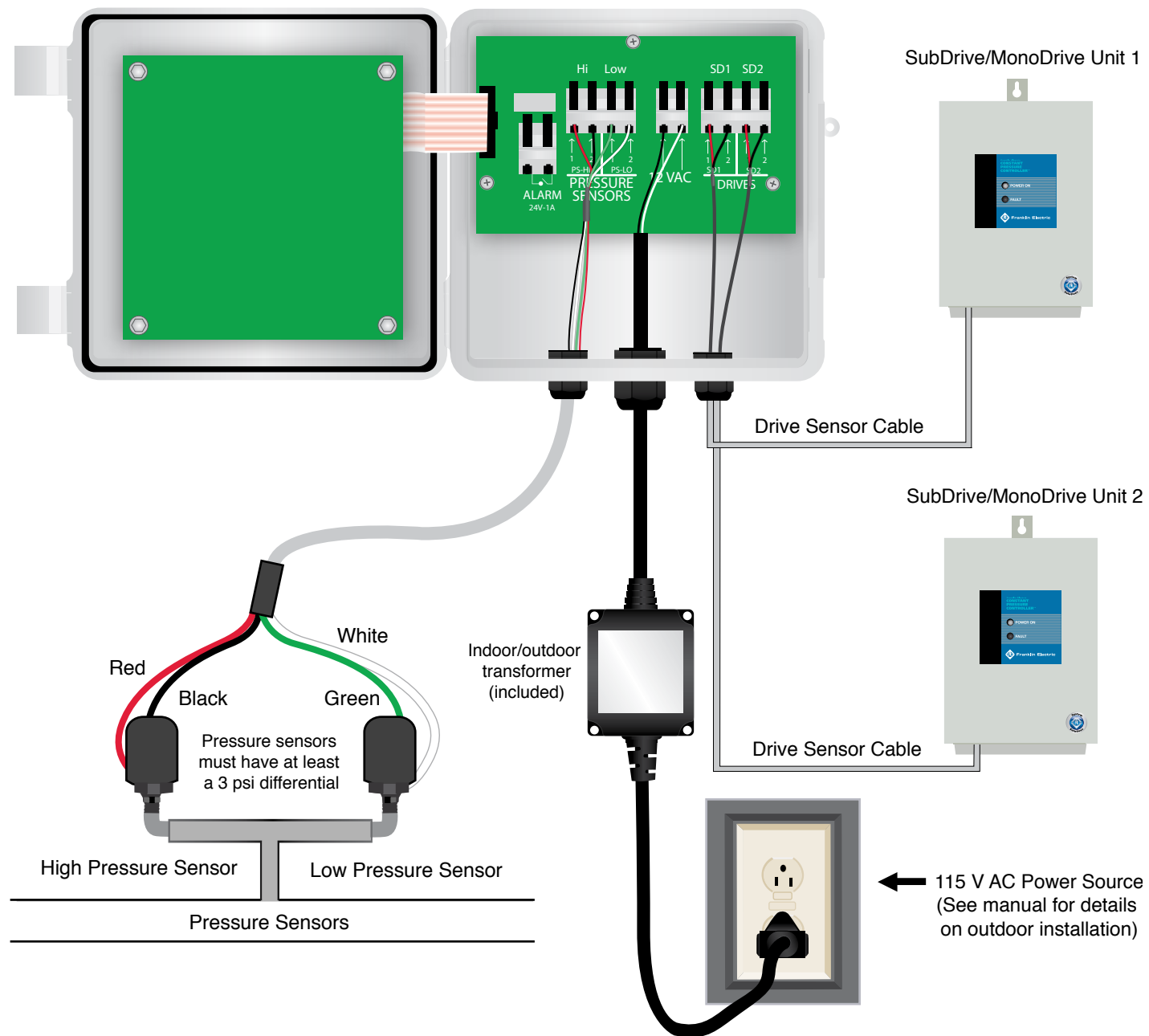

Pressure Sensor Connections

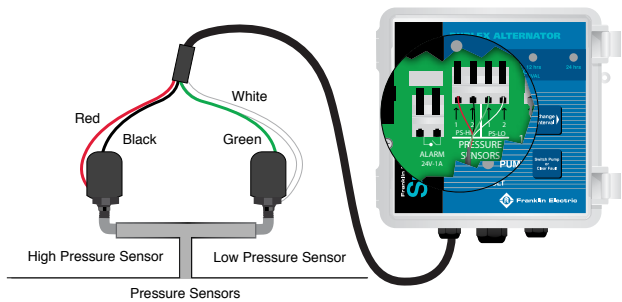

Connect the ends of the four-conductor cable with the spade terminals to the two pressure sensors.

Connect the Red and Black wires to the “high” pressure sensor. Connect the stripped ends of the Red and Black wires to the Alternator (PS-HI). The Red and Black wire connections are interchangeable.

Connect the Green and White wires to the “low” pressure sensor. Connect the stripped ends of the Green and White wires to the Alternator (PS-LO). The Green and White wire connections are interchangeable.

Connecting the SubDrive to the Alternator

SubDrive75/100/150 NEMA 1 MonoDrive/MonoDriveXT NEMA 1 SubDrive2W NEMA 3R

Option A:

Use the two-conductor cable supplied with the Alternator control unit. Cut the quick connect ends off and strip the conductor wires to 0.25” (A). (Note: when used with a SubDrive300, or other NEMA 4 enclosures, the quick connect ends will **not** be cut.) Connect one end to the Drive’s pressure sensor terminals and one end to the Alternator’s Drive input terminals (SD1 or SD2).

Option B:

Use the pressure sensor cable that came with the Drive unit. Cut off the fork terminal ends and strip wires to 0.25” (B). Connect one end to the Drive’s pressure sensor terminals and one end to the Alternator’s Drive input terminals (SD1 or SD2).

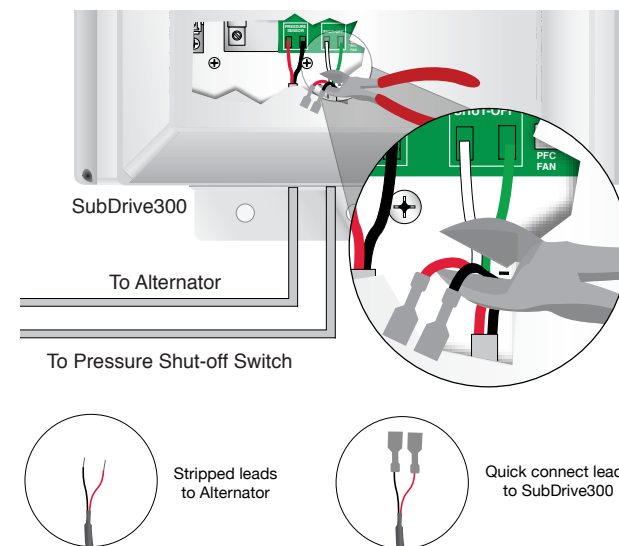
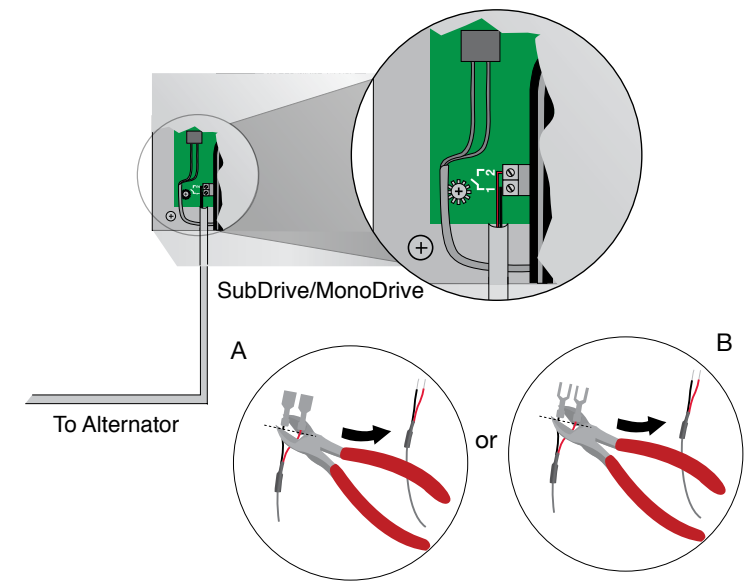

SubDrive300 NEMA 4

Cut the terminals off both ends of the red and black leads of the four-conductor cable supplied with the SubDrive300 (leaving a two-conductor cable with green and white leads). Connect the green and white leads to the SubDrive300’s pressure shut-off switch terminals and to the pressure shut-off switch, as in a normal SubDrive300 installation.

Use the two-conductor cable supplied with the Alternator control unit to connect the SubDrive300’s pressure sensor terminals to the Alternator’s Drive input terminals (quick connects used on the SubDrive300 and stripped leads on the Alternator’s Drive input terminal SD1 or SD2).

SubDrive75/100/150 NEMA 4 MonoDrive/MonoDriveXT NEMA 4

Use the two-conductor cable supplied with Alternator control unit to connect the pressure sensor terminals of the SubDrive to the Alternator. Attach the quick connects to the SubDrive terminals and the stripped leads to the Alternator’s Drive input terminals (SD1 or SD2).

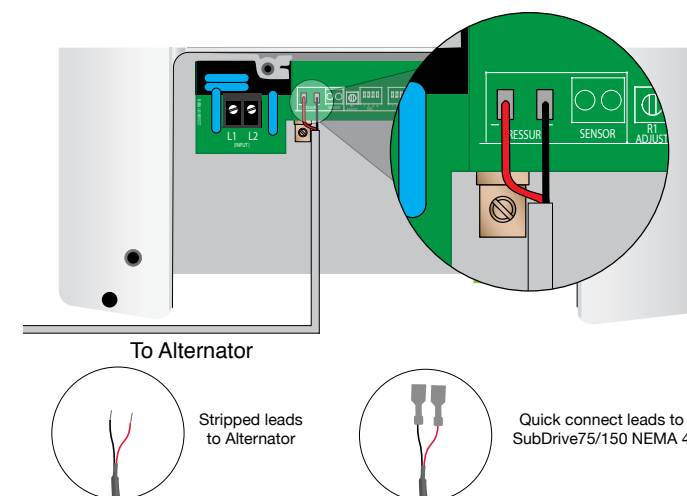

Duplex Inline Constant Pressure System Wiring Guide

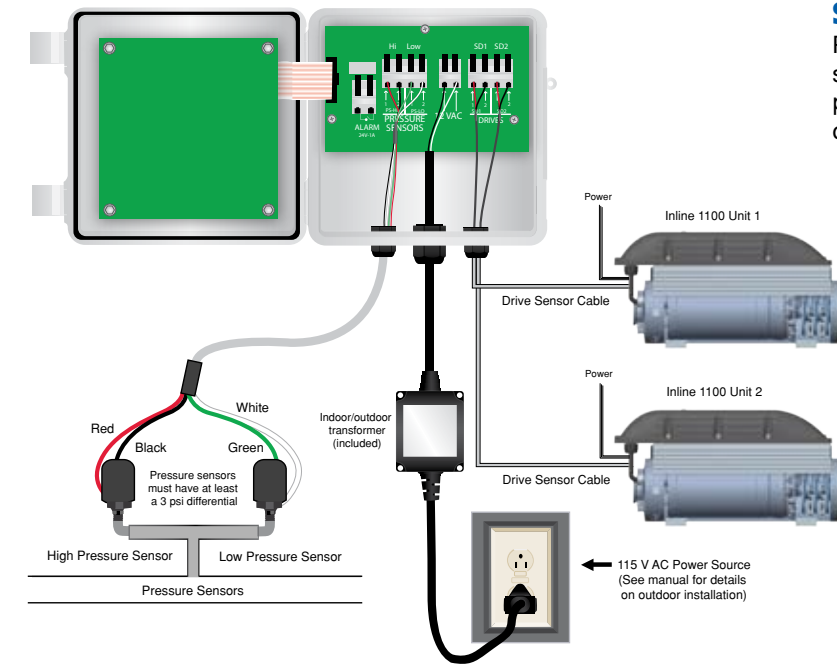

STEP 1
Prior to wiring the duplex alternator, or the InLine CP systems, adjust the low pressure sensor by turning the hex pressure adjustment screw at least 1/4 inch turn counter clockwise (or 3 psi).

STEP 3 Connecting the InLine 1100 to the Alternator

Instructions:
Use the pressure sensor cable that came with the drive unit. Cut off the fork terminal ends and strip wires to 1/4 inch (Figure 1).
Connect one end to the drive's pressure sensor terminals (Figure 2) and one end to the alternator's drive input terminals (Figure 3, labeled SD1 or SD2).

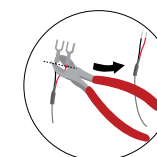

Figure 1

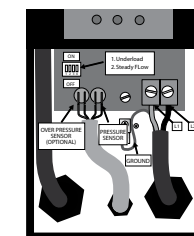

Figure 2:
Inline internal wiring



Figure 3:
Drive cable connection

STEP 2 Pressure Sensor Connections

Connect the ends of the four-conductor cable with the spade terminals to the two pressure sensors.
Connect the red and black wires to the high pressure sensor. Connect the stripped ends of the red and black wires to the alternator (PS-HI). The red and black wire connections are interchangeable.
Connect the green and white wires to the low pressure sensor. Connect the stripped ends of the green and white wires to the alternator (PS-LO). The green and white wire connections are interchangeable.

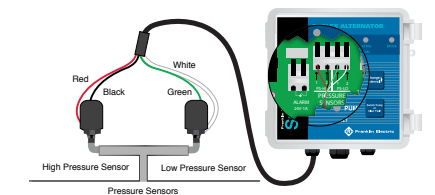

Duplex Alternator Wiring Guide