

Franklin Electric

PUMPTEC

WITH INFRARED REMOTE
Owner's Manual

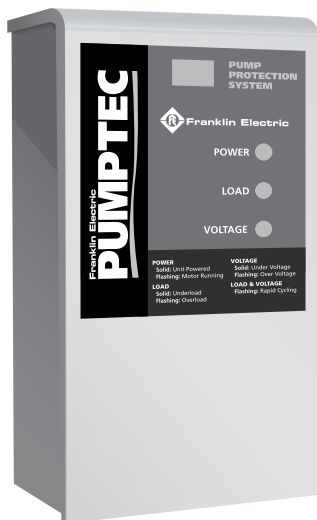

Pumptec is a microcomputer based pump protection device that continuously monitors motor load and power line conditions to provide protection against dry well conditions, waterlogged tanks, and abnormal line voltage conditions

Indicator lights provide complete system status, which can be easily viewed without removing the cover. Pumptec interrupts power to the motor whenever the motor load drops below a preset level or the load drops quickly.

Pumptec is optimized to work with Franklin 2- & 3-wire single-phase motors from 1/3 to 1.5 hp. An underload (dry well) adjustment is provided to address unusual situations.

Features

Protection Features

- Dry Well (Underload)
- Over & Under Voltage
- Rapid Cycle
- Bound Pump

Indicator Lights

- Load
- Voltage
- Status

Remote Control Features

- Over & Underload Settings
- Over & Under Voltage Settings
- Reset Time Settings
- Fault History (Last 15 Faults)
- System Status Monitor

Other Features

- Heavy Duty Relay
- 115 V/230 V 50/60 Hz Operation
- Alarm Circuit Contacts

CAUTION: This product does not replace a motor control box or the need for motor overload protection. Installation and motor overload protection should be in accordance with National Electrical Code Article 430 or in accordance with motor manufacturer's recommendations.



Franklin Electric

Technical Specifications:

Model Number	5800020611
Horsepower Rating	1/3 to 1.5
Voltage Rating	115 V/230 V
Frequency	50/60Hz
Power Consumption	4W
Response Time	3 Seconds
Reset Time	2 to 120 min. (240 min. w/remote)
Motor Type	Single-Phase Induction Run
Alarm Contact Rating	1 Amp 115 V/230 V
Over/Under Voltage Time-out	2 minutes
Operating Temperature Range	-15 °F to 130 °F

Note:

Pumptec is not designed for use on permanent split capacitor (PSC) motors.

Dry well protection occurs when pump suction is broken. Deadhead conditions may not always be detected due to variation in pump load characteristics

Installation Instructions

1. Remove the cover from the PumpteC.
2. If you will be running a 1.5 hp motor, move the circuit board jumper to the 1.5 hp position as shown in Figure 1.

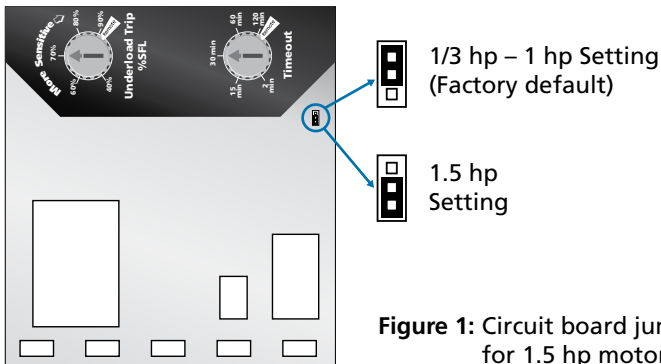

3. Mount the unit in a location convenient for wiring.
4. Turn off power at the AC source.
5. Pumptec may be wired upstream or downstream of the control switch for 2-wire and 3-wire motors. Select an installation option from Figures 2A and 2B.
6. Connect wires to the Pumptec as shown in Figure 3. Power is connected the same way regardless of the line voltage.

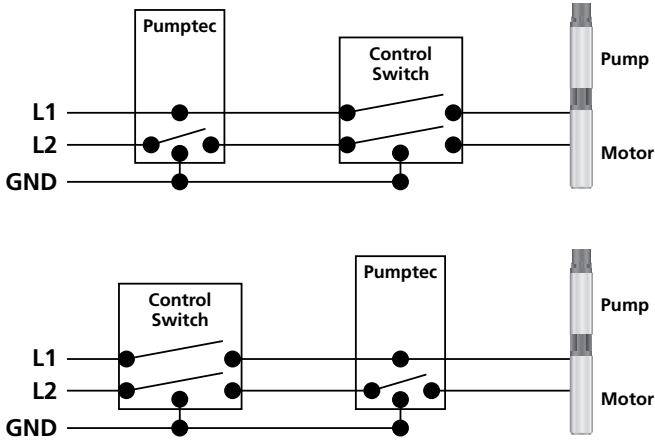

Figure 2A: 2-Wire Motor Installation Options

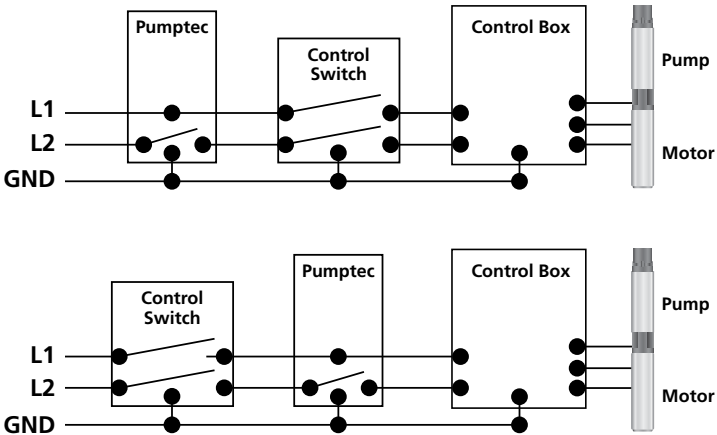
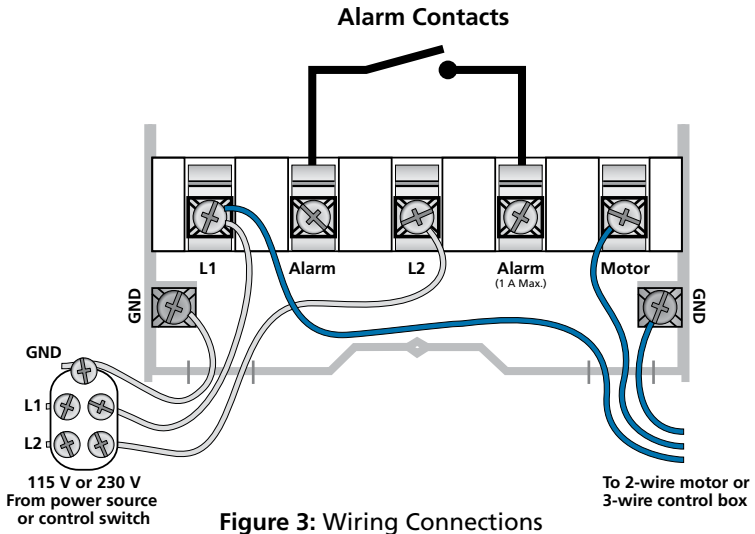
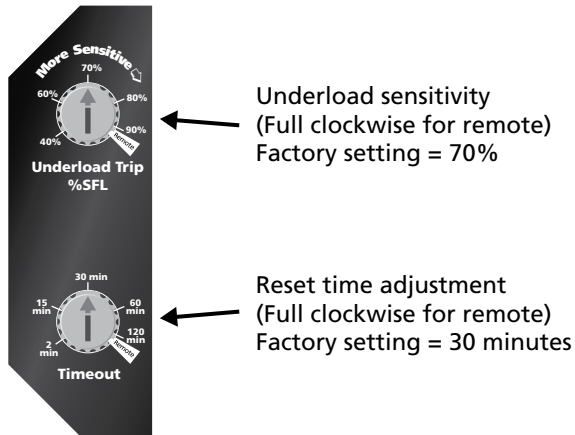

Figure 2B: 3-Wire Motor Installation Options



7. Set the time-out adjustment to the desired position. The factory setting is 30 minutes (See Figure 4)*.



8. The factory underload setting of 70% should not require any adjustment.
9. Wire in alarm circuit, if desired.

10. Replace cover and secure cover screw.

11. Turn AC power back on.

*Note: If you will be using IR remote control to set the underload and the time-out settings, set the appropriate adjustment knobs to the "Remote" position (fully clockwise position). See Figure 4. The initial remote settings are the same as the factory presets - 70% for underload and 30 minutes for the underload time-out. The underload adjustment is preset at the factory to detect underload (dry well) conditions on most systems. In general, there is no need to adjust this setting.

Operation

Pumptec has three indicator lights labeled POWER, LOAD, and VOLTAGE. If the PumpteC is connected upstream of the pressure switch, the system status can be determined from these indicator lights at any time. When wired downstream of the control switch, no status will be displayed when the control switch is open.

Power Indicator Light

If solid, the PumpteC has power and the system is idle. In this state, the motor is not running and the PumpteC is waiting for the control device (i.e. pressure switch) to close and turn on the motor.

When flashing, the system is pumping water and running normally.

Yellow Load Indicator Light

The yellow load light indicates one of three conditions:

1. A solid yellow light with no flicker indicates a dry well (underload). This is caused by the load of the motor going below the underload adjustment knob. (If you have a PumpteC remote control, this will be indicated by **underload** in the PumpteC Fault History.)
2. A solid yellow light with a slight flicker indicates an underload caused by a rapid decrease in load (approximately 25% over a twenty second period). (If you have a PumpteC remote control, this will be indicated by **underload*** in the PumpteC Fault History.)

Note: In both conditions above, the PumpteC will wait until the reset time-out period has ended before attempting to restart the motor.

3. A flashing yellow light (on for 1/2 second, off for 1/2 second) indicates an overload caused by the motor current being excessively high. The unit must be manually reset by removing power for 10 seconds. (If you have a PumpteC remote control, this will be indicated by **overload** in the PumpteC Fault History.)

Voltage Indicator Light

When the voltage light is solid, an under voltage condition has been detected. The under voltage trip is factory preset to 203 volts. The remote control feature may be used to alter the under voltage trip point.

When the voltage light is flashing, an over voltage fault has been detected. The over voltage trip is factory preset to 253 volts. The remote control feature may be used to alter the over voltage trip point.

After a voltage fault has occurred, PumpteC will check the line voltage every two minutes and will reset when the line voltage returns to the normal range.

Load & Voltage Indicator Lights Flashing

When both the load and voltage indicator lights are flashing together,

a “Rapid Cycle” condition has occurred. The Pumptec will wait the duration of the reset time-out period (either the factory preset time (30 minutes) or the time set using the underload time-out adjustment knob by the user) before attempting to restart the motor.

*Note: The “Rapid Cycle” trip criteria is 4 starts per minute. The Pumptec must be wired before the pressure switch to activate the “Rapid Cycle” feature.

Troubleshooting

Remote Control

A Pocket PC with an infrared port may be used to monitor the motor/pump system performance and adjust the Pumptec trip points. When dealing with unusual installations, the system monitor and underload adjustment remote control features allow quick diagnosis of system problems.

No Lights

No power is applied to the Pumptec. Check for voltage at the L1 and L2 connections. If Pumptec is wired downstream of the control switch, the control switch may be open.

Solid Load Light

Pumptec has detected a dry well or underload condition.

- A. Make sure the pump and motor are matched correctly.
- B. Check for a blocked pump intake or stuck check valve.
- C. The coupling between the motor & pump may be stripped.
- D. Blocked plumbing or stuck check valve may be causing a deadhead condition.
- E. The underload sensitivity knob may be adjusted in cases where the unit is too sensitive. After adjustment, check to ensure the unit is still able to detect a dry well condition.

Flashing Load Light

The system is drawing excessive current.

- A. The motor is stalled or there is a ground fault.

Solid or Flashing Voltage Light

The line voltage is too high or too low.

- A. An unloaded generator can cause a high line condition.
- B. Low line conditions can be caused by loose connections.
- C. Report persistent high or low line voltages to the power company.

Flashing Voltage & Load Lights

Rapid Cycle condition has occurred.

- A. Check for a waterlogged pressure tank.
- B. A bobbing float switch may cause rapid cycling.

TOLL-FREE HELP FROM A FRIEND

Phone Franklin's toll-free Submersible Service Hotline for answers to your installation questions. When you call, a Franklin expert will offer assistance in troubleshooting your pump protection system and provide immediate answers to your motor application questions.

**FRANKLIN ELECTRIC SUBMERSIBLE
SERVICE HOTLINE (800) 348-2420**



225468102
Rev. 0
1-14



Franklin Electric

9255 Coverdale Rd, Fort Wayne, IN 46809
Tel: 260-824-2900 Fax: 260-824-2909
www.franklin-electric.com